

# Cleaner

FOR DRAIN AND PIPE CLEANING, INSPECTION AND REHABILITATION PROFESSIONALS

www.cleaner.com | DECEMBER 2017

Brad Dutruch,  
Compliance  
EnviroSystems  
president

## CLEAN AND EVALUATE

EXPERIENCED LEADERSHIP AND  
SPECIALIZED EQUIPMENT CREATE  
A SHARP FOCUS AND HELP  
COMPLIANCE ENVIROSYSTEMS RISE  
ABOVE ITS COMPETITION **PAGE 22**

### TECH PERSPECTIVE

A step-by-step guide to vacuum tank inspection

### MONEY MACHINES

Inexpensive inspection cameras add value to jobs

### BETTER BUSINESS

Former military personnel bring skills and experience



# ***Tight Space Specialist***

## **The Power-Vee® with Power Cable Feed**

When a drain cleaning job puts you in a tight spot, using the Power-Vee is like having an extra hand to make the job easier. Just squeeze the feed lever and the cable spins into the line. Retracting the cable is just as easy.

This compact tool feeds tough Flexicore® cables at up to 16 feet per minute. Convenient quick-change cartridges make cable switching quick, clean, and easy.

It's time to upgrade from manual feed machines. Have a Power-Vee ready for your next tight spot.

It puts power in the palm of your hand.

Call the Drain Brains® at 800-245-6200 or 412-771-6300, or visit [www.drainbrain.com/powervee](http://www.drainbrain.com/powervee).

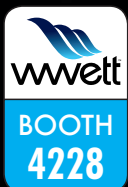

# ***General***

## ***PIPE CLEANERS***



### ***The toughest tools down the line.™***

© General Wire Spring 2017

WHEN SO MUCH IS

ON THE  
LINE

SO ARE WE.

 **BOOTH  
1061**

**Introducing One Touch Service from Vac•Con.**  
One call, one point of contact, 24/7.

While some manufacturers make the sale and become scarce, Vac•Con is staying in touch. Vac•Con's One Touch Customer Service allows you instant access around the clock, by phone or internet, to a single point of contact - a real person focused on your needs. That's right, you're never out of reach with One Touch Service from Vac•Con

**VAC-CON.COM** | **(904) 567-0225**

 **VAC•CON**  
**ONETOUCHSERVICE™**  
**MORE POWER TO KEEP YOU WORKING**

A SUBSIDIARY OF HOLDEN INDUSTRIES, INC., VAC•CON IS A 100%  
EMPLOYEE-OWNED COMPANY. ©2016 VAC•CON, ALL RIGHTS RESERVED.

# NEW



*"I used the Switcher non-stop every day, 8 hours a day, and didn't have one problem. I've been waiting for something like this."*

**JASON DEMARTINI  
VALLEJO SANITATION**



## WGR SWITCHER

For cleaning 8-36" (203-914mm) lines.

## WHR SWITCHER

For cleaning 6-18" (103-457mm) lines.

### SWITCH FROM CLEANING TO FLUSHING WITHOUT EVER LEAVING THE PIPE



Use full pulling thrust to climb inclines and go upstream to problem area.



Idle the pump down to "switch" jets to cleaning mode.



Bring the pump back to pressure to begin cleaning/cutting mode.



VIEW THE VIDEO HERE:  
[WWW.STONEAGETOOLS.COM/SWITCHER](http://WWW.STONEAGETOOLS.COM/SWITCHER)

**WARTHOG**  
SEWER NOZZLES BY **STONEAGE**®

1-866-795-1586 • [WWW.SEWERNOZZLES.COM](http://WWW.SEWERNOZZLES.COM)

Proudly Manufactured in the USA





# 1 System 3 Components Infinite Ability

The crawler system that changed sewer inspection now has even more versatility to grow with your needs. Inspect lines 4" to 108" with up to 1640' of cable, and easily add cutting-edge tech like lateral launch, laser profiling and side scanning. Enter observations, measure defects and create reports with a web-enabled touchscreen pendant. Inspect farther with the crawler platform that pioneered steerable six-wheel drive, low-resistance cable and automatic cable management.

There's plenty to consider when buying a sewer inspection crawler. Don't overlook anything; download our handy checklist at: [envirosight.com/crawler-checklist](http://envirosight.com/crawler-checklist)



## Envirosight

[www.envirosight.com](http://www.envirosight.com) • (866) 643-3191



22

## features

- 22 **Profile: Clean and Evaluate**  
Experienced leadership and specialized equipment create a sharp focus and help Compliance EnviroSystems rise above its competition.  
By Giles Lambertson
- 40 **Profile: Building on Experience**  
Nevada contractor applies the lessons learned from one successful business in modeling his own success.  
By Marian Bond



40



50

## departments

- 12 **From the Editor: A Working Resolution**  
Every day presents opportunity for positive change and business improvement.  
By Luke Laggis
- 16 **@cleaner.com**  
Be sure to check out our exclusive online content.
- 34 **Money Manager: Insuring Comfortable Retirement**  
Consider long-term care insurance as a protection against the costs of care when you get older.  
By Erik Gunn
- 50 **Money Machines: Adding Value, Not Upselling**  
Smaller, less-expensive inspection cameras reduce equipment costs and lead to pipeline repair projects.  
By Ken Wysocky
- 56 **Better Business: 7 Great Reasons to Hire a Veteran**  
Former military personnel bring skills and experience that can help build your business.  
By Dana Manciagli
- 60 **Tech Perspective: A Step-by-Step Guide to Vacuum Tank Inspection**  
Take the necessary steps to ensure your vacuum system is functioning properly and won't fail you on the job site.  
By Ronnie Tamez
- 64 **Product Focus:**  
**Business Diversification – Septic Pumping, Plumbing**  
By Craig Mandli
- 71 **Case Study:**  
**Business Diversification – Septic Pumping, Plumbing**  
By Craig Mandli
- 72 **Product News**  
Product Spotlight: Water recycling keeps sewer cleaners on the job.  
By Craig Mandli
- 74 **Industry News**

## COMING IN JANUARY 2018

### ISSUE FOCUS:

#### Manhole Inspection & Rehabilitation

**MONEY MACHINES:** Little Wizard goes where other drain machines can't

**TRAINING FOR SUCCESS:** Certifications ensure proper training and standards

**SAFETY FIRST:** Simple precautions can prevent jetting injuries



### ON THE COVER

Compliance EnviroSystems President Brad Dutruch is an industry veteran of 25 years who served a term as president of the National Association of Sewer Service Companies and is a certified trainer for pipeline assessment. The Louisiana-based company specializes in storm drain and sanitary sewer evaluation and cleaning. (Photography by Meggan Haller/Keyhole Photo)

**PERMA-LINER™  
INDUSTRIES, LLC.**



**ZERO DIG  
TRENCHLESS  
TECHNOLOGY**

# PERMA-LATERAL™ LINING

**SOLUTION**



**PROBLEM**



## TRADITIONAL DIG & REPLACE

- ✓ Backhoe and Operator
- ✓ Blacktop and Concrete Disposal
- ✓ Road Detour
- ✓ New PVC Pipe Materials to Install
- ✓ Inconvenience
- ✓ Possible Utility Service Damage
- ✓ Street Reconstruction

### **DON'T JUST REHABILITATE, SEAL THE ENTIRE SYSTEM:**

**Perma-Patch:** Lateral Spot Repair

**Pull-In-Place:** Lateral Lining System

**InnerSeal™:** Lateral to Main Connection System

**Sectional Point Repair:** Main Line Spot Repair

**Perma-Main™:** Continuous Lining, Manhole to Manhole

## PERMA-LATERAL™ LINING

- ✓ Zero Dig Technology
- ✓ Multiple installs per day
- ✓ Work Year-Round, Increased Productivity
- ✓ Ease of Use
- ✓ #1 Selling Small Diameter Pipe Relining System
- ✓ Proudly Made in the USA



**TURN-KEY TRAILERS  
& TURN-KEY BOX  
TRUCKS**

CALL TO SCHEDULE A **ONE-ON-ONE DEMONSTRATION!**



**ZERO DOWN, NO  
PAYMENTS FOR  
90-DAYS**

**100% AMERICAN MADE**

**100% TRENCHLESS**

**100% SUPPORTED**



To learn more call **1-866-336-2568** or visit **www.perma-liner.com**

# RAT OUT YOUR ROOT PROBLEMS

Root Rat nozzles are uniquely designed to make short work of big sewer line headaches – chewing up roots and encrustations in all kinds of pipe. Interchangeable heads use the chain rotor for major obstructions and the cable rotor for less aggressive problems.

Simplified service means extra uptime.



3/8", 1/2", 1" nozzles come in kit form.



Patented • Made in USA • [www.rootrat.net](http://www.rootrat.net)

SEE IT IN ACTION

Call 330.874.4300 to learn more about the nozzle you've been waiting for



## Cleaner

FOR DRAIN AND PIPE CLEANING, INSPECTION AND REHABILITATION PROFESSIONALS

Published monthly by COLE Publishing, Inc.

1720 Maple Lake Dam Rd., PO Box 220, Three Lakes, WI 54562

Call toll-free 800-257-7222 | Outside of U.S. or Canada call 715-546-3346

Mon-Fri, 7:30 a.m.-5 p.m. CST

Website: [www.cleaner.com](http://www.cleaner.com) | Email: [info@cleaner.com](mailto:info@cleaner.com) | Fax: 715-546-3786

**SUBSCRIPTION INFORMATION:** A one year (12 issue) subscription to *Cleaner* in the United States or Canada is free to qualified subscribers. A qualified subscriber is any individual or company in the United States or Canada that is involved in the inspection, cleaning, repair and installation of residential and commercial sewer lines. Non-qualified subscriptions are available at a cost of \$60 per year in the United States and Canada/Mexico. Subscriptions to all other foreign countries cost \$80 per year. To qualify, visit [www.cleaner.com/order/subscription](http://www.cleaner.com/order/subscription) or call 800-257-7222.

Our subscriber list is occasionally made available to carefully selected companies whose products or services may be of interest to you. Your privacy is important to us. If you prefer not to be a part of these lists, please contact Nicole at [nicole.labeau@colepublishing.com](mailto:nicole.labeau@colepublishing.com).

**CLASSIFIED ADVERTISING:** Submit classified ads online at [www.cleaner.com/classifieds/place\\_ad](http://www.cleaner.com/classifieds/place_ad). RATE: No Photo Classified \$25 for 20 words, each additional word \$1. All classified advertising must be PAID IN ADVANCE. DEADLINE: Classifieds must be received by the first of the month for insertion in the next month's edition. PHONE-IN ADS ARE NOT ACCEPTED. Ads may be faxed only when charging to MasterCard, VISA, Amex or Discover. Please supply all credit card information with faxed ads. Be sure to include your phone number (with area code) in your ad. Make checks payable to COLE Publishing Inc. and mail with classified ad to the address above. CLASSIFIED ADVERTISING APPEARS NATIONWIDE AND ON THE INTERNET. Not responsible for errors beyond first insertion.

**DISPLAY ADVERTISING:** Contact one of our sales staff at 800-994-7990. Publisher reserves the right to reject advertising which in its opinion is misleading, unfair or incompatible with the character of the publication.



Kayla Bisnette Jim Koshuta

**REPRINTS AND BACK ISSUES:** Visit [www.cleaner.com](http://www.cleaner.com) for options and pricing. To order reprints, call Jeff Lane at 800-257-7222 (715-546-3346) or email [jeff.lane@colepublishing.com](mailto:jeff.lane@colepublishing.com). To order back issues, call Nicole at 800-257-7222 (715-546-3346) or email [nicole.labeau@colepublishing.com](mailto:nicole.labeau@colepublishing.com).

**CIRCULATION:** Circulation averages 25,642 copies per month. This figure includes both U.S. and international distribution.

© 2017 COLE Publishing Inc.

No part may be reproduced without permission of the publisher.

GET SOCIAL WITH Cleaner



[www.facebook.com/CleanerMag](http://www.facebook.com/CleanerMag)



[www.twitter.com/CleanerMagazine](http://www.twitter.com/CleanerMagazine)



[www.youtube.com/CleanerMagazine](http://www.youtube.com/CleanerMagazine)



[www.linkedin.com/company/cleaner-magazine](http://www.linkedin.com/company/cleaner-magazine)



WATER & WASTEWATER EQUIPMENT, TREATMENT & TRANSPORT SHOW

FEBRUARY 21-24, 2018

Indiana Convention Center, Indianapolis, Indiana

[www.wwettshow.com](http://www.wwettshow.com)

Beyond buckets and blades.

digDIFFERENT

FIND OUT HOW.

FREE subscription at [digdifferent.com](http://digdifferent.com)



Season's Greetings with all good wishes for the New Year.



YOUR FRIENDS AT COLE PUBLISHING



# Jetstream®

Subsidiary of Federal Signal Corporation

Surveying the landscape, Jetstream tools were built to withstand everyday applications. Let us help you find your waterblasting unit, pump and parts and accessories through Jetstream, our 12 US FS Solutions rental centers or the 8 JJE Canadian locations.

Remember with Jetstream tools... **JUST ADD WATER.**

## Any Pressure... We've Got Your Tools.

**J-FORCE™**



15,000 psi / 22,000 psi

**MagJet™**



40,000 psi

**Jetstream®**  
Subsidiary of Federal Signal Corporation

©2017 Jetstream of Houston, LLC. All Rights Reserved. Jetstream®, J-Force™ and MagJet™ are trademarks of Federal Signal Corporation.

**A**

A Corp/Rooter-Man ..... 14

**ALLAN J. COLEMAN**  
SINCE 1905

Allan J. Coleman Co. .... 17, 61

Arctic Blasters, Inc. .... 14

**C**

Cable Center, The ..... 48, 75

 CAM  
Cam Spray ..... 38

 CENTRAL OKLAHOMA  
**Winnelson**  
Central Oklahoma Winnelson ..... 35

 **CIPP**  
Robotics LLC  
CIPP Robotics LLC ..... 32

 TORQUE MASTER  
THE PROFESSIONALS CHOICE  
Coast Manufacturing ..... 63

 CUES  
CUES ..... 27

**D**

 **DRAINABLES**  
direct  
Drainables Direct ..... 29

 **DURACABLE**  
Duracable Manufacturing Co. .... 39

**E**

 **Electric Eel**  
Electric Eel Mfg. .... 18

 **Envirosight**  
Envirosight, LLC ..... 5

 **enz** usa inc.  
Enz USA, Inc. .... 36

**F**

 **Solutions**  
F. S. Solutions ..... 37, 69, 71, 73

Forbest Products Co. .... 13

Formadrain, Inc. .... 20

**G**

 **GapVax**  
GapVax, Inc. .... 83

 **General**  
PIPE CLEANERS  
General Pipe Cleaners ..... 2

GI Industries, Inc. .... 25

 Gorlitz Sewer & Drain, Inc. .... 11

 **GUZZLER**  
Guzzler Manufacturing ..... 19

**H**

 HammerHead Trenchless ..... 45

Hurco Technologies, Inc. .... 52

**I**

I.S.T. Services, Inc. .... 12

**J**

 **Jetstream**  
Jetstream of Houston ..... 9

Jetters Northwest ..... 62

**K**

 **Ken-Way**  
Ken-Way Corporation ..... 74

**L**

 **Lansas**  
Lansas Products ..... 42-43

LaPlace Equipment Co. .... 35

**M**

 **MAXLINER**  
MaxLiner USA ..... 31

 **MRP**  
Milwaukee Rubber Products, Inc. .... 20

 **MONGOOSE**  
JETTERS  
Mongoose Letters by Sewer Equipment ..... 59

 **MyTana**  
MyTana Mfg. Company, Inc. .... 33

**N**

 **NLB Corp.**  
NLB Corp. .... 49

 **NozzTeq**  
NozzTeq, Inc. .... 57

**P**

 **PERMA-LINER**  
INDUSTRIES, LLC  
Perma-Liner Industries, LLC ..... 7

Petersen Products Co. .... 74

 **PICOTE**  
Picote Solutions ..... 48

**Q**

Quik-Lining Systems, Inc. .... 38

**R**

 **RS** Technical Services Inc.  
R.S. Technical Services, Inc. .... 21

 **RapidView**  
IBAK  
RapidView IBAK North America ..... 51

 **Ratech**  
ELECTRONICS  
Ratech Electronics, Ltd. .... 30

 **ROOT RAT**  
NOZZLES  
Root Rat ..... 8

**S**

 **SCOOTER**  
Scooter Video ..... 55

Sewer Equipment of Nevada ..... 38

Shamrock Pipe Tools, Inc. .... 63

 **SPARTAN**  
Spartan Tool, LLC ..... 84

 **STONEAGE**  
StoneAge, Inc. .... 4

 **SUPERIOR DRAIN CABLE**  
MFG. & SUPPLIES INC.  
Superior Drain Cable Mfg. & Supplies ..... 32

**T**

 **T&T TOOLS**  
T&T Tools, Inc. .... 54

 **TRIO-VISION**  
Trio Vision LLC ..... 47

Trojan Worldwide, Inc. .... 14

TST Sweden AB ..... 57

**U**

 **ultraSHORE**  
PRODUCTS  
Ultra Shore ..... 32

USB USA LLC ..... 58

**V**

 **VAC-CON**  
Vac-Con, Inc. .... 3

 **VAR**  
CO  
VARCo ..... 30

 **VIVAX**  
METROTECH  
Vivax-Metrotech Corp. .... 58

**W**

 **WATER**  
CANNON  
Water Cannon, Inc. - MWBE ..... 82

Westmoor Ltd. .... 18

 **WinCan**  
WinCan, LLC ..... 36

Wohler USA, Inc. .... 63

WWETT Show ..... 15, 53, 70, 81

**Z**

Zip Drain ..... 54

Marketplace ..... 76-77

Classifieds ..... 78-80

Have you seen the  
**Cleaner**  
E-Zine?



Go to **cleaner.com**  
to view the e-zine.

**Cleaner** It's FREE! Subscribe online at [www.cleaner.com](http://www.cleaner.com)



# GORLITZ SEWER & DRAIN INC.

Norwalk Blvd. Santa Fe Springs, Ca. 90670

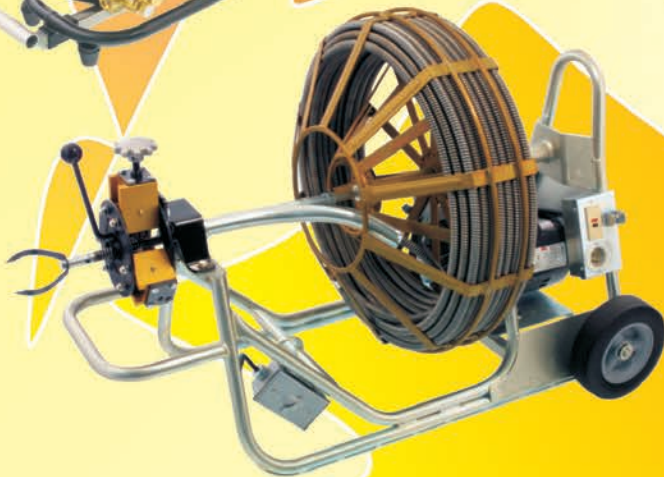
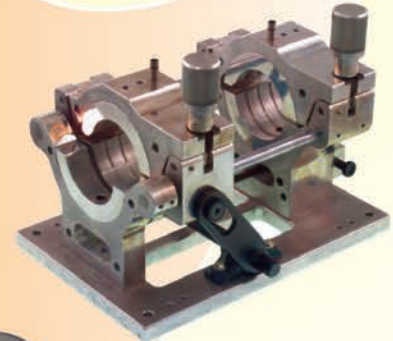

- MACHINES**
- FEEDERS**
- CABLES**
- RAMPS**
- CONNECTORS**
- LEADERS**
- CHUCKS**
- ENDS**
- RETRIEVERS**
- SPLICES**
- AUGERS**
- JETTERS**
- NOZZLES**
- HOSES**
- TRENCHLESS PIPE SYSTEMS**
- SOCKET FUSION KITS**

*Engineering, Dedication, Quality, Sales and Service All In One Stop!*

www.gorlitz.com  
 Email: sales@gorlitz.com  
 f GORLITZ on Facebook



Tel: (562) 944-3060  
 Fax: (562) 944-7630



Luke Laggis  
editor@cleaner.com

# A Working Resolution

Every day presents opportunity for positive change and business improvement

By Luke Laggis

**W**ell, 2017 is almost in the books — another year down, and another one ahead.

When I was a kid, Christmas and New Year's both seemed like such a big deal. I remember going to my grandma's every Christmas Eve. Opening presents at home the next day. On New Year's Eve, I'd play hockey with my buddies on the old outdoor rink. We had a key to the warming house and the lights, and it felt like we were celebrating in the greatest way possible, at least for 12-year-olds.

It doesn't mean so much now because I don't see any one day as more important than another. They're all important. We get 365 of them every year, and the really important thing is what we do with the total of that time.

I think resolutions are garbage. If I feel it's important to make a change in my life, I'm sure as hell not waiting until January rolls around. That's a waste of every day that comes before it, a waste of time that could be spent improving whatever it is that needs improving.

It's the same in your business. It's great to take stock of your successes and failures over the past year and think about how you're going to make the next year better. It's even better to act on things now. Resolutions are idealistic. Taking steps to improve your business is pragmatic.

I'm probably not saying anything you haven't thought before, but sometimes it's good to hear it from someone else. You're probably not going to die tomorrow, but you could, so why put anything off? Planning leads to plans. Action leads to improvement.

So what do you need to do to make your business better? What changes can you make to put your goals within reach? More importantly, what can you start doing today to make that happen?

I just returned from WEFTEC, the Water Environment Federation's Technical Exposition and Conference. It's always good to catch up with others in the industry and find out what's going on outside my own little bubble. I came away with some new perspectives and ideas for 2018, but I'm not waiting for December to fall off the calendar before I start working on them.

One of the nice things about being in the publishing world is I'm constantly presented with opportunities to improve on what I've just done. Once a month, the slate is wiped clean. Every print cycle sort of begins my own little New Year.

You essentially have the same opportunity on a daily basis. Every job is an opportunity to improve on your work and better serve your customers. If you're serious about improving your business, you need to take that mentality to every job because each one presents opportunity beyond a simple drain cleaning or inspection. If you run into difficulties or make a mistake relining a lateral, you can't wait until next year to make it right for the customer. Likewise, you shouldn't wait for next year to make things right for your business.

Every day presents opportunity for improvement. Don't waste it. Enjoy this month's issue. **C**

**Stunning and enduring results!**

**ELASTOTEC COATING SYSTEM**  
Coating with ELASTOTEC increases the lifespan of pipes - with high resistance to pressure and chemicals

ElastoTec injection casting pump with spray/brush application

Coating: ≥ 3 mm

- » Easy to use and transport
- » Repairs 1.5 to 8 inch diameter pipes
- » No wasted material or reinstatements
- » 2 part polyurethane resin

**DURABLE NEW SURFACES IN PIPES**  
- Especially smaller diameters

For more information call (858) 997-0004 or email: info@istamerica.com

## WHY BUY FORBEST

- Our products are the easiest devices to use and record with both USB and SD cards;
- Our products are reliable and the most affordable;
- We offer the lowest service cost and the shortest turn-around.

### Smart Crawler Inspection System

FB215

**NEW**

- Suitable for pipe with diameter from 6" - 16"
- Creeping speed: 20'-66' per min
- 6-wheels drive
- Double motors can turn left and right
- Waterproof level: IP68
- Pan Tilt 360°/180° color camera head
- 500' Cable & Reel w/Meter Counter
- 10" LCD Control Station w/USB & SD recording
- Typing and Editing

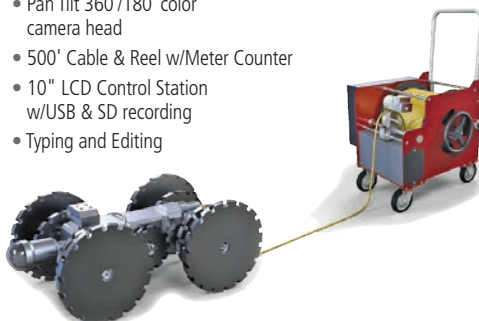

### Portable Layflat Camera System

FB-3188X/4188X

- 7"/10" Color Control Station w/USB & SD Recording
- 1" Metal Waterproof Color Camera Head
- Option: 1" Self Leveling Color Camera Head w/ or w/o Built in 512HZ Sonde Transmitter
- 5.2mm 130FT/ 6mm 200FT Cable & Layflat Reel



**NEW**

### Portable Color Sewer/Drain Camera

FB-PIC3188SD



Starting At: \$550

- 65'/100'/130' Cable & Reel
- 1" Metal Waterproof Color Camera Head
- 12 High LED Lights w/Sapphire Glass
- 7" LCD Monitor w/USB & SD

### Multi Frequency Locator

FB-R2013E

- 3.5" LCD Display with backlight
- Frequency: 512, 1K, 2K, 8K, 33K, 65K, 83KHZ
- High Precision of Depth and currency Measurement
- Built-in GPS, generate the pipeline drawing automatically
- With "A" frame for anti-corrosion coating inspection
- Working depth: 20'
- Built-in 7.4V Li-ion battery
- Built in memory



**NEW**

### Portable Electric Drain Rooter

FB-EDR6002

- Excellent for Small Line Cleaning in lavatory, sink, tub or shower drains
- Input power: 300W
- Max Speed: 550RPM
- Cord: .25" diameter; 25' long
- N.W.: 3.9kg



**NEW**

### Mid/Long Range Pipe Inspection Camera

FB-PIC3388MT/3288T/3488T



- 200'/300'/400' Cable & Reel w/Meter Counter
- Self Levelling Camera Head
- Spring Kit w/Built in 512HZ Sonde Transmitter
- 10" LCD Monitor w/USB&SD

### Pan-Tilt 360°/180° Camera System

FB-PIC3688A/3688AT

- 200'/ 400' Cable & Reel w/Meter Counter
- Pan-Tilt 360°/180° Color Waterproof Camera Head w/Manual Zooming
- Spring Kit w/512HZ Sonde Transmitter for 3688AT
- 10" LCD Monitor w/DVR & MIC
- Recording with USB Flash Drive & SD Card
- Crawler for easier push
- Typing & Editing (Optional)
- Control Panel Integrated in the Heavy Duty Waterproof Case



**NEW**

### Chimney Camera

FB-3688C/3388C

- 130'/200' Cable & Reel
- Pan-Tilt 360°/180° Waterproof Color Camera Head w/Manual Zooming/ 1 1/2" Self-Leveling Camera Head for option
- 10" LCD Multi-function Control Station w/ USB & SD & Typing



**NEW**

The Trojan

# C100-512SL

has it all

**Introductory Price**  
**\$1995**

LED Light Adjustment knob

SD Card Recording with USB Adapter

Built-in Microphone for Voice Recording

Built-in Battery (7 hour life)  
Includes A/C Adapter for Charging and Direct Power

Built-in Foot Counter

115' of Durable Push Rod

7" LCD with DVR

Protective Visor

Operates Horizontally or Vertically on Collapsible Stand

Includes 2 Skids

Built-in 512 Hz Transmitter

1" Self-Leveling Waterproof Color Camera Head with Adjustable LED Lights

Works in 1-1/2" - 4" Lines



**TROJAN**  
WORLDWIDE INC.



**ORDER NOW**

**800-392-4902**

3306-C Ella Blvd, Houston, TX 77018  
[www.trojanworldwide.com](http://www.trojanworldwide.com)

Join A National Brand  
**ROOTERMAN.COM**

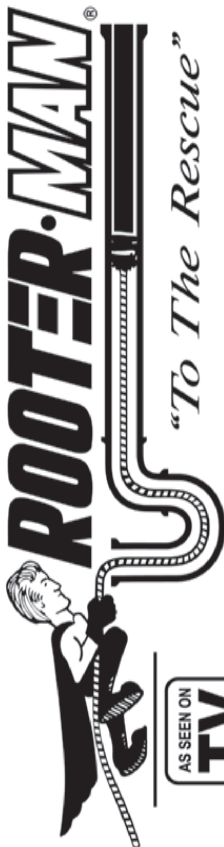

AS SEEN ON TV

Without Paying the National Brand Price

**NEW CONCEPT: NO ROYALTY ON PERCENTAGE OF SALES**

**Reserve Your Exclusive Territory**

**Call 1-800-700-8062**

**FRANCHISE PACKAGE \$3,975.**

SEE THE VIDEO AT: [WWW.ARCTICBLASTER.COM](http://WWW.ARCTICBLASTER.COM)

IT JUST MIGHT BE THE BEST  
TOOL YOU'LL BUY THIS WINTER!!



Perfect for Public Works, Plumbers, Rentals, Etc.

Thawing: Frozen water lines • Sewer lines • Valve and load lines • Culverts

**A PROPANE TORCH,  
2 GALLONS OF WATER AND  
THE AMAZING  
ARCTIC BLASTER**



THAT'S ALL YOU NEED TO SEE FAST, SAFE  
AND ECONOMICAL THAWING RESULTS.

The Arctic Blaster will have the job done before most thawing devices are ready to work.

Perfect for Public Works - fits behind the wheel well in your pickup truck, makes steam  
in 10 minutes or less and will thaw 30 ft of water line in 15 minutes.

**ARCTIC BLASTER BOX 918 SUNDRE, AB TOM 1X0 403-638-3934**



## ENTIRE COMMUNITIES COUNT ON YOUR SYSTEM SUPPORT

But where do you find support - find the tools you need to manage and grow your business?

WWETT Show 2018 is the industry event to gather and talk shop with your peers. To see live demos of the latest tools and equipment. To take classes to enhance your skills and fulfill your CEUs. You will come away stronger and better equipped to take on future opportunities and to overcome obstacles. Make your plans now to be a part of WWETT Show 2018.

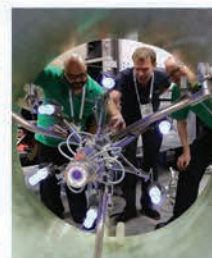

**wwett<sup>™</sup>18**

EDUCATION: FEBRUARY 21-23

EXHIBITS: FEBRUARY 22-24

INDIANA CONVENTION CENTER

### WHY SHOULD YOU ATTEND?

- ✓ **Explore the Marketplace** for tools and resources you need for your business
- ✓ **Education** taught by some of the best and brightest in the industry
- ✓ **Events** to network with your peers - or just kick back with friends.

# @Cleaner.com

Visit the site daily for new, exclusive content. Read our blogs, find resources and get the most out of *Cleaner* magazine.

## HIRING ADVICE

### 3 Key Traits of a Good Pipe Lining Technician

Lining pipe properly is not an easy job and a great lining technician could be considered more of an artist than a technician. Unfortunately, pipe lining is not yet taught at any school, so finding a person who's knowledgeable about it is difficult unless they have already had industry experience. But there are still a few fundamental characteristics you can keep an eye out for that can tell you someone is destined to be a proficient pipe lining technician. >> [cleaner.com/featured](http://cleaner.com/featured)



## OVERHEARD ONLINE

“The World Wide Web is exactly that: a connected web of information. Now, imagine that Google is the spider, crawling around to check on everything. If you're not optimized, you're a loose strand of web that doesn't look relevant, even if you run a successful business.”

— Optimize Your Website to Get More Leads and Long-Term Returns  
>> [cleaner.com/featured](http://cleaner.com/featured)

## PRODUCTIVITY TIPS

### Take Advantage of a Slow Business Day

You may dread the times when the phone isn't ringing, but a slow business day doesn't have to be an unproductive one. It can be an opportunity to play catch-up on long neglected tasks and make plans to ward off future slow periods. One business owner gives her advice on how you can tackle such a situation. >> [cleaner.com/featured](http://cleaner.com/featured)



## HURRICANE HELP

### Contractors Step Up in the Wake of Harvey and Irma

When Hurricanes Harvey and Irma struck the United States in late August and early September, many contractors were ready to immediately provide aid, such as Minnesota's Davids Hydro Vac. Owner Michael Morehouse, a Houston native with family still in the area, made the long trip to Texas to help out in the wake of Harvey. Read his story at [Cleaner.com](http://Cleaner.com) as well as the stories of Landshark Hydro-Excavation in Texas, and Murphy Pipeline Contractors in Florida. >> [cleaner.com/featured](http://cleaner.com/featured)



## Emails and Alerts

Visit [Cleaner.com](http://Cleaner.com) and sign up for newsletters and alerts. Get exclusive content delivered right to your inbox and you'll stay in the loop on topics important to you!

Join the Discussion



Facebook at [facebook.com/CleanerMag](https://facebook.com/CleanerMag)



Twitter at [twitter.com/CleanerMagazine](https://twitter.com/CleanerMagazine)



# ALLAN J. COLEMAN

SINCE 1905

**Call us today!**  
**773-728-2400**

5725 North Ravenswood Avenue • Chicago, IL 60660 • [info@allanjcoleman.com](mailto:info@allanjcoleman.com) • [www.allanjcoleman.com](http://www.allanjcoleman.com)

**OLDEST NAME IN THE BUSINESS — Over 100 YEARS OLD**

**RIDGID**

## CS6x)) Digital Recording Monitor With Wi-Fi



- Wi-Fi and Bluetooth
- Direct-to-USB recording for fast, efficient documentation of inspection jobs
- Water-resistant keypad for direct control of essential camera and monitor functions
- Daylight viewable display for a crisp, clear in-pipe image
- SeeSnake HQ Software to edit, archive, and deliver reports via print, DVD, or online
- On-screen keyboard for basic titling and text entry
- CS6 will dock in the RM-200 Max or operate as a stand alone monitor

## CS65x)) Digital Reporting Monitor With Wi-Fi



- Wi-Fi and Bluetooth
- Storage Options: Internal Drive & USB Ports
- Internal GPS
- Water-resistant Keyboard
- Daylight Viewable Display

## SeeSnake® Mini Camera Reel



- 1 1/2" to 6" Lines up to 200'
- New Self-Leveling Camera Head
- Built-In 512 Hz Sonde
- Metal Frame and Rugged Drum

## SR-24 Line Locator with Bluetooth® and GPS



- Omnidirectional antennas
- Large display • Built-In GPS
- Bluetooth® technology
- Smartphone/Tablet App
- Can trace any frequency from 10 Hz to 35,000 Hz



## NaviTrack® Scout®

Scout is designed to solve demanding remote transmitter (sonde) locates using multi-directional locating technology.

## CS12X Monitor

- Large High Resolution 12.1" display
- Dual Battery Power – two batteries can be installed for maximum runtime
- Capture images and video directly to a USB drive
- Stream or Record to an iOS or Android phone or tablet



## SeekTech® SR-20

SeekTech uses omni-directional antennas, guidance arrows and an easy to read mapping display.

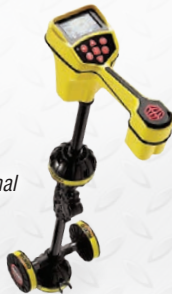

## MR-10 Magnetic Locator

- Quickly locate buried iron or steel objects
- Ergonomic rugged design includes carrying case and batteries
- Highly sensitive instrument with audio and visual feedback
- AutoNull feature blocks out nearby metallic interference such as an automobile or chain link fences



**Authorized SeeSnake Repair Center**

**THE BEST SERVICE AND FAST TURN AROUND!**

**We Have RIDGID Parts!**

**If you buy the best, you are only sorry once!**



# CAM ace 2™

- » One-touch USB recording
- » 5.4" LCD monitor
- » 200' of Kevlar braided ½" dia. push cable
- » 1.68" dia. color camera
- » 512 Hz Sonde
- » On-screen footage counter
- » Wheel kit for easy transport and maneuverability
- » Reel brake
- » Centering skid

*Electric Eel*®

www.electriceel.com  
Toll-Free: 1.800.833.1212

*Made in the USA*



# ProVac

## Industrial Pumpout System

*Happy Holidays and Season's Greetings  
from  
Westmoor Ltd.*

 BOOTH 5134

[www.westmoorltd.com](http://www.westmoorltd.com)

  
Vacuum Technology

**800-367-0972**



# Industrial Strength

When you clean industrial plants for a living, you need a vacuum truck that's as tough as you are. That keeps going, day after decade. That's backed by people who get that your livelihood depends on your truck staying productive. With Guzzler®, you get more than the toughest industrial vac truck in the business. You also get the strength of a team ready to deliver support, parts, service, training, consulting and industry expertise. A team dedicated to helping you expand your business by exploring new markets and applications for your Guzzler truck. That's industrial strength.

For a demo, or to meet your Guzzler team, call 800-627-3171 or visit [www.guzzler.com](http://www.guzzler.com).





## “Is this the “perfect” lateral lining & spot repair system?”

Many installers tell us it is...here’s why:

It’s proven for lining laterals and spot repairs since 1994:

- It’s practically indestructible, cures 5 times stronger than industry standards!
- There’s no felt tubes, we use epoxy and woven fiberglass!
- There’s no measuring for transitions!
- There’s 100% no digging—we use existing cleanout. Always!

Because it’s pulled or pushed into place, you can place the epoxy liner *exactly* where you want it. Perfect for spot repairs!

- **Lining T’s, Y’s and Offset Joints:** Tees, Ys and offset joints, are no problem and it doesn’t matter whether you’re doing a 4” to 6” transition or have an offset joint...
- **Exceptional Customer Support:** Includes fully training your people on the ground and support from 8:00am to 8:00pm by engineers...
- **Incredible Strength:** The woven fiberglass and steam-cured epoxy is very strong, predicted to last 50 years or more...
- **Quality Product:** The finished product is amazingly uniform!

See for yourself! Get your free info kit and see our videos:



Brought to you by  
Formadrain, Inc.  
**LATERAL LINING**  
PERFECTED™

Download your **FREE Info Kit!**  
at [www.Laterals.work](http://www.Laterals.work)

email [bruce@formadrain.com](mailto:bruce@formadrain.com),  
(888) 783-7415

# WINTER JACKET SALE



**\$49.95\***

### 75-1301 Yellow

PU coated, polyester lined, fully taped seams & a zip-out liner. Waterproof. Detachable hood, elastic ribbed waist & cuffs with inside & outside pockets.

Sizes M - 6XL.

### CSJC-306OR Orange

PU coated, polyester lined, fully taped seams & a zip-out liner. Waterproof. Detachable hood, elastic ribbed waist & cuffs with inside & outside pockets.

Sizes M - 5XL. **\$49.95\***



### 75-1381 Yellow

Eight wearing options including a CL3 zip-out liner or CL2 vest. Jacket & liner have removable sleeves. Six pockets, fleece collar, detachable hood, radio handset straps, ID pocket badge holder & many more features. Waterproof.

Sizes M - 6XL. **\$69.95\***



\*Tall sizes available on some styles for an additional \$6.

Jackets meet ANSI/ISEA 107-2010 CL3 standard.



Call Toll-Free  
**1.800.325.3730**

# JOIN

THE CONVERSATION.  
THE CAMARADERIE.  
THE COMMUNITY.

## Cleaner

- f facebook.com/CleanerMag
- t twitter.com/CleanerMagazine
- y youtube.com/CleanerMagazine
- in linkedin.com/company/cleaner-magazine

# THE TOP 5 REASONS PROS CHOOSE RST PIPELINE INSPECTION VEHICLES

## #1 Ergonomic Designs

The layouts of our high cubes, Sprinter and Transit vans along with our trailers reflect deep industry experience. We've thought long and hard about the little things that make a big difference for equipment operators.

## #2 Super Durable Components

While our CCTV cameras have a well-earned 30-year reputation for performance and durability, RST complements these productivity tools with extreme-duty cable reels with self-aligning sealed bearings, aircraft-grade aluminum framing, ultra-durable plastics and more.

## #3 Smart Workspaces

We could save time and money using only off-the-shelf cabinetry, but custom building tool bins, counter tops, and workstations translate to better fits, more room, and better work flows.



## #4 Single Conductor Technology

RST's CCTV equipment utilizes Single Conductor Technology, which offers multi-function flexibility, great video quality, and power through a nearly indestructible steel-wrapped cable. We back up our cable with an industry-leading 5-year warranty.



### NEW: Advanced Manhole Inspection System

The new RST Helix surveys a typical manhole in under a minute. It can be deployed from a van, ATV, pick up, or tripod.



## #5 Budget-Friendly Configurations

Whether you need a sewer, stormwater, or custom set up, count on us to work with you to put together a productivity package that fits your budget.

**LEARN MORE FAST OR REQUEST A DEMO**

(800) 767-1974 [RSTechserv.com](http://RSTechserv.com)

# RS Technical Services Inc.

High Performance Pipeline Inspection Systems

Demonstrations/Sales: 800.767.1974 • [www.rstechserv.com](http://www.rstechserv.com)

# CLEAN AND EVALUATE

EXPERIENCED LEADERSHIP AND SPECIALIZED EQUIPMENT CREATE A SHARP FOCUS AND HELP COMPLIANCE ENVIROSYSTEMS RISE ABOVE ITS COMPETITION

BY GILES LAMBERTSON  
PHOTOGRAPHY BY MEGGAN HALLER/KEYHOLE PHOTO



**ABOVE** Donald Browder (left) and Dalrone Kinchin of Compliance EnviroSystems use an easement machine running off a Vac-Con combination truck to jet a sewer line in Baton Rouge, Louisiana.

**<<** Water flows back into a manhole while Chris Hooker (out of frame) jets a sewer line.

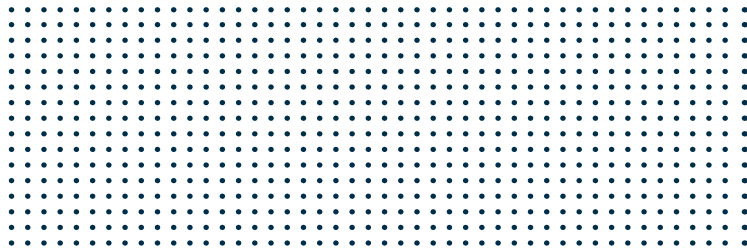



Compliance EnviroSystems – commonly referred to as CES – is a Louisiana storm drain and sanitary sewer evaluation and cleaning company, yet it has more projects outside the state than inside. It calls itself a comprehensive company, but it isn't interested in expanding beyond its core mission. These contradictory identities are resolved in one word: data.

“We are one of the few companies I know of that stay in our lane,” says David Guillory, CES vice president of business development. “We are strictly an evaluation and data company. We might look like a construction company, with excavators on pontoons, but we’re not a construction or engineering firm. We don’t make repairs. All we are doing is evaluating and providing data.”

This focus on providing comprehensive feedback to clients is accomplished by fielding technicians for such diverse tasks as high-pressure cleaning of lines; CCTV inspection; sonar, dye, and smoke testing; and locating cross bores, just to name a few services. The results of these field operations are recorded,



profile

## COMPLIANCE ENVIROSYSTEMS

BATON ROUGE, LOUISIANA

PRESIDENT: Brad Dutruch

ESTABLISHED: 1995

EMPLOYEES: 100

SERVICES: Sewer cleaning, inspection and assessment

CUSTOMER BASE: Municipal storm and wastewater utilities

WEBSITE: [www.ces-sses.com](http://www.ces-sses.com)



The Compliance EnviroSystems team includes (front, from left) Clayton Sharp, Weston Rachal, Stephen Lacombe, Lloyd Bumgarden, David Guillory, Brad Dutruch, Chris Hooker, Kevin Quatrevingt, Donald Browder and Kellie Latchie; Back: Justin Ayers, Dalrone Kinchen, Johnathin Achord, Victor Hall Jr., Marc Fogos, Lionell Sellers Jr., Steven Jackson, Quincy Gallien, Brandon Lee and Kieran Bridges.

tabulated in the CES data management center as needed, and otherwise jelled into useful information for clients.

“Specialization” is another term that helps define CES. Numerous clean-and-evaluate companies operate in areas where CES is active, but few are as well-equipped. “I would like to say there is competition in certain areas but not many others can take on the kinds of jobs we take on,” Guillory says. “We are very specialized.”

An example is an unusual pipe cleaning job in New Orleans. The pipe runs through a levee and is accessed from beneath a bridge. To reach it, equipment has to be floated. This is no problem because CES has a cleaning rig mounted on a pontoon boat as well as a tracked cleaning rig that can both float and crawl. Both pieces of equipment were custom fabricated. The company also uses two Marsh Master amphibious vehicles and three larger soft-track vehicles to reach places inaccessible to jet/vac trucks.

Its more conventional rolling stock includes 23 trucks — representing a mix of manufacturers — dedicated to cleaning operations and CCTV inspections. It even has an airborne fleet, sort of — three drones, the first one purchased in 2015. “A lot of the drone footage is for internal use, for helping us plan a job,” Guillory says. “In places that are hard to reach, we can send a drone over it and come back to the office and determine from its footage what pieces of equipment will be needed on a project.”

Specialized equipment separates CES from most competitors. The rest of the company’s edge comes from its expertise and, well, its steely resolve. “When municipalities are looking for ideas on how to evaluate a system, they come to us and ask, ‘How do we do this job?’ Even more important, once we get out into the field, we can run into so many kinds of problems, and that’s where we really separate ourselves from the competition,” Guillory says. “We never leave a job. Even if it turns out to be harder and more expensive than we planned, we never leave a job. Our reputation is on the line.”

### EFFECTIVE LEADERSHIP

The company’s impressive reputation is mirrored in the brass at the top. Company President Brad Dutruch is an industry veteran of 25 years — since his high school days. “Brad sort of handpicked a team from across the country, people with a lot of experience, and oversaw the collection of equipment we need to do this kind of work,” Guillory says.

Along the way, Dutruch served a term as president of the National Association of Sewer Service Companies and is a certified trainer for pipeline assessment. One number summarizes his experience: 40 million. That’s how many linear feet of sanitary sewer pipe he’s helped evaluate. Over all, the company estimates it has cleaned 70 million feet of pipe since its incorporation in 1995.





**"I WOULD LIKE TO SAY THERE IS COMPETITION IN CERTAIN AREAS BUT NOT MANY OTHERS CAN TAKE ON THE KINDS OF JOBS WE TAKE ON. WE ARE VERY SPECIALIZED."**

David Guillory

<< Lionell Sellers Jr. lowers a RapidView CCTV camera into the line at the start of a sewer inspection.

**BELOW** Victor Hall Jr. moves an easement machine into position near an off-road manhole to clean a segment of sewer line.



# HEAVY-DUTY PIPE and SEWER CLEANING

**NEW**  
**MERLIN**  
 Complete Package for  
**\$6,821.15**  
 See the details at  
[www.giind.com](http://www.giind.com)

- Variable speed from 0 to 1,750 rpm
- Forward/Neutral and Reverse Rotation
- Cutting/Cleaning Grinding, Re-instating
- Cleans up to 150 ft.
- Built-in Air/Water Flush
- ID from 1/2" to 2 ft.
- Runs on 110/220 volt

- Contractor's Package**  
 Part Number - TCM-5001
- 1 TCM-5000 Drilling/Reaming Machine w/cart
  - 1 Flexible Shaft 100' (FS501)
  - 1 Flexible Shaft 50'
  - 1 4" Pipe Cutter
  - 1 4" Flex Hone 40 grit abrasive
  - 1 Expandable Flex Hone 2'-3"
  - 1 Shaft Lubricator
  - 4 Lubricating Fluid 8oz.
  - 1 Repair Crimping Block
  - 4 Tool Repair Coupling
  - 4 Drive Repair Coupling
- Package \$6,821.15**



GI Industries Inc. • 800-724-1944 • [www.giind.com](http://www.giind.com) • [sales@giind.com](mailto:sales@giind.com)  
 Owned/Operated and Made in the U.S.A.

The firm's vice president, Joshua Hardy, has pretty impressive numbers as well. During his 20 years at the company, Hardy has managed sewer evaluations totaling 10 million linear feet, overseen 100 flow studies, and recommended rehab procedures for 2 million linear feet of pipe. He also is a professional engineer, as is Guillory, whose expertise is management. Guillory is a former director of the Department of Public Works for the city of Baton Rouge, where he managed 800 employees and negotiated and oversaw a \$1.4 billion consent decree project to rehabilitate and enlarge the city's system.



**ABOVE** Justin Ayers performs a CCTV inspection of a sewer line in Baton Rouge.

**BELOW** GIS coordinator Tyler Robinson works on mapping.

Not all CES expertise is at the top. The company's 100 employees include veterans of the industry like project manager Tim Jacobs. After 32 years in the industry, Jacobs has supervised diving jobs and river basin cleaning projects, handled floating rigs and countless other pieces of equipment, and managed numerous routine cleaning projects. Jacobs has just about done it all, according to Guillory.

**"WE NEVER LEAVE A JOB. EVEN IF IT TURNS OUT TO BE HARDER AND MORE EXPENSIVE THAN WE PLANNED, WE NEVER LEAVE A JOB. OUR REPUTATION IS ON THE LINE."**

David Guillory

Jacobs is currently responsible for a sewer assessment and rehabilitation program in Memphis, Tennessee. CES technicians there are in the fifth year of an 8- to 10-year project, partnering with the city and with the global engineering firm Black & Veatch. More than 1 million feet have been evaluated, but there is plenty of work remaining. The system contains almost 3 million feet of pipe that's 18 inches in diameter or smaller and another 385,000 feet of interceptor pipe ranging from 2 to 8 feet in diameter.

### **BUILDING PARTNERSHIPS**

In its work with cities, Compliance EnviroSystems often works directly for an engineering firm that has contracted with the city, which is the case in Memphis. Whereas in one of the company's landmark jobs — a 10-year project in Atlanta created by a consent decree — the company worked more or less directly with city officials.

A third partnership model is evident in DeKalb County, Georgia, where CES interacts about equally with public officials and the consulting engineering company overseeing the project. "I think it depends on the resources a city has," Guillory says. "Small cities a lot of times will lean on engineering firms to help them navigate the paperwork of a project."



Guillory says it's difficult to quantify how much each line of service contributes to the overall bottom line. He notes that evaluation and cleaning projects are often paired, with one preceding the other, though not always. The company's ability to scour large-diameter pipes brings many cleaning-only jobs. In terms of evaluation services, standard CCTV inspections are most often requested, but CES technicians are also kept busy with high-definition TV examinations, dyeing of lateral joints, and cheap and quick smoke testing.

CONTINUED >>

# GO THE DISTANCE

with the CUES Compact Pipe Ranger



Lightweight, compact, and rugged steerable TV camera transporter



Traverse long distances and tough pipe conditions found in sanitary and storm sewers



Multiple wheel sets to maximize bottom-clearance, traction, and optimize camera position



Compact design for entry into small inverts, small manholes, dead end lines, and traversal of sweeps

SINGLE-POINT WHEEL REMOVAL



"The Standard of the Industry"



Call today and deal directly with the product specialists at CUES!

[www.cuesinc.com](http://www.cuesinc.com)  
800.327.7791  
[salesinfo@cuesinc.com](mailto:salesinfo@cuesinc.com)



Lionell Sellers Jr. prepares to lower a CCTV camera into a sewer line in Baton Rouge. Compliance EnviroSystems is a full-service professional sanitary sewer and storm drain evaluation provider.

Cross-bore inspections make up another growing sector of work for the company. The cross bores typically result from a natural gas company boring a path for a new gas line and completing the project without realizing that the head of its boring unit passed through a drainline or sanitary sewer line. Laterally launched gas pipes follow the bore hole through the drainpipes.

“That creates a dangerous situation,” Guillory says. “If there is gas leakage, it can migrate into a sewer line and eventually from there into homes. The potential for an explosion is real, and that’s when the gas company becomes liable.”

This scenario has brought CES a different client base — private utility companies that own and manage the underground assets and are looking for these legacy cross-bore problems. CES already is working with utility clients in Texas, Mississippi and Georgia. “Companies are saying, let’s find and fix these cross bores and not put people at risk.”

## PUSHING BOUNDARIES

In 2005, hurricane recovery was the focus of the company’s work. Louisiana was struck by two major storms that year — Katrina in August and Rita a month later. Consequently, for the remainder of that year and some time thereafter, the company found all the work it could handle at its doorstep. Its crews helped with cleanup operations in numerous coastal locations as well as inland where communities struggled to restore their systems.

In addition, CES was contracted to manage restorative efforts in New Orleans. It oversaw a 100-truck, high-pressure fleet representing several contractors that cleaned, vacuumed, inspected and evaluated battered storm drains and sanitary sewer systems.

Yet in 2017, the company is not as Louisiana-centric as it was a dozen years ago. There are as many projects under way in Alabama and southeastern



## featured equipment

**Black & Veatch**  
913/458-2000  
www.bv.com

**RapidView IBAK North America**  
800/656-4225  
www.rapidview.com  
(See ad page 51)

**Vac-Con, Inc.**  
904/284-4200  
www.vac-con.com  
(See ad page 3)

states as there are in Louisiana, not to mention three projects in Puerto Rico and a cleaning and evaluation job in the Pacific Ocean in Hawaii. CES looks more like a regional company now, with fingers reaching way offshore.

Guillory says circumstance, not a planned expansion, has the company working far from home.

“We go where the work is. We were created and are based in Baton Rouge, and over the years, we’ve mostly been in Louisiana. At the moment, it just happens that more than half of our projects are out-of-state, but that could change in the next 12 months.” **C**

# CLEANING UP AFTER HURRICANE KATRINA

When Hurricane Katrina struck New Orleans and areas north of the city in August 2005, it wreaked havoc on the infrastructure of the populated areas ... and spawned opportunity for companies like Compliance EnviroSystems. The reality was that a 10-year-old sewer and drain cleaning company that was still establishing itself in the industry suddenly had a mess outside its door that begged to be cleaned up.

“Yes, I would say the Katrina effect was a turning point in our company history,” says David Guillory, CES vice president. The company subsequently was tapped to oversee some major cleanup in New Orleans and surrounding areas. It quickly geared up to supervise that work — as well as perform individual contracts — and never looked back.

The company cleaned 58,000 catch basins in New Orleans and 3 1/2 million linear feet of storm drainpipe. When Hurricane Rita made landfall the next month, CES technicians cleaned storm drains in adjacent St. Bernard and Jefferson parishes.

Guillory says heavily flooded areas in New Orleans produced a tragic windfall of clogged storm drains. The streets themselves were clogged as well, with cars tumbled over by wind and water and trailers that floated into lanes of traffic. “Getting to a storm drain access point was half the battle. It was just a workout. Our job started before we ever got to the inlets.”

At least a thousand people died during Katrina, according to federal officials. “But thankfully, we didn’t find any bodies during our work,” Guillory says. “We came in after the floodwaters had receded, though they were still doing search and recovery in the areas where we were working. Our crews did see search personnel recovering people and animals from nearby houses, but thankfully, we weren’t in the houses.”

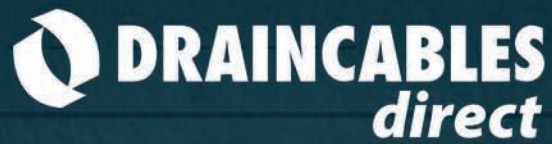

# WANTED

## CABLES THAT DELIVER REAL REWARD

With Draincables Direct cables, don't worry about picking 'em out of a line [UP.] Get products that will stand the test of time, and provide your business with the most reward.



SEE THE FULL LINEUP AT [DRAINABLES.COM](http://DRAINABLES.COM)  
OR CALL OUR SALES TEAM AT 800.421.4580

# More choices, more solutions, more innovation. That's Ratech.

- ✓ One-Touch USB recorder or SD recorder
- ✓ 10.4" sunlight-readable LCD
- ✓ Built-in Lithium Ion battery
- ✓ Wi-Fi connectivity-record direct to smartphone or tablet
- ✓ 100'-400' Premium Gel Rod™ Push cable
- ✓ 1.375" dia. Self-leveling camera
- ✓ Keyboard, footage counter, 512Hz sonde
- ✓ 3/4" micro camera compatible
- ✓ Pan n' Tilt push camera compatible
- ✓ Authorized service centers nation-wide



Video Pipeline Inspection Systems



Pan n' Tilt Push Camera (Includes Reel and Remote Control)



Control unit can be mounted to reel.

For more information on these or other products call toll free: 1-800-461-9200 or 905-660-7072 [www.ratech-electronics.com](http://www.ratech-electronics.com)

Upload your inspection videos to [YouTube](https://www.youtube.com) Ask us HOW?

MANUFACTURING SEWER CAMERAS SINCE 1981.



ORDER TOLL FREE  
866-872-1224

SHOP 24 HOURS A DAY 7 DAYS A WEEK  
ONLINE AT [WWW.VARCOPIUMPER.COM](http://WWW.VARCOPIUMPER.COM)



## VARCO LATERAL LINE/WATER JETTER HOSE

VARCO Branded and MADE IN THE USA;

We get it for cheaper, so we can sell it for cheaper.

- Lateral line hose has become the standard for the septic industry.
- Polyether-urethane cover provides exceptional cut, abrasion and fungus resistance.
- Sizes from 1/8" up to 1", Working pressures up to 4800psi.

### PREMIUM PIRANHA SEWER HOSE

	DESCRIPTION	500 ft	600 ft
3/4"	Premium Pirhana Orange 2500psi	\$1,095.00	\$1,314.00
1"	Premium Pirhana Orange 2500psi	\$1,285.00	\$1,540.00
3/4"	Premium Pirhana Blue 3000psi	\$1,154.00	\$1,385.00
1"	Premium Pirhana Blue 3000psi	\$1,485.00	\$1,780.00



NEW  
VARCO  
JETTERFLEX  
HOSE

PREMIUM  
PIRANHA  
SEWER HOSE



Comes on Plastic Reel- For No Extra Charge! No Cardboard to Get Wet! Smaller sizes and lengths do not come on reel - check with your customer service rep for details.



### NEW VARCO JETTERFLEX LATERAL LINE / JETTER HOSE

4000 psi rated • Safety Green - Pressure Tested • Precoupled assemblies MXM pipe thread fittings

**\*3/16" ON CLOSEOUT SPECIAL - SAVE 25%**

	50'	75'	100'	150'	200'	250'	300'	400'	500'	600'
1/8"	\$15.28	\$21.25	\$26.38	\$37.49	\$48.60	\$56.74	\$66.88	\$87.15	\$107.45	-
3/16"	\$21.23	\$26.95	\$33.60	\$44.89	\$56.84	\$68.80	\$80.75	\$104.66	\$128.58	\$152.50
1/4"	\$29.85	-	\$55.85	\$81.82	\$107.77	\$126.38	\$150.52	\$198.77	\$247.02	\$295.28
3/8"	\$62.08	\$91.28	\$105.54	\$151.12	\$215.06	\$259.57	\$304.05	\$382.09	\$469.43	\$556.77
1/2"	-	-	\$186.69	-	\$353.97	-	\$518.17	\$660.02	\$853.29	\$972.66

SOURCE KEY  
12C17



# ONLY THE BEST HAVE THIS MUCH ENDURANCE.

MaxLiner's portable, lightweight and quality-assured CIPP equipment gives you the ability to climb to the top. Our expertly made custom liners, high-performing resins, unrivaled in-the-field training and customer support come together for what endures: Cured-in-Place lateral and vertical pipes that accommodate diameter changes, easily negotiate bends, resist unwanted longitudinal stretch and stay strong for decades. [MaxLinerUSA.com](http://MaxLinerUSA.com)



T 877.426.5948



Equipment sales  
Rentals  
Service



Authorized dealer & service partner for IMS products

# EQUIPMENT FOR RENT

## NANO

DN 3" - 4"



## DRIVE

DN 6" - 16"



## MICRO

DN 3" - 10"



## TURBO

DN 8" - 32"



## CLEANER

DN 4" - 20"



## UV Equipment

DN 6" - 60"

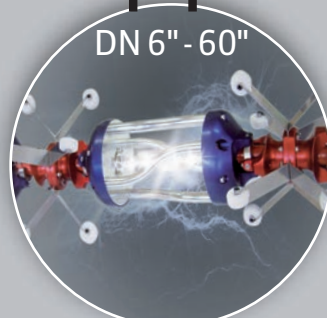

320 Raccuglia Dr. • La Salle, IL 61301

Phone: 815 - 220 - 1919 • Fax: 815 - 220 - 1918

[www.cipp-robotics.com](http://www.cipp-robotics.com)



## SUPERIOR DRAIN CABLE

MFG. & SUPPLIES, INC.



MFG. & SUPPLIES INC.

66 Otis Street, Unit B  
West Babylon, NY 11704

GO TO OUR WEBSITE AND GET

**10 %** off

USE A PROMO CODE  
SAVING

**FREE**

AIR FOOT PEDAL  
OR  
2" ALUMINUM BLADE HOLDER  
WITH \$ 100 PURCHASE  
1ST TIME BUYER

Toll Free: 855-643-0900  
Tel: 631-643-6100

[WWW.SUPERIORDRAINABLE.COM](http://WWW.SUPERIORDRAINABLE.COM)

Electric Eel General RIDGID Spartan

ultra ultra ultra  
**LIGHT - VERSATILE - SAFE**

**ultraSHORE**  
P R O D U C T S



Quick to Install.  
As light as 130lbs.



Roll Your Own.  
Optional wheel kit.



Stacks easily with  
2' & 4' high panels.

*This is What Aluminum Shoring Was Meant to be!*



1-800-683-8837

**1-800-SHORING**

CALL TOLL-FREE NATIONWIDE • 1-800-746-7464

[www.shoring.com](http://www.shoring.com)



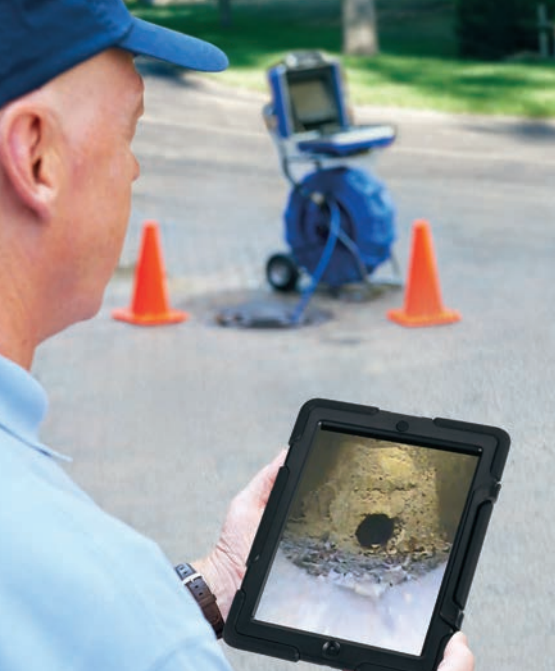

**Be ready for whatever the day brings your way.**

***Our Contractors Package fills your truck with everything you'll need for work on 1 1/4" - 10" lines.***

Lease options available.

*We have answers, advice and solutions.*

*Products are IN STOCK and ship factory direct to you.*

*We've got your back.*

**MyTana**

*"How can we help you?"*

PROUDLY SERVING YOU FOR **60 YEARS** 1957 - 2017

Help is always at your fingertips at **www.MyTana.com** and **1-866-948-7576**



# Insuring Comfortable Retirement



Erik Gunn is a magazine writer and editor in Racine, Wisconsin. Direct Money Manager inquiries to [editor@cleaner.com](mailto:editor@cleaner.com).

Consider long-term care insurance as a protection against the costs of care when you get older

By Erik Gunn

**M**ost of us think about a long period of retirement in good health. But, we know that all the kale in the world doesn't guarantee good health forever. Someday it will be harder to do the ordinary things and we won't feel so great; someday our spouse might need help. How do we pay for help, nursing care or physical therapy?

Enter long-term care insurance, or LTCI, a policy that will pay for all kinds of care over the long haul, whether you're in your own home, an assisted living facility or a nursing home.

"But wait!" you're thinking. "Doesn't Medicare pay my medical bills after I'm 65?"

Medicare does pay for hospital and nursing home stays (Part A); doctor visits, lab tests, medical equipment and such (Part B); and at least some medications (Part D).

Medicare will also pay for rehabilitation in a rehab facility or nursing home but only after a hospital admission and only for 90 days. It may cover some physical or occupational therapy at home, but those circumstances are limited.

## DO YOU HAVE HELP?

Most importantly, Medicare doesn't cover assistance with activities of daily living: dressing, bathing, toileting, walking, continence and eating.

You might think, "Well, we'll live at home, and we can help each other. Someone can come in a couple of days a week." That might work if your kids live nearby, or you live in a very connected community and know your neighbors (and your neighbors' kids!) well, or if you wind up in a big-city apartment building with friends a couple doors away.

But kids move away for jobs. Neighbors change. Or maybe you don't really want your friends to know you quite that well.

LTCI can pay for a home health aide to come in every day. If one of you gets a neurological disease like Alzheimer's or Parkinson's, LTCI can take a lot of the sting out of the bills at a continuing care facility, where the sicker spouse can have nursing care when needed, help with medications, and therapy, while the other spouse won't have to be a constant caregiver.

## CHOOSING A PLAN

So how do you go about buying a LTCI policy?

As with any insurance, the further you are away from needing the payout, the lower the premiums. Buying LTCI when you're young and healthy is cheaper. Insurance companies can't raise premiums for life events (like a diagnosis of early-onset Alzheimer's), but the premiums will certainly go up a little bit every year, and you can expect a bigger bump at certain age bands, much like life insurance policies.

The policy should spell out the premiums over time. You can also purchase guaranteed level-premium insurance: the initial cost will be higher, but the premium will remain the same for a given period (again, the younger you are, the lower the premiums and the longer they stay low).

About half the states in the U.S. have standards for premium setting; make sure you understand what your state mandates, if anything.

There are varying limits of coverage for varying premiums — more of a payout, higher premiums. All policies will have some kind of waiting period (known as the elimination period) before coverage is available, and the longer the waiting period, the lower the cost. (Think 30 days, 45 days, 90 days. Although, of course, this varies.)

## MORE OPTIONS

Some companies will offer options to purchase more coverage over time — you might start out with minimal coverage for a low premium and gradually increase both your premium and your coverage. Ask what the purchase options are: Sometimes if you turn down the option a couple of times, that option is foreclosed.

You may want to consider a combination of life insurance and LTCI, especially if you are young and healthy. Pay a given premium for, say, 30 years, and at a particular age, the benefit amount becomes payable for long-term care instead of death.

Most companies offer inflation protection — a 2 to 3 percent annual boost in the payout. "Simple" protection means that the boost is based on the original amount available. Especially if you're older, you probably want "compound" protection — meaning that the increase is applied to the currently available payout.

Talk through any exclusions with the agent offering the policy. Be sure common problems like heart disease and diabetes aren't excluded, and by all means, get coverage for illnesses that usually mean a long period of gradual deterioration, like ALS or Alzheimer's.

Watch out for definitions that are too rigid: Dementia care should be covered regardless of the cause, which often can't be diagnosed until after death.

## CHECK THE STANDARDS

Ask how payment works if one of you needs some care, gets better and then needs care again — do you have to satisfy the elimination period again? (The answer should be "no." Look for "elimination period: once per lifetime" in the policy.)

Typically, companies will offer a discount to couples buying policies to cover both spouses. Ask if you're buying one policy that covers two people or

# YOUR SOURCE FOR RIDGID®



**CS6x Digital Recording Monitor**  
with Wi-Fi



**LT1000 Laptop Interface System**



**SeeSnake® Compact 2 Camera Reel**



**CS65x Digital Reporting Monitor**  
with Wi-Fi



**DVPak**



**SeeSnake® MAX rM200 Camera System**



**microDrain Reel**

**CALL TOLL FREE: 888-947-8761**

5037 NW 10th  
Oklahoma City, OK 73127

**www.centralwinnelson.com**

CENTRAL OKLAHOMA  
**Winnelson**  
COMPANY

**8% ONE YEAR FINANCING AVAILABLE!**  
Longer lease rates also available. Call Keith for details.

**BUYING A SEESNAKE?**

**CALL US FOR  
GREAT PRICING &  
FREE SHIPPING!**

**WE  
WILL NOT BE  
UNDERSOLD**

**- Call Evenings and Weekends -**

**Keith: 405-602-9155**

two policies, one for each of you. Ask what happens to the benefits when one spouse dies — can the other spouse pick up the coverage?

The insurance commissioner in your state will have minimum standards for LTCI offered in your state; the policy should say upfront that it complies with those standards, but remember, those are minimums.

Shop around! If your spouse is employed outside your business, they may have access to a policy through their job or a professional association.

### EXPERIENCE MATTERS

The longer a company has been writing LTCI, the more likely it is that they have better actuarial models and offer realistic premiums in light of payouts they have had to make. Check the company's website for its history. And check with your state's insurance commissioner to see who is licensed in your state and look for complaints; check with the rating companies (Moody's, Standard & Poor's, and A.M. Best) for the company's rating.

Above all, take your time to understand this topic. AARP is a great source of information ([www.aarp.org](http://www.aarp.org)) and so is your state's insurance commissioner.

A certified financial planner (a fee-based, not commission-based, planner) can also help, particularly in understanding the relationship among Social Security, Medicare, any investments you have, and insurance. The National Association of Professional Financial Advisors ([www.napfa.org](http://www.napfa.org)) has a state-based directory.

LTCI is like all insurance: You hope you'll never need it, but if you do, you're best off if you get it long before that time comes.

If you're approaching retirement now and haven't looked into it, don't waste time. And if retirement is the furthest thing from your mind, it's never too soon to at least investigate your options.

If nothing else, think of it as one more guarantee for a little peace of mind in your later years. **C**

**LaPlace  
Equipment  
Company**

**CALL 985.652.5210**

FOR YOUR WATERBLAST PROJECT SOLUTIONS  
**WWW.H2OBLAST.COM**

**RENTAL, SALES  
& SERVICE**

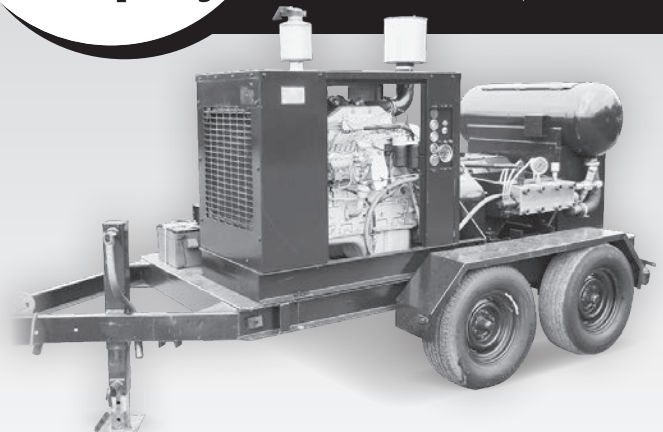

**UNITS FOR SALE:**

**JETSTREAM 3620**

- CUMMINS "B" ENGINE
- THEROTICAL 20K @ 12.9GPM
- TRAILER MOUNTED WITH DAY TANK

**JETSTREAM 4220**

- 20K @ 20GPM
- B/W T-300**
- 10K @ 16GPM

## Turn Sewer Data Into Insight.

With more data about sewer condition coming from an expanding array of technologies, depend on WinCan to gain critical insights, share them easily online, and make maintenance and rehab decisions that maximize ROI.

 **WinCan**  
 (877) 626-8386  
[www.wincan.com](http://www.wincan.com)

  
**BOOTH  
 6132**

## The Ultimate Plumber's Helper! enz® ALL-IN-ONE Water Jetting Kit

Everything you need for safe, more efficient pipe cleaning vs. "old school" mechanical rodding

- Safer on all types of pipes sized 1-1/2" – 6" dia.
- Includes right nozzle for any type of tough blockage – grease, mineral deposits, roots



*Micro Rotator Vibration Nozzle for removing grease deposits, lime and urine scale in smaller residential pipes*



CALL 1 877 ENZUSA1  
 For a dealer near you  
[www.enzusainc.com](http://www.enzusainc.com)

**enz®**  **usa inc.**

1585 Beverly Ct., Unit 115 | Aurora, IL 60502

# HIGH PRODUCTIVITY TOOLS

## FOR THE TOUGHEST WATERBLASTING JOBS



*Tube Cleaning*

*Surface Preparation*

*Pipe Cleaning*

# NEED THE POWER OF HIGH PRESSURE WATER HARNESSED TO PERFECTION?

Jetstream®, is your waterblast superstore with units, pumps, parts, accessories and hands-free tools that are productive, easy to use and loaded with operator safety features. Jetstream parts and accessories are conveniently available for rent or purchase at Jetstream as well as 12 FS Solutions locations throughout the U.S. and 8 JJEI locations in Canada.



*J-Force Series*

*Tube Spinners*



*Orbi-Jet™ X22*

***Call to learn more about Jetstreamlining your business!***

fssolutionsgroup.com • 800-822-8785 | waterblast.com • 800-231-8192 | jjei.com • 800-263-1262



**Joe Johnson Equipment**  
Subsidiary of Federal Signal Corporation

© 2017 Federal Signal. Jetstream® and FS Solutions® are registered trademarks of Federal Signal.



## 2017 Trailer Jet Prices Offered For Your Year End Planning!

**We Custom Build Machines To Your Specifications!**



800-648-5011  
www.camspray.com

\*Prices Shown Are Good Through December 31st, 2017 | Van and Truck Mount Models Available See All The Features And Specifications At Camspray.com

### STB Series Trailer-Mounted Drain Jets



- DC-Powered Jet Hose Reel and 4-Nozzle Set
- Pressure Gauge & Hour Meter
- Electric Start with Low Oil Shutdown
- Pumps Handle Fluids Up To 160°
- Lockable Tool and Storage Boxes
- 150' Garden Hose on Manual Reel
- 300 Gal Tank with Low Water Shut Off
- Gearbox Drive Triplex Plunger Pump with Ceramic Plungers and Stainless Valves
- Trailer with Industrial Painted Finish and 15" Aluminum Wheels

**STB4012K \$18,999**  
• 12 G.P.M. @ 4000 PSI  
• 999 CC Kohler • 400' x 1/2" Hose

**STB3015K \$18,999**  
• 15 G.P.M. @ 3000 PSI  
• 999 CC Kohler • 400' x 1/2" Hose

**STB2712K \$13,499**  
• 11.5 G.P.M. @ 2700 PSI  
• 689 CC Honda • 400' x 1/2" Hose

**STB3708K \$13,299**  
• 8 G.P.M. @ 3700 PSI  
• 689 CC Honda • 300' x 3/8" Hose

**STB4007K \$13,299**  
• 7 G.P.M. @ 4000 PSI  
• 689 CC Honda • 300' x 3/8" Hose



**TT4018DT-350 \$33,499**

• 18 Gallons Per Minute  
• 4000 PSI

- 66 Horsepower Kubota 4-Cylinder Liquid Cooled Diesel Engine
- 25 Gal Fuel Tank Gives Hours of Run Time on a Single Fill
- 350 Gal Tank with 2" Hydrant Fill
- Heavily Constructed Trailer With 2" x 4" Steel Tube Box Frame
- Air Purge Valve, 25 Gal Anti-Freeze Tank and Freeze Protection
- Hydraulic Powered Reel with 500' x 1/2" Hose and Variable Speed Control
- 4 Nozzle Kit Storage Box with Accessories

**MORE?!**

More Stories at [Cleaner.com/featured](http://Cleaner.com/featured)

**Cleaner** See what's not in print!



GAS ENGINE PORTABLE JETTERS PRICES STARTING AT \$2,599



ELECTRIC MINI JETTERS PRICES STARTING AT \$1,199

made in the • AMERICAN MADE  
USA • Fast Shipping  
• Call Us For A Quote

**(702) 527-5100**

LIVE TECH SUPPORT • PARTS & ACCESSORIES AVAILABLE FOR ALL EQUIPMENT  
WWW.SEWEREQUIPMENTCOMPANYOFNEVADA.NET

**WE DIAGNOSE & SERVICE ALL BRANDS**

## Sewer Equipment Company of Nevada

CAMERA & LOCATOR COMBO

STARTING AT \$1,899  
3 YEAR WARRANTY



SEWER CAMERA & LOCATOR PACKAGES AVAILABLE 3 YEAR WARRANTY



WWW.SEWEREQUIPMENTCOMPANYOFNEVADA.NET

Your TRUSTED Lateral Lining Manufacturer!

## Drain, Waste & Vent Rehabilitation



Quik Coating Systems is pleased to announce their **NEW AIPP** (Applied In Place Pipe) rehabilitation system for DWV piping.

- » 1 1/2" through 4" pipe
- » Fully structural repair
- » Resin applications cure in 15 to 20 seconds
- » Applied in layers to required thickness
- » Reusable hoses and brushes
- » No licensing fees

CONTACT US FOR MORE INFORMATION // 605-695-6778

**Quik-Lining Systems**

WWW.QUIKLINING.COM  
E-MAIL // JOHN@QUIKLINING.COM

DURACABLE DALE



WORDS OF WISDOM

QUALITY MATERIALS.

RIGOROUS TESTING.

**BEST CABLE**

ON THE MARKET.



**YOU CAN COUNT ON DURACABLE**

TO GET YOU THE RIGHT PRODUCTS, RECOMMEND A SOLUTION OR TALK YOU THROUGH A TIGHT SPOT.

FROM RELIABLE DRAIN CARE TO QUALITY-TESTED & WARRANTY-BACKED MACHINES AND CABLES,

**WE'VE GOT YOUR BACK.**

**BUILT USA TOUGH**

**10% OFF**  
MACHINES



**20% OFF**  
CABLES



**30% OFF**  
DRAIN CARE

VALID DECEMBER 6 - 22, 2017. PROMO 572. NOT VALID ON DM140, PC4, PC5, OR ROOTX. NOT VALID WITH OTHER OFFERS OR ON PREVIOUS ORDERS. SUBJECT TO CREDIT APPROVAL.

DURACABLE.COM



DURACABLE  
— MANUFACTURING CO —

877.244.0556

RIGHT IN THERE WITH YOU.



The Absolute Drain team includes (from left) Ian Castonguay, Jacob Green, Bobby Reedholm, Beth Castonguay, owners Laura and Mickey Castonguay, Tawney Kline and Mickey Castonguay II.



# BUILDING ON EXPERIENCE

NEVADA CONTRACTOR APPLIES THE LESSONS LEARNED FROM ONE SUCCESSFUL BUSINESS IN MODELING HIS OWN SUCCESS

BY MARIAN BOND

PHOTOGRAPHY BY TOM R. SMEDES

**T**he real estate market in the Reno, Nevada, area has been growing, and with it, the demand for presale plumbing and sewer inspections. Absolute Drain Service has tapped into that demand, and it's been good for business.

Mickey Castonguay, owner of Absolute Drain Service, had nine years' experience as a technician with Affordable Drain Service in San Diego when he moved to Reno in 2004. He initially worked with a relative in general construction, but he was eager to put his experience and training with Affordable Drain Service to work.

He opened his company in 2006, offering cleaning and inspection services to local plumbers who didn't offer those services themselves.

## BUILDING A BASE

Armed with cameras and a new US Jetting 4018 trailer jetter, he made a list of every plumber in the area and sent out a fax promoting his drain cleaning and inspection. He followed up with a phone call, emphasizing that he would not be in competition for plumbing and repair work; he just wanted to clean and inspect drains.

Through these efforts he was able to connect with a prominent local firm, Precision Plumbing & Heating. The company's owner was soon recommending Absolute Drain Service to others in the area.

He was already off to a good start when another lucrative plum dropped into his lap. A local real estate agent heard about the company and inquired about presale sewer inspections, which were becoming an increasingly important element of real estate transactions. With the Reno-Sparks area in a growth phase, the real estate market provided a valuable opportunity.

The company now does about 15 to 20 percent of its business with real estate agents. Plumbing companies make up the largest portion of the business base at about 60 percent, with the rest coming from the commercial and municipal sector along with some direct residential service.

**"WHEN I STARTED THIS COMPANY, I FOLLOWED THE SAME BUSINESS MODEL I HAD SEEN SUCCEED WITH AFFORDABLE DRAIN SERVICE. NO REPAIRS. WORK FOR PLUMBERS. RELY ON WORD-OF-MOUTH. NO ADVERTISING. OFFER SET PRICING."**

Mickey Castonguay



**ABOVE & >>>** Absolute Drain owner Mickey Castonguay uses a RIDGID NaviTrack locator to trace the path of a sewer lateral outside a customer's home.

profile

## ABSOLUTE DRAIN SERVICE

RENO, NEVADA, SERVING NORTHERN NEVADA

**OWNER:** Mickey Castonguay

**FOUNDED:** 2006

**EMPLOYEES:** Six

**SERVICES:** Drain cleaning, inspection, CCTV, jetting, leachfield cleaning

**CUSTOMER BASE:** Plumbing companies, real estate agents, commercial, municipality

**WEBSITE:** [www.absolutedrainservice.com](http://www.absolutedrainservice.com)

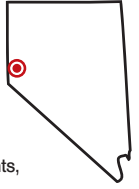

## Lansas<sup>®</sup> PRODUCTS

Manufactured by Vanderlans & Sons, Inc.



### MANHOLE VACUUM TESTING

Lansas has a full line of vacuum testing components and kits available.

21" - 27" Multi-Size Vacuum Test Head and Super Vac™.



### "SMART BOX™" LINE ACCEPTANCE TEST KIT

From plugs to panels we manufacture all components needed for line acceptance and leak locating.



### JOINT TESTER

We have joint testers available in single and double bladder designs for pipe sizes 24" - 144". These units are available in high and low pressure models for use in pipe lines which allow up to 5% deflection.

### SST PLUGS

Single Size Test Plug (SST) with smart air test triple hose.



“When I started this company, I followed the same business model I had seen succeed with Affordable Drain Service,” Castonguay says. “No repairs. Work for plumbers. Rely on word-of-mouth. No advertising. Offer set pricing.”

For the Reno-Sparks area, which is about a 10-mile radius, the rates start at \$69 for a simple drain issue, \$89 for the next step up, and then \$125 if they need to go in through the roof. A camera inspection ranges from \$175 to \$200. Jetting is \$300 to \$350. There is an added fee for traveling outside the immediate area.

Billing practices with the plumbing companies can go both ways: sometimes Absolute Drain Service will bill the plumber, other times the customer. But regardless, the rate remains stable. When the client is a real estate agent, the bill will go to the homebuyer or seller, depending on the situation. Once again, he sticks with the standard prices as long as they are within the local market.

When there is something in the system that requires repair, Castonguay has several firms he can recommend to come in and do the work. This includes relining and pipe bursting, along with excavation if required. Typically, he will suggest three firms to select from.

>> Mickey Castonguay and his son Mickey II set up for a lateral inspection at a house in Sparks, Nevada.



## CUSTOM JOINT TESTER

This joint tester was designed and built for a water project near Phoenix, Arizona.

Each joint of this 21' diameter pipeline was tested at 32 PSI.

*Custom Designs  
Are Always™ Available*

**VANDERLANS AND SONS, INC.**

California 1-800-452-4902

Atlanta 1-770-509-9309

Chicago 1-800-452-4902

Houston 1-832-831-4458

[www.lansas.com](http://www.lansas.com)





## HOUSING BONUS

Working within the real estate community has become a pleasant and rewarding part of the business for Castonguay.

“I really had not thought about finding business within the real estate community,” he says. “But I really like being a part of it. I particularly find the agents to be extremely organized and knowledgeable, and they want to take care of their clients. Currently, I have about 150 customers in that category.”

After the initial business came his way, he began promoting his services by stopping at real estate offices and putting his red business cards in the real estate agents’ mail slots.

“I did that for a lot of years, and the agents would refer me to others in the business,” he says. “This has become a regular inspection for these transactions. People have to be aware of the liability if there are problems. I actually do a lot of the real estate inspections myself because I like doing that.”

“This business may pick up because of the renewed interest in Reno and the various business entities moving here and drawing national attention. We need to accommodate the real estate market. The agents want to make their clients happy. We do whatever it takes.”

Through the real estate connection, another avenue for growth developed with cleaning and jetting septic system leachfields. There are several regions with septic systems within the two cities and broader area they serve.

## BUILDING A STABLE BUSINESS

Absolute Drain Service has seen impressive growth in a short period of time — going from a one-man operation in 2006, through the financial crisis, to the current status with four technicians on the road.

“Our biggest challenge in the beginning was the lack of money,” says owner Mickey Castonguay. “What I did have was the equipment — cameras and a jetter and locator, plus the training and the determination to make this a viable company for myself and my family.”

During that initial struggle while he made payments on equipment, his wife, Laura, held outside employment to pay the bills, but with the stability they now enjoy, she works in the office along with her sister-in-law Tawny Kline. The women split responsibilities on a part-time basis.

Castonguay is currently in the process of putting up a 2,500-square-foot steel building with two bay doors and a shop on his acre-plus property.

As for expanding the business, he believes there is opportunity in northern Nevada, but he wants to maintain the family atmosphere.

“Whatever we do, I want people who share the same dedication and mindset that I have,” he says. “We want to treat people fairly — to stand behind our work and have no hidden fees. No surprises for the customer when we are done.”



Mickey Castonguay and his son Mickey II watch the camera's progress on a SeeSnake monitor.

**"I REALLY HAD NOT THOUGHT ABOUT FINDING BUSINESS WITHIN THE REAL ESTATE COMMUNITY. BUT I REALLY LIKE BEING A PART OF IT.**

**I PARTICULARLY FIND THE AGENTS TO BE EXTREMELY ORGANIZED AND KNOWLEDGEABLE, AND THEY WANT TO TAKE CARE OF THEIR CLIENTS."**

Mickey Castonguay

**READY TO HELP**

Castonguay has also built a good reputation with the local supply houses, and they will frequently refer plumbers to Absolute Drain Service. The owner of the largest warehouse in town even has Absolute Drain Service take care of his own personal property.

While the company primarily does residential service, it also has small commercial clients and has done municipal work within northern Nevada. For example, the company was called out to restore operation of the sewer system in the city of Gerlach

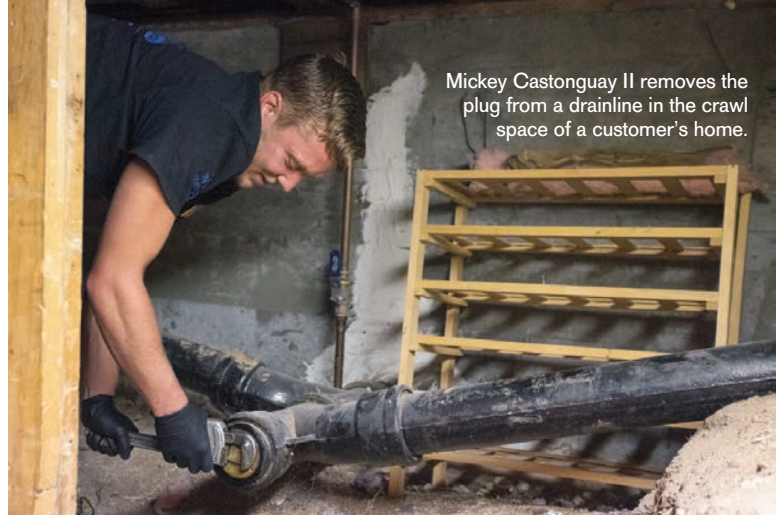

Mickey Castonguay II removes the plug from a drainline in the crawl space of a customer's home.



## PIPE BURSTING PROS DEPEND ON HAMMERHEAD®

“ We worked very closely with HammerHead Trenchless Equipment in the development of their new 100XT static pipe bursting system, and we couldn't be happier with the final result. It's fast, reliable, and backed by customer support that has always been quick to respond when we have a question. Municipalities are catching on to the advantages of pipe bursting, and our 100XT positions us to take advantage of pipe bursting's growing popularity.”

**MARK DIMICHELE,**  
Owner, D & D Water & Sewer, Canton MI

# EQUIPMENT. EXPERTISE. SUPPORT.

HammerHead Equipment products and expertise take the guesswork out of pipe bursting. And legendary factory support puts even the toughest pipe bursting jobs within your reach.



Find your local dealer at  
[hammerheadtrenchless.com](http://hammerheadtrenchless.com)  
or call 800-331-6653



MOLING | RAMMING | BURSTING | HDD ASSIST | WINCHES | CIPP

©2017 Earth Tool Company, LLC

A Charles Machine Works Company

Mickey Castonguay looks for defects in a customer's drainline.

**"THAT IS WHAT I LOVE ABOUT THIS — WHEN I FIX SOMETHING FOR MY CLIENTS, THEY ARE SO GRATEFUL."**

Mickey Castonguay

during an ice storm, and at Lovelock Correctional Center in Lovelock, Nevada, the company repaired service when the water system failed. They have also done work in adjoining Douglas County and South Lake Tahoe.

Castonguay also makes himself and his team available to other plumbing companies on difficult jobs, even during off-hours.

"I've had phone calls from plumbers on night calls, asking for my advice on difficult problems, and we will even go out to help for a major concern," he says. "We do try to offer 24/7 service, with the exception of Sunday. We take Sunday off. Quality time with the family is important."

Absolute Drain Service has informal preventive maintenance agreements with many clients for whom technicians return on a regular basis to inspect lines and remove roots to avoid stoppages.

Castonguay notes that since Reno is an older city, he still sees a lot of the Orangeburg pipe that was used up until around 1970. It often needs to be replaced.

"We also see clay pipe, asbestos cement and concrete, all with joints and lots of roots. These we jet out and then use RootX, which works very well.

"Inside the house, you find cast iron and some plastic. When handling the older pipes, you have to use kid gloves."

Castonguay's crew uses a RIDGID self-leveling microDrain camera with a CS10 monitor, and two Insight Vision Cameras self-leveling mini cameras. They also use a RIDGID locator and Spartan Tool drain equipment.

## GOOD PEOPLE

The right equipment is only part of the battle. Hiring the right people is even more important. Absolute Drain Service started as a one-man operation, but Castonguay now has six employees. His two young sons and one of his nephews — Mickey, Ian and nephew Bobby Reedholm — entered the business on a part-time basis and are now full-time employees doing drain cleaning and inspection work.

"Every plumber I know is trying to hire someone," he says. "I keep suggesting that they go to the high schools and talk to the kids who are in sports. Talk to the wrestling coach where he has students training through intense programs. Talk to the boys in the other sports. These are potential employees if they have a chance to learn about the industry."

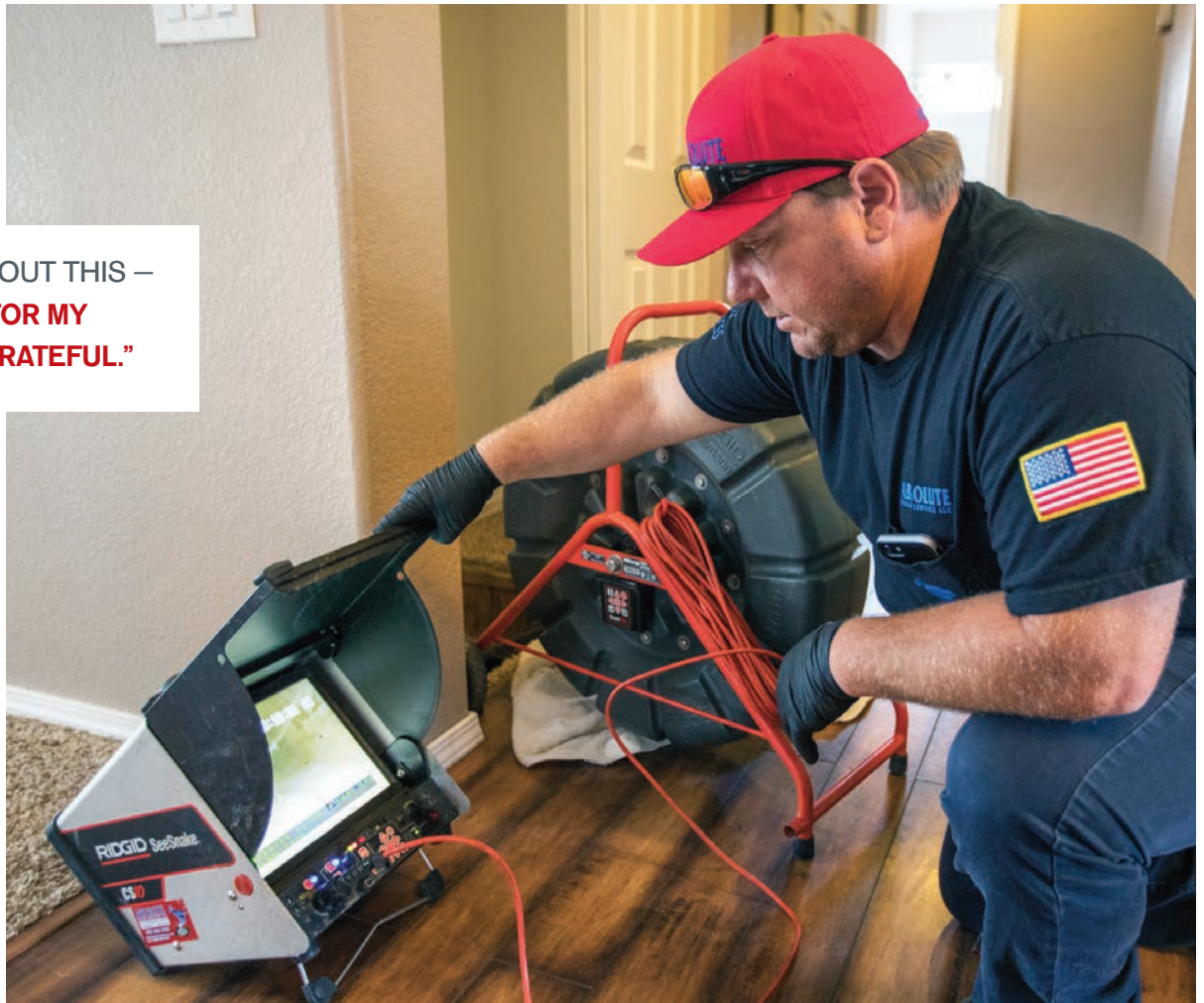

"It takes a lot of money to train someone, but if you take care of employees, treat them fairly and pay fairly, they will do well. This is important for the industry."

Castonguay says the hands-on training and experience he received at Affordable Drain Service back in San Diego has benefitted his own company. "It gave me the confidence to know what I could do for myself."

He says that the thing he most enjoys about his job and running his own company is that people are so happy when he shows up to handle a problem.

"That is what I love about this — when I fix something for my clients, they are so grateful.

"I have to say this is the only job I've ever had where every day people say thank you and are happy to see me. They are happy when the toilet will flush properly, or the shower will drain, or when they don't have to spend a fortune to fix something we have helped to maintain. Those are the times when people want to say, 'Thank you for being there. Thank you for taking care of my problem.'" **C**

## featured equipment

**Insight Vision Cameras**  
800/488-8177  
[www.insightvisioncameras.com](http://www.insightvisioncameras.com)

**RIDGID**  
800/769-7743  
[www.ridgid.com](http://www.ridgid.com)

**RootX**  
800/844-4974  
[www.rootx.com](http://www.rootx.com)

**Spartan Tool**  
800/435-3866  
[www.spartantool.com](http://www.spartantool.com)  
(See ad page 84)

**US Jetting**  
800/538-8464  
[www.usjetting.com](http://www.usjetting.com)

# It's all in the touch...

Utilizing an operator-friendly, intuitive touchscreen interface, AssetDMS condition assessment software makes data collection and analysis more second nature than work.

Collection of data is highly streamlined, simplified and accurate with the use of built-in user prompts so critical information is always captured.

AssetDMS is compatible with a wide range of manufacturer's CCTV systems.



- Import/Export from ANY certified PACP/LACP/MACP database
- No need to memorize all the codes and rules
- PACP reference photos for codes
- Extensive reporting and easy to understand analysis tools

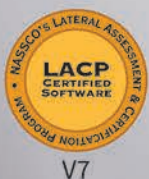

Call or click today for more information or a free demonstration of the AssetDMS software suite or any of our full range of CCTV inspection technology.



4806 Wright Drive, Bldg C, Smyrna GA 30082  
p: 800.443.3761 | 770.435.8991 f: 770.435.0402  
sales@trio-vision.com · www.trio-vision.com

**trio-vision-ary**  
CCTV Inspection + software technology



WHY DO LESS WHEN YOU CAN **ACHIEVE** SO MUCH MORE?

**Picote Coating System** A simple way to renew small diameter drains



Locate your reseller at [picotesolutions.com](http://picotesolutions.com) or call 219 440 1404 for further information.

NEW: Picote Worldwide Training Center now open in Anderson, SC.

THE SMART CUTTER™



PRODUCT OF THE YEAR 2012

# THE CABLE CENTER 1-800-257-7209

MIDWEST'S LARGEST FACTORY AUTHORIZED  
REPAIR CENTER FOR GATORCAM, GEN-EYE & SEESNAKE

**24**  
HOUR  
TURNAROUND

**FREE  
FREIGHT  
ON ALL RIDGID  
CAMERA  
KITS**

## RIDGID's CS10 Digital Recording Monitor

- USB Thumb Drive
- 12.1" Daylight Readable Display
- Multi Mode Recording  
take snapshots, record full video & lean video
- Software Integrations  
with SeeSnake HQ & RIDGIDConnect™



CALL FOR  
SPECIAL  
PRICING ON  
ALL CAMERA  
KITS!

THE CABLE CENTER · 8318 OLIVE BLVD. · ST. LOUIS, MO 63132 · 314-993-3099 · [www.thecablecenterinc.com](http://www.thecablecenterinc.com)



# LOWER PRESSURE SHOULDN'T MEAN LOW EXPECTATIONS.

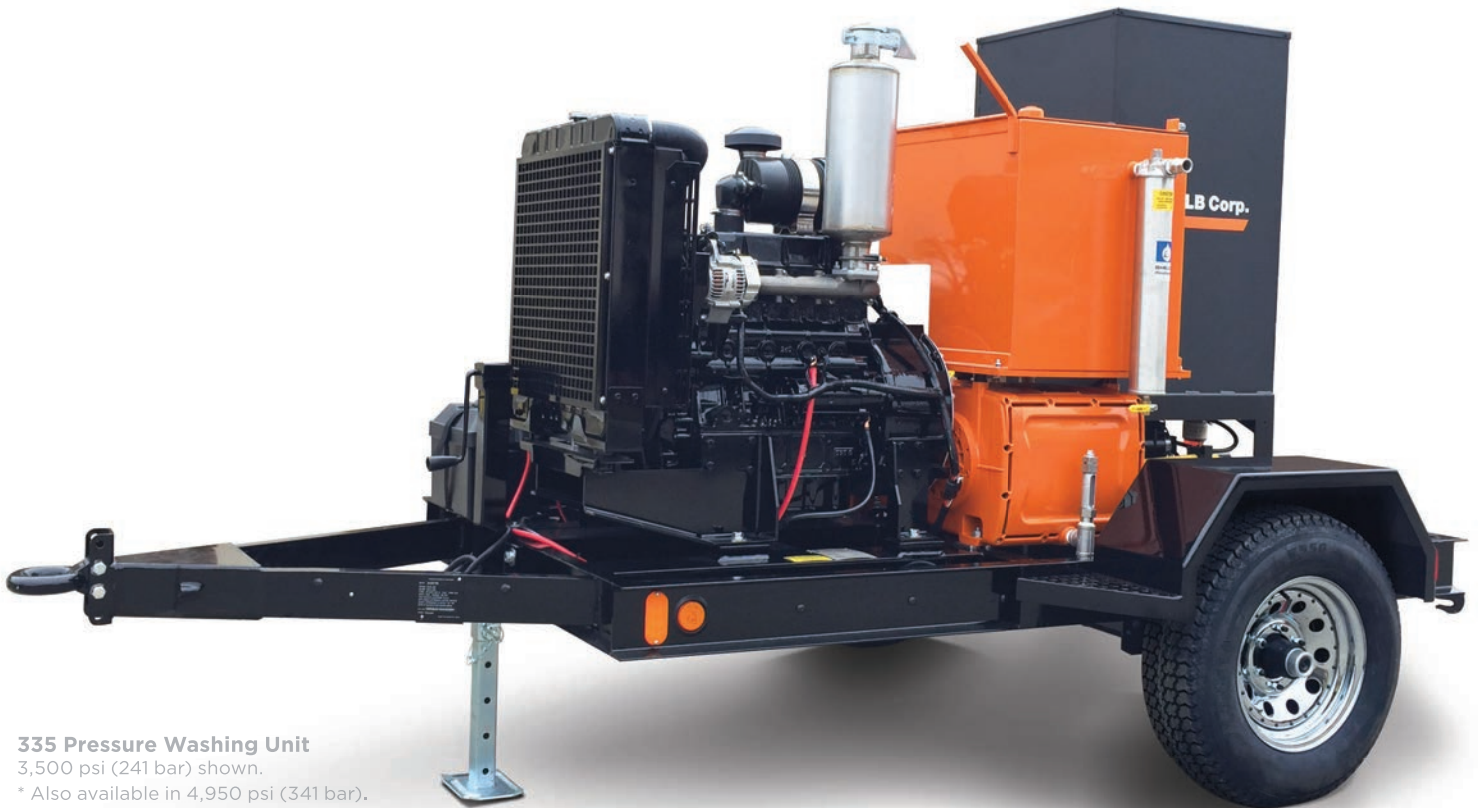

**335 Pressure Washing Unit**  
3,500 psi (241 bar) shown.  
\* Also available in 4,950 psi (341 bar).

## THE NEW 335 PRESSURE WASHING UNIT. BUILT TO THE ORANGE STANDARD.

There seems to be an acceptance that low pressure water jetting systems are fragile and prone to breakdown. We don't believe just because it's not ultra-high pressure, it should get a pass on reliability. In fact, it's exactly why we've built the new NLB 335 3,500 psi (241 bar) hot water pressure unit. The 335 is built to the same standards as our industry leading high pressure systems and building reliability to our standards means profitability to you. If you're ready to learn about how a real unit can operate, look at the NLB 335. Just another reason why the industry gold standard is orange.

**NEW!**  
Now offering more jetting accessories for added versatility & applications!



LEADING WATER JET TECHNOLOGY™

US (800) 227-7652  
Intl. +(248) 624-5555

[NLBCORP.COM](http://NLBCORP.COM)



Jeramie Chisum of Washington-based Allied Plumbing and Pumps feeds a Viztrac inspection camera from Amazing Machinery into a lateral line cleanout.

# Adding Value, Not Upselling

Smaller, less-expensive inspection cameras reduce equipment costs and lead to pipeline repair projects

By Ken Wysocky

An old adage says that, generally speaking, you get what you pay for. But as Ron Smiley discovered, it's also possible to flip that saying on its ear — get good value and improve customer service — by paying less, not more.

As evidence, Smiley — the owner of Allied Plumbing and Pumps, based in Wenatchee, Washington — points to Viztrac pipeline inspection camera systems made by Amazing Machinery. The company owns several of the cameras, which come in three good-better-best models called the Basic, Pro and Max. Standard features on each model include a 3/8-inch-diameter push cable, a color LED monitor, a cable reel and stand, a stainless steel camera body with a sapphire lens, a 1 3/8-inch-diameter waterproof camera head, six LED lights with a dimmer, and a vision angle of 60 degrees.

What really appealed to Smiley, however, was the cameras' price points, which start at \$1,495 for the Basic and range up to \$2,395 for the Max. It's not that Smiley doesn't invest in expensive equipment; the company owns a wide array of more expensive cameras made by Spartan Tool, Envirosight, RIDGID and Aries Industries that are used in conjunction with various services the company provides, such as cleaning municipal sewer lines, pipe bursting and CIPP lining.

But for simpler applications, like inspections of clogged residential lateral lines, the Viztracs offer a great blend of performance and customer service. Moreover, because they're so relatively inexpensive, Smiley says he doesn't need to charge residential customers extra for inspections related to clogs, which helps him be more competitive pricewise. (He still charges for things such as looking at laterals for home presale inspections.)

money machines

- OWNER:** Allied Plumbing and Pumps LLC
- MACHINES:** Viztrac pipeline inspection camera systems built by Amazing Machinery
- FUNCTION:** Inspecting residential lateral lines
- FEATURES:** 100 feet of 3/8-inch-diameter push cable, color LED monitor, a cable reel and stand, stainless steel camera body with sapphire lens, 1 3/8-inch-diameter waterproof color camera head, six LED lights with dimmer, vision angle of 60 degrees
- WEBSITE:** [www.alliedplumbingandpumps.com](http://www.alliedplumbingandpumps.com)
- COST:** Between \$1,495 and \$2,395
- AMAZING MACHINERY WEBSITE:** [www.amazingmachinery.com/index.html](http://www.amazingmachinery.com/index.html)

“The main benefit is that we can cost-effectively put one of these cameras in our trucks and get an immediate return (on investment) from them,” explains Smiley, a fourth-generation plumber. “Because they're relatively inexpensive cameras, we don't need to charge more to cover that investment. It's a lot harder to do that on a piece of equipment that costs \$10,000.

“They basically changed our business model in the sense that before, we looked at inspections as an opportunity to upsell services. Now, we're able to look at them more as adding value. And I see a higher return on the added-value business model compared to the upsell business model.”

How does that work? In a nutshell, inspections often reveal problems — cracked and structurally compromised pipelines for example — that result in

CONTINUED >>

**HIGH QUALITY.  
HIGH PRODUCTION.  
HIGH DEFINITION.**



Certified ISO 9001:2015 and ISO14001: 2015.

**Look Closer.**



(800)-656-4225 | [www.rapidview.com](http://www.rapidview.com) | Past Proven. Future Ready.



## The Solution

CAN'T FIND A LEAK?



**POWER  
SMOKER™**

- Quickly and safely locate leaks in indoor plumbing systems. Model available for sewer line testing.
- Uses the ONLY tested safe smoke on the market

NEED A VAC THAT DOES IT ALL?



**VAC 250**

- 250 or 500 gallon units with compact configuration creates easy access to places large hydro excavation systems can't reach.
- Ideal for cleaning out catch basins, potholing, exposing buried utilities, and miscellaneous jobs on property that requires extra care, such as parks and golf courses.
- Years of dependable use provided by top of the line components, including Cat® diesel or Kohler® gas engines, Gardner Denver® blowers, and Giant® pumps.

**HURCO**TECH.COM  
800-888-1436

bigger and more profitable jobs, such as pipe relining or pipe bursting. “The costs of jobs like those can range from \$1,000 for a point repair to \$20,000 for a pipe replacement (lining),” he says.

The cameras bring another benefit to the table: They protect the company from service callbacks. Essentially, if a camera inspection reveals a problem such as roots penetrating cracks in a pipe and the customer only wants to pay for unclogging the drain instead of opting for a long-term solution to the problem, Smiley won't warranty his work. As such, customers who decline to fix the problem have to pay for service callbacks.

“They basically changed our business model in the sense that before, we looked at inspections as an opportunity to upsell services. Now, we're able to look at them more as adding value. And I see a higher return on the added-value business model compared to the upsell business model.”

Ron Smiley

“It puts the liability on the customer because they choose the level of service they want,” he notes. “If they want to do just a simple in and out, we tell them ‘You're the customer — you're the boss.’ They take the risk.”

Furthermore, the cost of the Viztracs is often less than a repair for one of Smiley's more expensive cameras. If a Viztrac breaks down, which is bound to happen sooner or later because technicians are hard on equipment and the cameras are subject to harsh working conditions, it's not as big a setback as when a much pricier camera breaks down, he says. In addition, the camera systems are easy to transport; the weight ranges from about 48 pounds for the Basic model up to approximately 65 pounds for the Max.

Smiley got a good look at a Viztrac camera at the Water & Wastewater Equipment, Treatment & Transport (WWETT) Show two years ago. “We had been bouncing around between various manufacturers, trying to find the right combination of customer service and durability — and the right price point,” he explains. “We tried the Viztracs out at the WWETT Show and bought two units. We had great success and started ordering more of them. We can buy four of them for the price we were paying for other cameras.”

Of course, more expensive cameras offer higher-level bells and whistles, such as better high-definition monitors and self-leveling cameras. But, Smiley says the Viztracs are more than adequate in the area that counts most: showing customers what's going on with their pipelines. “A picture is worth a thousand words,” he says, noting how actually seeing a problem helps customers feel comfortable with a diagnosis as opposed to feeling suspicious they're being scammed for a very expensive and possibly unnecessary repair.

“They're a great selling tool for us,” adds Smiley, who runs eight service vehicles and serves the north-central region of Washington. He also relies on Spartan Tool cart-mounted jettors, a Spartan Tool Warrior trailer jetter, a hot-water jetter built by Jettors Northwest, pipe bursting systems made by Hammerhead Trenchless and RODDIE, and horizontal directional drilling machines made by RODDIE.

“We have nicer cameras with more features that do a wider range of inspections,” he concludes. “But for the average residential lateral line, the Viztracs are great. We get a lot more for less.” **c**



# BEST-IN-CLASS EDUCATION

Looking for professional development? The education sessions at WWETT Show 2018 are just what you need. 110 sessions over three days will cover a wide array of industry and business topics. You can choose certification classes, and new for 2018 - technical tours to area facilities. And be sure and look at the lists of available CEU credits. WWETT Show education - it's a great way to up your game.

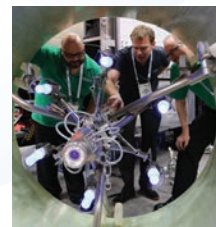
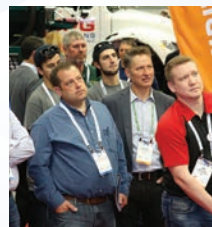

EDUCATION: FEBRUARY 21-23  
EXHIBITS: FEBRUARY 22-24  
INDIANA CONVENTION CENTER

## WHY SHOULD YOU ATTEND?

- ✓ **Explore the Marketplace** for tools and resources you need for your business
- ✓ **Education** taught by some of the best and brightest in the industry
- ✓ **Events** to network with your peers - or just kick back with friends.

REGISTER TODAY AT [WWW.WWETTSHOW.COM](http://WWW.WWETTSHOW.COM)





THIS IS THE END OF THE  
**OVERHEAD MESS**

VISIT OUR WEBSITE  
FOR AVAILABLE ZIP DRAIN  
KIT CONFIGURATIONS

888-594-7372  
WWW.ZIPDRAIN.COM

## HOW IT WORKS

Clear and unclog overhead drains with no mess

1



CLAMP TO CLEAN OUT DRAIN

2



ATTACH DRAIN HOSE

3



CUT HOLE IN DRAIN CAP

4



OPEN VALVE AND DRAIN CONTENTS

**T&T TOOLS**

**T&T Tools, Inc.**

Fax: 800.521.3260

Email: sales@mightyprobe.com

**800.521.6893**  
**www.MightyProbe.com**

Call for a FREE Catalog



Call for a FREE Catalog

### HOOKS...

- > Several different styles of heat-treated hooks are available
- > Top Poppers are great to open manhole covers
- > The Handy Hooks allow two handed use



### PROBES...

- > Insulated, standard, and specialty soil probes
- > Metal shaft sizes: 3/8" round, 3/8" hex, or 7/16" hex
- > Replaceable tips are threaded on and hardened
- > A "slide" allows the handle to pound the shaft into the ground

# SCOOTER

## VIDEO INSPECTION SYSTEMS

20843 Santa Lucia  
Tehachapi, CA 93561  
Fax: 661.822.8917

# INDUSTRIAL QUALITY, MADE IN AMERICA

"MOSTLY"



### Tired Of Squinting At A Tiny Monitor?

Get An  
Attaché  
With A

# 15" LED Hi-Def Monitor

- Giant 15" LED hi-definition color monitor
- High quality SD/DVR recorder
- Compatible with other camera systems



SD/DVR Recorders

Storage

### NEW

18' Extension



### Stick Camera

180° Rotation



- Lithium ion battery powered
- 18 ft. pole extension
- 180° head articulation up or down
- Wireless communication (Includes preprogrammed WiFi cell phone on armband)
- Fully submersible camera head
- Digital zoom
- Chargers included.

Wireless



### NEW



### Anti-Skid Legs

They simply clip on.  
No glue or screws.

# \$39.95

For a Set of 4

### NEW CONFIGURATION



- Wireless to cell or other device
- Lithium ion battery powered
- Solid 8+ hours use on charge
- WiFi cell phone and arm band included! 

## "Simplify Your Life!"

SCOOTERS ARE EASY TO USE, TOUGH AND DEPENDABLE.  
DON'T LEAVE THE SHOP WITHOUT ONE.



# 800.772.6165

# www.tvinspection.com

# 7 Great Reasons to Hire a Veteran

Former military personnel bring skills and experience that can help build your business

By Dana Manciangli

Unemployment continues to plague many veterans once they leave the military. Despite their years of dedicated service and a wide variety of work and life skills, veterans are struggling to secure full-time jobs to support themselves and their families.

According to Joseph Kernan, chairman of NS2 Serves and retired vice admiral, U.S. Navy, “Hiring a veteran not only provides your company with a devoted employee who has the potential to become a highly productive member of the team, but you’re also giving a deserving veteran a fresh start in post-military life and a chance at a fulfilling career.”

## WHY NOT WASTEWATER?

Veterans can thrive in a wide variety of work settings, including the wastewater industry, where many of the skills they’ve learned over the years may translate well to a service business. They may know how to operate large trucks or equipment, communicate well with technicians and your customers, and are often trained in technology areas that could bring added value to your operation.

“This is why SAP National Security Services established the nonprofit NS2 Serves: to train and employ veterans in high-tech careers,” Kernan says. “Through this program for predominantly enlisted men and women, we prepare graduates with the skills that hiring managers and organizations look for in a highly qualified, technically trained and dedicated employee.”

Asked why employers should hire a veteran, he suggests seven compelling qualities that demonstrate why a veteran should be your next pick.

**“Hiring a veteran not only provides your company with a devoted employee who has the potential to become a highly productive member of the team, but you’re also giving a deserving veteran a fresh start in post-military life and a chance at a fulfilling career.”**

Joseph Kernan

### 1. Veterans strive to be leaders

In the military, leadership is continually fostered until it becomes an ingrained attribute. Veterans respect and understand the roles of leaders and willingly accept and seek leadership opportunities. Most importantly, there is a clear understanding of a preeminent responsibility to those entrusted with leadership roles — lead by example and in a way that they would like to be led.



### 2. Veterans know how to work as a team

Working successfully in a team is considered an essential skill in most workplaces; it’s also the foundation on which safe and successful military operations are conducted. Veterans have developed an uncompromising responsibility to their peers, subordinates and superiors alike. They understand that there is “no I in team” and that success is invariably related to the depth of teamwork.

### 3. Veterans are trained to quickly learn new skills and concepts

While in the service, members of the military are continually trained in a multitude of cross-functional skills. The demand for both administrative and occupational skills is high, and the ability to adapt to technological enhancements is essential. No matter what their job assignment, veterans must master the operations and react quickly to flaws and failures.

### 4. Veterans are mission/goal oriented

In the military, the mission is paramount. Veterans have been trained to adapt to complex tasks that are inherent in office and field settings. Their sense of duty, responsibility and accountability for job performance and mission success is an enduring priority. The culture and training in our military continues to breed success and respect around the world.

### 5. Veterans have the ability to perform in high-stress situations

In today’s fast-paced work environment, having the ability to persevere under difficult or stressful circumstances is crucial. Veterans are trained and expected to perform under stress and still accomplish tasks in a timely and effective manner. They must do so with the resources at hand.



# WATERBLAST PROTECTION

PROTECTIVE CLOTHING - WITH THE STRONGEST FIBER IN THE WORLD!



Use your favorite footwear and TST Gaiters!

+ **VENTILATION AVAILABLE**  
GOOD WORKING CONDITIONS!

+ **FLAME RETARDENT**  
AVAILABLE TO ORDER

+ **FAST AND EASY GEAR UP**  
SAVES VALUABLE TIME!

+ **PROTECTION UP TO 43500 PSI**

+ **CE CERTIFIED**  
PIN AND ROTATING AT 0,5 m/s



Protection level	Pressure bar (psi)	Flow l/min (gpm)	Nozzles		RPM	Distance mm (in.)	Linear Speed m/s (in./sec)	Result
			n	Dia. mm (in.)				
20/30	2000 (30000)	17.9 (4.7)	1	0.8 (.031)	-	75 (3)	0.5 (20)	No penetration
20/30	3000 (43500)	19.5 (5.2)	2	0.6 (.024)	3000	75 (3)	0.5 (20)	No penetration

Find Distributors, News, Movies and E-catalogues at:

**WWW.TST-SWEDEN.COM**

## 6. Veterans are able to adapt accordingly

While in the military, veterans undergo rigorous training programs to become experts in a wide range of skills and concepts that are applicable in a civilian work environment. Being able to adapt to changing situations is imperative to mission success and, when transferred to the workplace, it ensures a highly successful employee. While military duties stress teamwork and group productivity, they also build individuals who are able to perform independently when the situation demands it.

## 7. Veterans have strong communication skills

Veterans have learned to work effectively side by side with individuals regardless of race, gender, religion, economic status, geographic origins, and ethnic and cultural backgrounds. Regardless of varying intellectual and physical abilities, each individual is respected for his or her critical role in the organization. Military personnel are taught to have a questioning and thoughtful mentality, and they are not afraid to offer perspectives and recommendations to supervisors in a respectful manner.

## GREAT WORK ETHIC

Kernan asserts, "From the day they begin their training, military personnel are instilled with a strong sense of character and work ethic. They are able to fill leadership voids or follow direction until the goal has been achieved."

He believes every company should look to veterans when the time comes to grow or fill vacated positions, and he calls on business owners to help support those who preserve our values and security. For more information on getting involved with NS2 Serves, go to [www.ns2serves.org](http://www.ns2serves.org).

## ABOUT THE AUTHOR

Dana Manciangli is a career expert, Fortune 500 sales and marketing executive, member of the board of Junior Achievement, and author of Cut the Crap, Get a Job! Contact her at [www.danamcangi.com](http://www.danamcangi.com).

*Happy Holidays* From All Of Us At NozzTeq

## Recycle Water Friendly

BOOTH 1454

### Manta™

Equipment Engineered for Long Lasting Performance™

**CALL TODAY FOR AN ON-SITE DEMONSTRATION**  
Call For A FREE DVD

Taking Science to the Sewer!™

[www.nozzteq.com](http://www.nozzteq.com)

Toll Free 1.866.620.5915

# See what you've been missing

(800) 446-3392 ~ [info@vxmt.com](mailto:info@vxmt.com)

vCam-5 Inspection System



512Hz Sonde  
Locatable Pushrod  
High Resolution Cameras  
500GB Hard-drive

vCamMX Mini Inspection System



512Hz Sonde  
Locatable Pushrod  
High Resolution Cameras  
Direct to USB recording

vScan Sonde Locator/Utility Avoidance Tool



512Hz & 33kHz Locator  
Avoid energized cables

Call us for your no obligation on-site demonstration!

**VIVAX**  
**METROTECH**

Vivax-Metrotech Corporation

3251 Olcott Street  
Santa Clara, CA 95054, USA

Toll Free: 800-446-3392  
Fax: +1-408-734-1415

Email: [sales@vxmt.com](mailto:sales@vxmt.com)  
[www.vivax-metrotech.com](http://www.vivax-metrotech.com)



**USBUSA**

## USB-USA Is NOW OPEN to Fulfill All Your Sewer Cleaning Nozzle and Root Cutting Needs!



We focus on offering **high quality** sewer cleaning equipment that is **reliable**, highly **efficient** and **powerful** but most importantly **affordable**. Our innovative products are designed and manufactured by USB-Duesen in Germany and distributed throughout the globe. USB-USA's product line includes sewer cleaning nozzles with 3D fluid mechanics, Turbo Chain Cutters for root cutting and other accessories.

**USB-USA services and repairs all USB equipment.**

Contact Us Today!

1-844-285-5770 | Fax: 678-649-1766 | [info@usb-usa.com](mailto:info@usb-usa.com) | [www.usb-usa.com](http://www.usb-usa.com)



# Quality, Reliability and Affordability in a single machine.

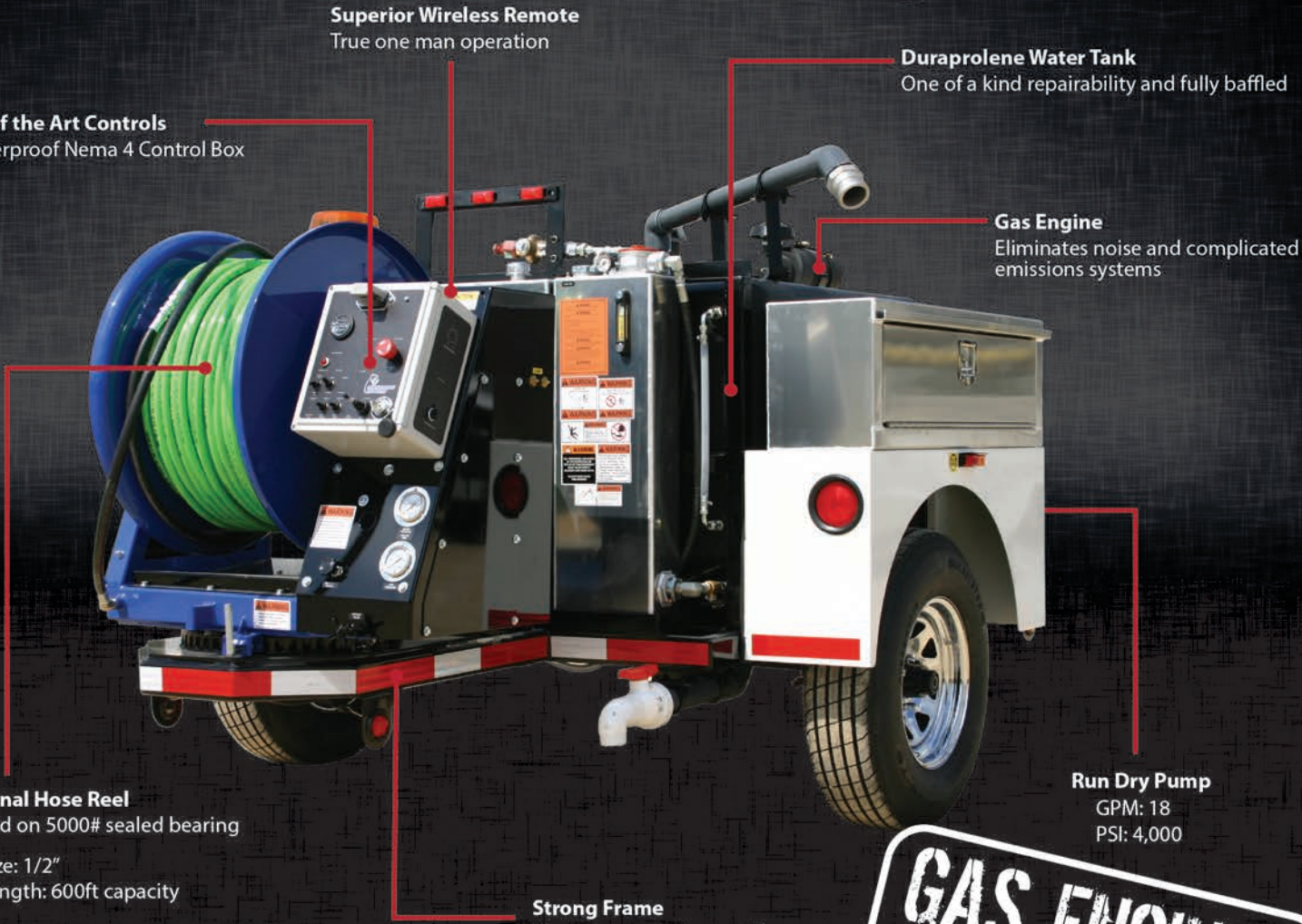

**Superior Wireless Remote**  
True one man operation

**Duraprolene Water Tank**  
One of a kind repairability and fully baffled

**Gas Engine**  
Eliminates noise and complicated emissions systems

**State of the Art Controls**  
Weatherproof Nema 4 Control Box

**Run Dry Pump**  
GPM: 18  
PSI: 4,000

**Rotational Hose Reel**  
Mounted on 5000# sealed bearing  
Hose Size: 1/2"  
Hose Length: 600ft capacity

**Strong Frame**  
Made from tubular steel for superior durability

**GAS ENGINES  
NOW STANDARD  
NO NEED FOR TIER IV**



## MONGOOSE MODEL 184

*Other units and configurations can be found on [mongoosejetters.com](http://mongoosejetters.com)*

Mongoose Jetters delivers industry leading high pressure jetting equipment that is purposefully built for the plumbing contractor market. Quality, service and a wide variety of equipment and options keep our customers operational and profitable. Mongoose Jetters stands behind its promise to provide customers with...

**“SERIOUS MACHINES FOR A SERIOUS BUSINESS”**

Contact Us for Updated Pricing Details  
**877.735.4640**

# A Step-by-Step Guide to Vacuum Tank Inspection

Take the necessary steps to ensure your vacuum system is functioning properly and won't fail you on the job site

By Ronnie Tamez

**V**acuum tanks are subject to significant stress as you load and unload wastewater and debris. Failing to properly maintain them can lead to serious problems.

Constant changes in pressure and vacuum, combined with the sludges, grit and other foreign objects passing through the valves, can weaken many points in the tank. So, it's important to clean out the tank regularly and go beyond your quick daily visual inspection.

To get started, check vacuum gauges to verify all the stored energy has been released. This means there is no pressure or vacuum stored in the tank. Be sure to put the pump into neutral to dump vacuum or pressure. You can also open the load valve to equalize the pressure and release stored energy.

**Vacuum and pressure gauges:** Not much goes wrong with these. Clean the glass and make sure gauges haven't been damaged by low-hanging branches as you negotiate driveways.

**Manways:** Before opening the manways, check tank gauges to be sure the tank is not under pressure or vacuum. Serious injury or death can result if this precaution is not taken. While most manways are operated manually, there are a few different options including pneumatically operated units. When opening the manway, check the gasket for wear. Look for chunks that are missing or dried out as well as brittle O-rings. Replace the gasket and O-rings as needed. For a steel tank manway, use a wire brush to clean debris away from the sealing edge to create a more airtight seal. Leave manways open throughout the inspection.

**Primary and secondary valves:** While the pump is pulling vacuum, sewage must never enter the pump. If by some off chance the primary and secondary valves fail and sewage is allowed to enter the pump, the safety coupler is designed to break and save the pump. That's if you're lucky. Unlucky would be vanes breaking in the pump or the pump "grenading." Grenading is where the vanes not only break, but they also explode out of the pump casing and send parts flying everywhere. This is a violent and dangerous explosion. Never remove or bypass these safety components that protect your pump.

Typically, five wing nuts hold down the primary valve, which is usually located along the top of the tank near the front. You'll open these like you would the manways and clean and inspect the gasket, replacing as needed. A cage holds a steel or plastic ball. This ball is designed to stop vacuum to the pump in case the tank is too full and to prevent sewage from entering the pump and causing expensive damage. Be sure the ball is not dented and the cage is clean. Cleaning wipes can lodge in this area and cause problems.

The secondary valve is connected to the primary through vacuum pipes and plumbing, typically with three wing nuts holding the cap on. Remove the cap and take care of the gaskets and sealing surfaces. Check the steel or plastic ball, and replace as needed.

**Prefilter:** Some people choose not to use a prefilter on their pumps. Most have the traditional setup utilizing the primary shut-off valve, secondary shut-off valve, and then the pump. From time to time, a piece of gravel or rust will come through the safety valve and the debris will go through the pump. A prefilter offers added protection to keep debris out of the pump. If you have a prefilter, remove the screen, hose it off, and replace it as part of your maintenance protocol.

**Check baffles and welds:** Here's where confined-space safety precautions come into play. Follow the appropriate procedures, and if you're not clear about them, stop the inspection now and get familiar before proceeding. Enter the tank to inspect the integrity of baffles and welds. Make sure they are not separating. A dropped baffle can make it very difficult to off-load and can be very messy. And baffles add crucial structural strength to your tank when it is under vacuum.

**Oil-catch muffler:** This muffler catches exhaust from the pump and collects the oil used by the pump. Drain this daily to avoid leaving oil spots on driveways or an oil blast mark.

## WRAPPING UP

After the tank inspection, close manways and valves. Turn the pump on, and pressurize the tank. Check for leaks and tighten seals as needed. Check pressure and vacuum relief valves to make sure they are opening at the pump/tank manufacturer's recommended settings.

Run the pump to check that the oilers are functioning properly. Look for about a drop a second at operating speeds. I highly suggest getting automatic oilers. My first vacuum truck had manual oilers. I would set my oil speed at a drop per second, but after 30 minutes of pumping, it would be running too fast. Automatic oilers maintain the preset speed the entire job.

Shut the pump down and put the three-way valve into neutral. Verify with the gauges that there is no stored pressure or vacuum. Check to be sure the valve operates without binding and excessive force needed to operate. Also, make sure there are no leaks; tighten as needed. Tanks in colder climates often have heated valves, which are warmed by the engine coolant. Be sure to inspect these hoses.

Inspect steps and handholds to make sure welded points are not starting to crack. Also check that antislip surfaces are gripping. Look for signs of cracking and leakage around plumbing joints from the tank to the pump, all the way through the three-way valve to the exhaust. Address any problems you find. **C**

## ABOUT THE AUTHOR

Ronnie and Jennifer Tamez are owners of First Call Septic Services in Battle Ground, Washington.

# ALLAN J. COLEMAN

SINCE 1905

**Call us today!**  
**773-728-2400**

5725 North Ravenswood Avenue • Chicago, IL 60660 • [info@allanjcoleman.com](mailto:info@allanjcoleman.com) • [www.allanjcoleman.com](http://www.allanjcoleman.com)

## Warthog® Nozzles



## CPI Products Camera Skids

### The Universal Roller Skid

The Universal Roller Skid allows you to use your push camera in ways that were not previously possible.

- For 6" - 18" pipelines.
- Keeps camera centered.
- Maneuvers through 90° corners.
- Increases depth range.
- Improves vision & lighting.
- Faster inspection.
- Protects push camera.



### The Mini Roller Skid

- For 4" - 6" pipelines.
- Maneuvers through corners.
- Great with cast iron pipes.
- Improves vision.

## Turn ANY push camera into a Jetter Camera with the JetCam Adapter.



**Repair Center for: RIDGID SeeSnake, Gen-Eye, Radiodetection, Electric Eel, Vision Technology & Insight Vision Cameras Fast Turnaround Time**



**Eagle 200**  
200 gallon, 12 gpm, 3000 psi

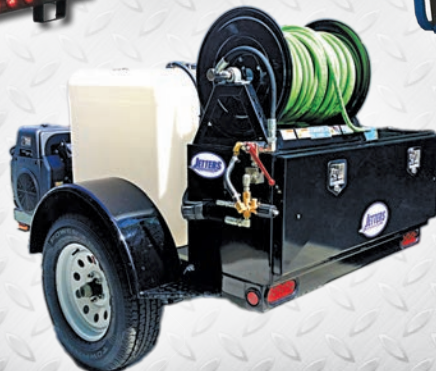

**Brute 150**  
150 gallon, 9 gpm, 4000 psi

**Mountable-Skid**  
9 gpm, 4000 psi



**Portable-Cart**  
9 gpm, 4000 psi



Products  
Manufactured  
By



**OLDEST NAME IN THE BUSINESS**  
**— Over 100 YEARS OLD —**

BRUTE POWER | BRUTE PERFORMANCE



12 GPM 3000 PSI  
OR 9 GPM 4000 PSI

MOUNTABLE-SKID OR PORTABLE-CART

**HIGH-FLOW JETTERS**

- Complete control of all jetting functions from the Control Panel
- Ability to run from the on-board tank, or connect to a larger tank
- Trailer Jetter Performance in a Compact Package



**The Brute Jetting System:**

Choose **9-GPM 4000-PSI**  
or **12-GPM 3000-PSI**  
Order as a Portable-Cart  
or choose Mountable-Skid

Come See Us At The  
wwett BOOTH  
1404

**CALL: 877-901-1936**

**www.JettersNorthwest.com**

Cleaner

Cleaner

Cleaner

Cleaner

Cleaner

Cleaner

Cleaner

Cleaner

Cleaner

# Socially Accepted



[facebook.com/CleanerMag](https://facebook.com/CleanerMag)

[twitter.com/CleanerMagazine](https://twitter.com/CleanerMagazine)

[youtube.com/CleanerMagazine](https://youtube.com/CleanerMagazine)

[linkedin.com/company/cleaner-magazine](https://linkedin.com/company/cleaner-magazine)



## Featured in an article?

# Make the most of it!

### REPRINTS AVAILABLE

We offer:

Hard copy color reprints

Electronic reprints

Visit [cleaner.com/order/reprint](https://cleaner.com/order/reprint)

for articles and pricing

**WÖHLER**

**NEW**

**WOHLER VIS 700  
HD INSPECTION CAMERA**



**Available 2018**  
[www.wohlerusa.com](http://www.wohlerusa.com)

SHAMROCK

ORDER ONLINE AT  
[WWW.SHAMROCKTOOLS.COM](http://WWW.SHAMROCKTOOLS.COM)

USE COUPON CODE "SANTACLEANER"  
AT CHECKOUT & RECIEVE 5% OFF



**"O HOLY NOZZLES"**



**vwelt** BOOTH 6528

**Best Quality. Best Price.**  
**30 DAY MONEY BACK GUARANTEE**

(800) 633-7696  
MANUFACTURING IN THE USA FOR 38 YEARS

**Professional-Grade  
Drain Cleaning Machines,  
Cables & Accessories**



**Drain Cleaning  
Machines**

- > Heavy duty construction
- > The most powerful motor in the industry
- > Quick and easy reel changeover
- > A one year rock-solid warranty

**Cables**

- > Fabricated from high quality wire
- > Most ends & couplings available
- > All sizes and lengths
- > Innercore available



**TORQUE MASTER**  
THE PROFESSIONAL CHOICE  
**COAST MANUFACTURING**

[www.coastmanufacturing.com](http://www.coastmanufacturing.com)  
**541.684.0743**

# Business Diversification – Septic Pumping, Plumbing

By Craig Mandli

## CABLE DRAIN CLEANING MACHINES

### DURACABLE MANUFACTURING COMPANY DM30

The **DM30** from **Duracable Manufacturing Company** has a double-tube frame that's constructed of an aluminum alloy for added stability when on the job. The electrical wiring runs through the top of the frame so normal wear will not expose it. The winch hook on the frame makes it easy to lift the machine with a loading ramp or crane. The machine can run 19- or 21-inch reels with options for open-spoke metal or enclosed polyethylene drums. Packages come with 21-inch reels and 100 feet of 5/8-inch drain cable. It can also run 1/2- or 11/16-inch cable, depending on the drum. Its 1/2 hp motor makes it ideal for residential jobs, floor drains, roof vents and light commercial work. 877/244-0556; [www.duracable.com](http://www.duracable.com).



### ELECTRIC EEL MFG. MODEL C

The **Model C** dual-cable sectional drain and sewer cleaner from **Electric Eel Mfg.** runs up to 200 feet of 1 1/4-inch, self-feeding dual cable in 8- or 10-foot sections that require no handling when rotating. It spins cable at twice the revolutions per minute of a continuous cable machine for maximum cleaning power in 3- to 10-inch-diameter lines for distances up to 200 feet. One-man operation means less time and labor expense. A heavy-duty, 1/2 hp motor comes standard, and 3/4 and 1 hp motors are also available. A custom-designed gearbox ensures parts availability and higher quality with lower cost. The heavy-duty, fully adjustable safety clutch keeps cable and tool breakage to a minimum and provides overload protection. Separate fold-down and carry handles allow for easy transportation as well as better balance, storage and use in crawl spaces. 800/833-1212; [www.electriceel.com](http://www.electriceel.com).

### GORLITZ SEWER & DRAIN GO 62A

The **GO 62A** from **Gorlitz Sewer & Drain** is ideal for cleaning basement drains, and it is able to get into tight spaces or through narrow doorways. With a quick turn of an Allen wrench, the machine can be broken down into separate frame and drum components for easy transportation, or to add an additional cable and drum for extended reach. It is a mirror image of the larger Model GO 68. The ball-bearing, 1/4 hp, reversible, steel-gear motor develops approximately 100 pounds of torque and cleans sewer and drainlines 3 to 4 inches in diameter and up to 200 feet long. 562/944-3060; [www.gorlitz.com](http://www.gorlitz.com).

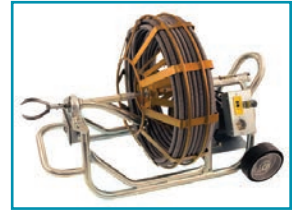

### PIPE LINING SUPPLY ULTRA HIGH SPEED

The **Ultra High Speed** drain cleaning machine from **Pipe Lining Supply** has a cable that is enclosed, turns at a high speed, and can carry a camera strapped to it to pinpoint the locations of the pipe that needs cleaning. It allows users to clean many drains per day to a level of clean that they can see while performing the work. The units are made in 1/4-, 5/16-, 3/8- and 1/2-inch sizes. The cable is reversible, providing the ability to use another approach angle to clean roots and debris. 888/354-6464; [www.pipeliningupply.com](http://www.pipeliningupply.com).

## FRANCHISE SYSTEM

### ROOTER-MAN FRANCHISE SYSTEM

The **Rooter-Man Franchise System** offers a low-cost solution to franchise ownership, with a flat-rate pricing system (no royalty on percentage of sales). Franchisees are granted an exclusive franchise license for their chosen territories, and they become part of a team of independent dealers working together under a nationally branded website and recognized trademark with proven systems for success. Franchisees receive equity in the national brand by receiving exclusive use of the Rooter-Man trademark in their territory, an appreciating investment that can later be sold or expanded. 800/700-8062; [www.rooterman.com](http://www.rooterman.com).



## PLUMBING PRODUCTS

### ENZ USA CUTTING BALL NOZZLE

The water-driven cutting ball nozzle from **Enz USA** moves easily around curves in 4- to 6-inch polyethylene, steel or concrete pipes. It can safely remove roots and mineral deposits without damaging the pipe. It works without impact but has the ability to switch to a vibrating nozzle. It is equipped with a hard metal front blade for pipes that are more than 50 percent clogged. The side blades





are self-sharpening and maintain their sharpness over their entire service life. The cutting ball operates with controlled rotation speed and is capable of running on recycled water. It is leakage-free. 877/369-8721; [www.enzusainc.com](http://www.enzusainc.com).

### NOZZTEQ MULTI-GLOBAL SERIES

**Multi-Global Series** sewer nozzles from **NozzTeq** have replaceable orifices, similar to the Ice Bear nozzle design. They have a crisscrossing front jet pattern for clearing grease, debris and ice blockages. They can be configured with up to four different front jets for general sewer cleaning or particular types of sewer obstructions. They have been used for hydroexcavation as the rear orifices can be blocked, leaving only penetrating orifices in the front. By replacing orifices as needed, overall nozzle life can be extended. Laminar flow is preserved from the truck to the nozzle end for more powerful jet streams produced at lower pressure, extending the life of the jetting equipment. 866/620-5915; [www.nozzteq.com](http://www.nozzteq.com).



### NU FLOW TECHNOLOGIES VERTICAL AND HORIZONTAL CIPP CONNECTION LINER

The **Vertical and Horizontal CIPP Connection Liner (V & HCL)** from **Nu Flow Technologies** is designed for vertical and horizontal small-diameter T and Y connection(s) for the most common

sizes in the system. It can be easily installed from upstream or downstream access with a two-man crew, allowing them to rehabilitate the entire fitting structurally with no worries of reinstating or coating failure. It has a reusable silicone bladder for multiple installations. Installation times are between 1 to 1 1/2 hours per connection, allowing technical to install six per day. 800/834-9597; [www.nuflowtechnologies.com](http://www.nuflowtechnologies.com).

### PORTABLE JETTER



### RIDGID KJ-1350 WATER JETTER

The **RIDGID KJ-1350** water jetter propels a highly flexible hose through 1 1/4- to 4-inch lines, blasting through sludge, soap and grease blockages. As users pull the hose back, it power scrubs the line, flushing debris away and restoring drainlines to their free-flowing capacity. A working pressure of 1,350 psi and flow of 1.4 gpm provides fast, effective cleaning of lines. It

comes with a 1.5 hp motor that draws a maximum of 14 amps, can run on most standard 115-volt circuits, and is CSA and UL standards approved. Users guide the hose into the drain while the thrust propels the hose down the line. Pulse action is designed to easily navigate difficult bends and traps. The pressure control valve allows for quick and easy pressure adjustment. The optional H-10 cart makes for easier transport. 800/769-7743; [www.ridgid.com](http://www.ridgid.com).

### PRESSURE WASHER AND SPRAYER

#### WATER CANNON INC. - MWBE POLY DRIVE

The **Poly Drive** twin-cylinder pressure washer from **Water Cannon Inc. - MWBE** has a Honda GX690 engine and industrial-duty General Pump TSP Series pump, producing 6,000 psi of power for commercial and industrial cleaning applications. The units are also equipped with a Gates Poly Drive long-life belt system that is laser aligned. Standard accessories include a 50-foot pressure washer hose with quick couplers for continuous washing, four quick-connect spray tips, aluminum frame, safety belt guard, and a high-rated trigger gun and wand. 800/333-9274; [www.watercannon.com](http://www.watercannon.com).



### PUSH TV CAMERA SYSTEMS

#### ARIES INDUSTRIES SEEKER

The **Seeker** video inspection system from **Aries Industries** is a compact, portable unit for drainline inspection. The easy-to-use, contractor-grade system works in 3-inch-diameter or larger pipe. Weighing only 40 pounds, the unit is self-contained with no external wiring. It can be used in conjunction with a CCTV truck. It comes with a built-in 512 Hz transmitting beacon and a bright 6.4-inch LCD screen. Users select from either a self-leveling mini-camera or a pan-and-tilt camera with a self-cleaning wiper blade. Built-in AV outputs enable inspection data to be recorded onto an SD card, DVR or a laptop using any software. Wireless controls, video transmission up to 300 feet and line tracing are available. 800/234-7205; [www.ariesindustries.com](http://www.ariesindustries.com).



#### CUES MPLUS+ XL

The **CUES MPlus+ XL** push system enables easy operation with its all-in-one setup and flexibility by quick removal of the control unit to be used separately. It includes a coiler configuration and pan-and-tilt camera designed for mainline and larger pipeline applications up to 500 feet. It integrates video observation coding, observation coding interface and digital recording into an easy-to-use package. This lightweight system includes large and durable wheels for portability and a balanced footprint for stability. It is manufactured to handle rigorous field use. 800/327-7791; [www.cuesinc.com](http://www.cuesinc.com).



### ENVIROSIGHT VERISIGHT PRO

The **VeriSight Pro** from **Envirosight** has a stainless self-leveling camera with shadowless, variable LED illumination that captures crisp video footage regardless of pipe material. With supplied centering devices, it inspects lines 2 to 9 inches and snakes through multiple bends for maximum range. An integral tri-band sonde (33 kHz, 512 Hz, 640 Hz) works with almost any locator. Its welded steel coiler comes with 130, 200 or 330 feet of pushrod. The entire system runs continuously for six hours off internal rechargeable lithium-ion batteries or off main or vehicle power. Its multilanguage controller displays footage on an 8-inch TFT LCD and captures up to 90 hours of MPEG 4 video on an SD/SDHC card or USB stick. It lets the user zoom 3X, captures images in JPEG format from both live and recorded video, and offers a 16-page text writer with full QWERTY keyboard. **866/936-8476; www.envirosight.com.**



### FORBEST PRODUCTS CO. FB-PIC3688M

The **FB-PIC3688M** long-range pipe inspection camera from **Forbest Products Co.** has a dock for a digital monitor and optional 360-/180-degree camera. It comes with 400 feet of 9-mm fiberglass cable on a reel with a meter counter. The stainless steel frame carries a dock for placing the 10-inch LCD monitor for convenient operation and transportation. Camera head options include a 1 1/2-inch, self-leveling color camera head or 2 1/4-inch, waterproof, 360-/180-degree pan-and-tilt, high-resolution color camera head with zoom for panoramic pictures. The heavy-duty multifunction waterproof control box includes a 10-inch LCD color screen with USB and built-in SD card to record photos and videos. Users can type and edit on the screen with the installed keyboard. Control buttons on the front panel are designed for remote camera head rotation for over 20,000 hours continuously. **877/369-1199; www.forbestusa.net.**

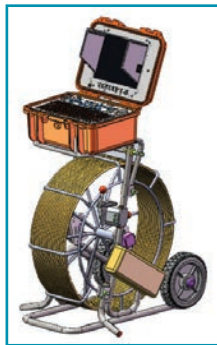

### HATHORN CORPORATION MAGNUM M7

The **Magnum M7** from **Hathorn Corporation** is packed with multiple features and is extremely lightweight at only 29 pounds. The unit can easily be carried down a flight of stairs or rolled on its 6-inch wheels. The 7.4-inch monitor delivers a clear, bright picture and is covered by an acrylic shield for durability. It offers USB recording, 2-hour lithium battery, on-screen footage counter, 512 Hz sonde transmitter, adjustable lighting and text writer. A Wi-Fi transmitter can be added for recording to a mobile device. It comes with a variety of pushrod lengths and camera sizes to fit every job type. **905/604-7040; www.hathorncorp.com.**



### INSIGHT VISION CAMERAS OPTICAM 2017

The **Opticam 2017** camera system from **Insight Vision Cameras** has a user-friendly keypad that's been redesigned with an easy on-demand recording and snapshot button to help speed up inspection time. Technicians can easily record vital inspection data and client information using the available on-screen text writer and footage counter. A built-in microphone and speaker allows the technician to record voice-over videos and then play the video back on the 10.4-inch LCD monitor. The system includes a 1.3-inch modular, self-leveling camera head that is geared to inspect sewer pipes from 3 to 12 inches in diameter. A built-in sonde broadcasts a 512 Hz frequency that is locatable with a 512 Hz locator. The system comes with a free downloadable Insight Vision app for iOS and Android mobile devices that allows users to view, record, snapshot and share sewer inspection videos. **800/488-8177; www.insightvisioncameras.com.**



### MEDIT MINIFLEX

The **MiniFlex** plumbing camera from **MEDIT** is designed for small-diameter pipe inspections by plumbers, pool and spa professionals, and pipe fitters. The 0.76-inch-diameter camera will make straight runs in pipes 0.8 inch and larger while the flexible neck allows the unit to navigate bends and traps in pipes 1.25 inches in diameter or larger. It is a self-contained set with a cassette tape design that houses the push cable on the reel around the outside, a 5.6-inch color LCD screen in the middle to view live inspections, a memory card to capture image and video, text generation, video output, an on-screen foot counter, a built in 512 Hz sonde to locate the camera head underground or behind walls, LED lights, a rechargeable battery, and lengths from 49 to 98 feet. **800/239-9934; www.fiberscope.net.**



### MYTANA MANUFACTURING MS11-NG2

The **MS11-NG2** midsize inspection system from **MyTana Manufacturing** has USB for recording and storage. The system is suitable for inspecting 3- to 6-inch lines with the choice of 150 or 200 feet of pushrod. The unit has a 64 GB internal drive as well as two onboard USB ports and a 32 GB removable USB drive. The one-piece design is lightweight with a carrying handle. The color camera head is self-leveling with a built-in 512 Hz transmitter for locating trouble spots, even in cast iron pipes. **800/328-8170; www.mytana.com.**



### R.S. TECHNICAL SERVICES INC. (RST) QUICK PEEK

The **Quick Peek** all-in-one, fully portable video inspection system from **RST** is a compact, lightweight solution for drainline condition assessment in lines 2 to 10 inches in diameter up to 300 feet in length. The unit includes a 7-inch, bright, LCD, handle-mounted monitor equipped with a sun shield/screen protector that can be positioned for a comfortable viewing angle. Easily accessible monitor controls include power mode; aspect ratio (screen size); menu; and set buttons for color, brightness, contrast, tint and volume. The side-mounted AC/DC power source houses controls

for all camera functions and provides a camera test terminal, AC/DC input, video/audio output, keyboard input and a condenser microphone with an on/off switch. It has a high-resolution, low-lux color camera; AC/DC input; keyboard for annotation; video/audio output; microphone; and is fully locatable with 512 Hz in-line transmitter. 800/767-1974; [www.rstechserv.com](http://www.rstechserv.com).

### RAPIDVIEW IBAK NORTH AMERICA MINILITE PUSHROD SYSTEM

The **MiniLite Pushrod System** from **Rapid-View IBAK North America** is a compact and versatile platform for inspection of small-diameter pipelines. The system works with HYDRUS, JUNO, NANO, NANO-L, ORION Zoom, ORION-L and POLARIS cameras. It has a bright, 10-inch touch screen and a built-in Windows PC with power supplied by an 18-volt rechargeable battery. The multifunction joystick allows precise control of the pan-and-tilt camera. 800/656-4225; [www.rapidview.com](http://www.rapidview.com).



### RATECH ELECTRONICS ELITE USB WITH WI-FI

The **Elite USB with Wi-Fi** from **Ratech Electronics** lets users record pipe inspections directly to a USB flash drive and wirelessly via an app to an iOS or Android device while taking live video and digital still photos, which can be immediately uploaded to YouTube. The Wi-Fi interface is available on any current or existing Ratech Electronics systems in the field. It's available with a sun-readable, 10-inch LCD monitor and a self-leveling camera, ultramicro camera or pan-and-tilt push camera. Systems come in cable lengths from 100 to 400 feet. 800/461-9200; [www.ratech-electronics.com](http://www.ratech-electronics.com).

### RAUSCHUSA MINCAM360

The 2-inch, **minCam360**, remote-controlled, pan-and-tilt push camera from **RauschUSA** has digital zoom and a tri-band sonde with selectable frequencies. The Bluetooth remote includes a joystick for camera control. The cable reel



is equipped with 200 feet of cable (with up to 300 feet available), and the removable batteries run for four hours. Its RID steering skid enables it to push into 45-degree Y and 90-degree T branches in the pipe. The 8.4-inch, sun-light-readable monitor enables recording video, voice and photo directly to an SD card. This system is designed as a capable stand-alone inspection system, including a text generator for detailed reporting capabilities and an on-screen distance counter. Applications range from 3- to 20-inch pipe diameters with all centering accessories. 717/709-1005; [www.rauschusa.com](http://www.rauschusa.com).



### SPARTAN TOOL EXPLORER

The **Explorer** modular camera system from **Spartan Tool** has a control box that is compatible with five different pushrods 5 to 14 mm in diameter and 130 to 400 feet in length. Up to nine hours of battery life lets the user complete multiple jobs without recharging. The open-reel design allows for easy cleaning, and the stainless steel camera heads provide for extra durability. USB, SD and cloud storage is available. It comes with WinCan software pre-installed, allowing the user to map entire plumbing systems. The screen allows the user to see it clearly, even in direct sunlight. 800/435-3866; [www.spartantool.com](http://www.spartantool.com).



### VIVAX-METROTECH CORP. VCAMMX

The **vCamMX** from **Vivax-Metrotech Corp.** is a portable, all-in-one camera to inspect pipes between 1 and 4 inches. The control module's 8-inch daylight-viewable LCD screen shows the distance of pushrod deployed as well as the current time and date. Recordings are made in AVI video and photos are made in JPG format directly to a USB flash drive and then instantly backed up to an SD card. An internal microphone allows audio commentary over recorded video. The pushrod is traceable with the use of an external locator transmitter and is available in 100 or 150 feet. The dual-frequency 512 Hz/33 kHz sonde is standard equipment. Two interchangeable camera heads can be switched out by the user in the field. The smaller D18-MX camera is fixed-position and 0.7 inch in diameter, and the D26-MX is self-leveling and 1 inch in diameter. 800/446-3392; [www.vivax-metrotech.com](http://www.vivax-metrotech.com).

## WOHLER USA VIS 350 PLUS WITH LOCATOR

The **VIS 350 Plus** visual inspection system from **Wohler USA** allows users to precisely locate pipe damage and document the results of the inspection. Its 1.5-inch camera head can pan 360 degrees and tilt 180 degrees. Users can inspect waterlines 2 inches and larger with the pan-and-tilt feature to ensure no damage is overlooked. The camera head has an integrated transmitter that facilitates location detection with a Wohler L 200 locator, which has an easy-to-read color display. Users can record video footage and store photos on a 4 GB SD card for documentation and archiving purposes. 978/750-9876; [www.wohlerusa.com](http://www.wohlerusa.com).



## CAM SPRAY TT4025HZ-350

The model **TT4025HZ-350** trailer jetter from **Cam Spray** produces 25 gpm at 4,000 psi using a U.S. EPA Tier 4 final Hatz Diesel 74 hp turbo intercooled, liquid-cooled engine. It comes with an over-center clutch, control panel with hour meter, low-fuel gauge, low-fuel shutdown, over-pressure shutdown and digital pressure readout. The reel is hydraulic powered with variable speed and comes mounted on a slide-out with angle adjustment fitted with 500 feet of 5/8-inch hose, manual shut-off valve and analog pressure gauge. RCM wireless remote control modes include valve open, valve close, engine idle down with a 15-second time delay shutdown, emergency shut-off, two-speed engine rpm control and auxiliary 10-amp circuit with on/off control. 800/648-5011; [www.camspray.com](http://www.camspray.com).

## TRUCK/TRAILER JETTERS

### AMAZING MACHINERY BOSSJET PRO BOX JETTER

The **BossJet Pro Box Jetter** from **Amazing Machinery** can be mounted in many configurations. It comes with a Honda or Kohler engine, a triplex plunger pump and a Hannay Reels electric hose reel. All units are encased in a high-density aluminum box frame with an access panel on the side for exhaust release and ease of service. It comes with 200 feet of 1/4-inch I.D. jetter hose and laser and spin jet nozzles. It is designed to clean and clear 2- to 6-inch pipes. Options include a foot pedal, a trap kit, a remote reel and porta-potty head attachment for the smaller lines. All units include a washdown gun and wand, four pressure washer tips, and a chemical injector for easy clean-up. 800/504-7435; [www.amazingmachinery.com](http://www.amazingmachinery.com).

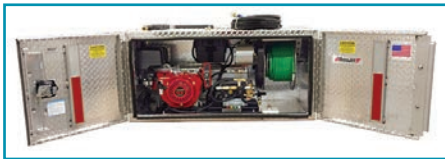

### MONGOOSE JETTERS BY SEWER EQUIPMENT MODEL 184

The **Model 184** jetter from **Mongoose Jetters by Sewer Equipment** has a tubular steel frame, corrosion-resistant prepainted subassemblies, state-of-the-art controls, a strong hose reel, high-quality diesel engine and the Mongoose Run Dry Pump. 877/735-4640; [www.mongoosejetters.com](http://www.mongoosejetters.com).



### PIPEHUNTER 45418

The **PipeHunter 45418** trailer jet has a 400-gallon poly tank and heavy-duty, urethane-coated frame. The 4,000 psi at 18 gpm water system can be upgraded to 25 gpm if needed. The 50 hp Cat diesel engine is powerful enough to drive the Giant water pump. Its hydraulic, articulating reel and base lets operators set up however they need to for the job. The reel also has a capacity up to 800 feet of 1/2-inch hose. 800/373-1318; [www.pipehunter.com](http://www.pipehunter.com).



### AMERICAN JETTER 51T SERIES HOT JETTER

The **51T Series Hot Jetter** from **American Jetter** offers up to 74 hp of hot-water cleaning power and flows from 8 to 24 gpm up to 4,000 psi. Dual or triple diesel burners offer maximum water heating capability.

Consistent power is provided by a 37 hp Kohler gas engine. A dual-engine option provides 74 hp. Low-water shut-off prevents pump damage if the 330-gallon tank runs low. Standard hose reel-speed control allows for precise cleaning in both directions. The wireless remote option allows for water on/off, engine shutdown and hose reel control. The heavy-duty square tubing trailer offers standard electric brakes on both axles. 866/944-3569; [www.americanjetter.com](http://www.americanjetter.com).

### SUPER PRODUCTS SUPERJET

The **SuperJet** truck-mounted jetter from **Super Products** has a double-acting, single-piston, hydraulically powered water pump that offers a 1-1 oil-to-water ratio and rated design capacity of 100 gpm and 3,000 psi continuous duty. Its modular water tank setup easily accommodates capacities from 1,000 to 3,200 gallons. It has a single-engine design that emits lower sound levels, reducing fuel use by 40 percent compared to dual-engine units. Its rear compartment is heated with an 80,000 Btu/h heater that enables year-round operation in freezing environments. An easy-to-use control panel performs a number of functions including adjustable engine throttle with water pressure speed dial, on/off water pump PTO, water pressure and gallons per minute, and hose reel joystick as well as pay-in/pay-out with speed control. 262/796-5939; [www.superproductslc.com](http://www.superproductslc.com).



**VACTOR MANUFACTURING  
RAMJET 850 SERIES**

The Vactor Manufacturing Ram-Jet 850 Series truck jetter has a choice of front or rear hose reel locations and productivity-enhancing options such as an aluminum rear shroud and optional JetRodder water pump-heated cabinet. An integral aluminum rear shroud with heavy-duty, see-through Lexan windows is available. Large service access doors on both sides of the shroud enable easy greasing, maintenance and service. The rear shroud keeps the hose and components warm and protected in cold conditions. It comes with a certified flow of 0 to 80 gpm at a variable pressure up to 2,500 psi. Park-N-Clean technology allows the operator to park near the manhole and, with minimal setup time, start cleaning. 800/627-3171; [www.vactor.com](http://www.vactor.com).



**VACUUM TRUCK/PUMP/ACCESSORY**



**WESTMOOR LTD. CONDE HD**

Conde HD vacuum/pressure pumps from Westmoor Ltd. are built in a variety of sizes from 35 to 230 cfm. They incorporate the Conde Slide Valve, or changeover valve, which is compact, low-profile and works easily. Automatic oilers never need adjustment.

The pumps can be driven by a variety of power sources, including a gas or diesel engine package, PTO, right-angle drive or hydraulic pump. They are double shafted and can easily be set up for either clockwise or counterclockwise rotation. Accessories and protection packages are available to help protect the pump/vacuum system. 800/367-0972; [www.westmoorltd.com](http://www.westmoorltd.com). **c**

**digDIFFERENT** magazine

Exclusively serving contractors involved in alternative excavation that goes beyond buckets and blades [www.digdifferent.com](http://www.digdifferent.com)

**GET  
EMAIL NEWS  
ALERTS FOR  
Cleaner**  
 Go to  
[cleaner.com/alerts](http://cleaner.com/alerts)  
 and get started today!

**DO YOU HAVE A  
HOSE OR FITTINGS PROBLEM?  
WE HAVE THE SOLUTION.**

*Burning through yards of hose every day?  
Using duct tape to patch or connect hose?*

Call us to discuss your application and we will match it to the most suitable hose and fittings. Using duct tape is both inefficient and a safety hazard. We can make up hose assemblies with all types of fittings and connectors.

Don't be the duct tape guy.

**We have the solution.**



**12 SITES AND GROWING.  
\$10 MILLION PARTS IN STOCK**

**PARTS • REPAIRS • MAINTENANCE  
SALES • RENTALS • TRAINING**

**WHATEVER THE PROBLEM, WE HAVE THE SOLUTION**



**OEM GUZZLER VACTOR JETSTREAM CONSUMABLES AND  
ACCESSORIES AVAILABLE FOR ALL MAKES**



**WWW.FSSOLUTIONSGROUP.COM • 800.822.8786**

©2017 FS Solutions Group



## LIVE DEMOS AT THE WWETT SHOW

Want to see how a piece of equipment works? The WWETT Show is the place to go for live demonstrations. Hammerhead, I.S.T. Services, Picote Solutions and others are having demos in the Marketplace Expo Hall, perfect for getting up-close and hands-on. Or join companies that include Gradall, Nozzteq, and Vector as they show off the heavy equipment at WWETT Live! at Lucas Oil Stadium.

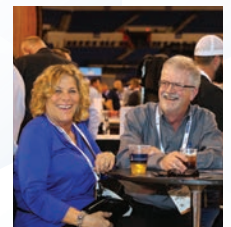
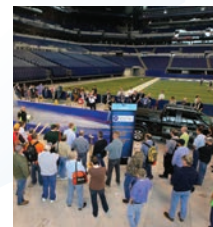

**wwett<sup>™</sup>18**

EDUCATION: FEBRUARY 21-23  
EXHIBITS: FEBRUARY 22-24  
INDIANA CONVENTION CENTER

### WHY SHOULD YOU ATTEND?

- ✓ **Explore the Marketplace** for tools and resources you need for your business
- ✓ **Education** taught by some of the best and brightest in the industry
- ✓ **Events** to network with your peers - or just kick back with friends.

REGISTER TODAY AT [WWW.WWETTSHOW.COM](http://WWW.WWETTSHOW.COM)



## Business Diversification – Septic Pumping, Plumbing

By Craig Mandli

### CONTRACTOR USES CUTTING TOOL TO CLEAN CONSTRUCTION DEBRIS

#### PROBLEM

Sylvan Tieger offers a full range of plumbing and drain cleaning services to commercial, residential and institutional customers in the New York City area. Much of that is new construction. Tieger noticed that construction debris — like plaster and cement powder — often deposited in drainlines. He needed a way to easily clear those drainlines.

#### SOLUTION

Tieger tried the ClogChopper cutting tool from General Pipe Cleaners. With six self-sharpening blades, the ClogChopper digs into encrusted debris and root masses, easily grinding up stoppages, scale and crystallized urine without risking pipe damage. It works in both directions — all in one operation.

The spherical design maneuvers around tight bends and traps, thoroughly and safely cleaning metal, plastic and clay pipes. Available in 1-, 1 1/2-, 2-, 2 1/2-, 3- and 4-inch sizes, it can be used to clear stacks, downspouts and mains — as well as for pipe lining jobs.



#### RESULT

“You quickly get a buildup of hardened material inside pipe walls,” says Tieger. “ClogChopper makes short work of those problems.”  
800/245-6200; [www.drainbrain.com](http://www.drainbrain.com). c



Join over 9,400 of your colleagues who already get great content delivered right to their inbox with the Cleaner e-newsletter.

[www.cleaner.com/newsletter](http://www.cleaner.com/newsletter)

**DO YOU HAVE AN EQUIPMENT PROBLEM? WE HAVE THE SOLUTION.**

Is your vacuum truck not performing as it should? Are you using more and more fuel to get the same production? A full 360° inspection and quote from us may help find the solution.

On site or at our facility call us to arrange your 360° inspection today.

Performance problem?

**We have the solution.**



**12 SITES AND GROWING.  
\$10 MILLION PARTS IN STOCK**

**PARTS • REPAIRS • MAINTENANCE  
SALES • RENTALS • TRAINING**  
**WHATEVER THE PROBLEM, WE HAVE THE SOLUTION**



OEM GUZZLER VACTOR JETSTREAM CONSUMABLES AND ACCESSORIES AVAILABLE FOR ALL MAKES



[WWW.FSSOLUTIONSGROUP.COM](http://WWW.FSSOLUTIONSGROUP.COM) • 800.822.8786

©2017 FS Solutions Group

## PRODUCT SPOTLIGHT

# Water recycling keeps sewer cleaners on the job

By Craig Mandli

In sewer cleaning, time is money. Companies using traditional combination sewer cleaners typically have to stop cleaning several times a day to fill up the freshwater reservoir to continue jetting. That not only interrupts the job, it means added fuel costs in addition to the cost of the water.

There is another option, though. The Triton combination sewer cleaner from Supervac has a water recycling system that employs a Juggler filter system to allow continuous work without downtime for water filling. It filters water collected in the debris tank and transfers it to a water reservoir used by the Pratisoli water pump. According to Steeve Sheehy, Supervac's national sales manager, units in the field are already providing dividends for users.

"We have a unit right now in the field that is being used all week with the same water," he says. "There's no downtime because there's no need to refill it with freshwater."

The filtration system separates the liquid from the solids. The solids are returned to the reservoir, and water is fed into the water tank and can be reused to supply the pressure pump of the scrubber. The self-cleaning filtration system removes up to 80 percent of the liquid from the debris, providing additional savings in dumping costs.



"When you dump the debris, it is actually debris, not water," Sheehy says. "With dumping costs at an all-time high in North America, that can lead to a huge savings as well."

The unit comes with a 2,500-gallon debris tank with stainless steel liner and vibrator, 1,500-gallon water tank, hydraulic boom and dump, and a full-opening rear door. Vacuum is provided by a 3,800 cfm at 27 inches Hg Robuschi USA blower, while jetting power is provided by an 80 gpm/2,500 psi Pratisoli water pump specifically designed for recycled water. The rear- or front-mounted hydraulic hose reel holds 600 feet of 1-inch hose.

"Grease isn't going to bog down this machine because it is self-cleaning," Sheehy says. "We designed it so that it can be used to clean grease traps. We only suggest that you give the filter a rinse once a week."

When the savings in water, fuel and work time are combined, Sheehy believes the system can pay for itself in short order.

"We calculate that using a Triton system in a municipal environment will save upward of \$100,000 per year," he says. "When you work for a city and are trying to save every tax dollar you can, that's huge." 866/839-5702; [www.supervac2000.com](http://www.supervac2000.com).



1

### 1 WATER CANNON INC. - MWBE NONMARKING PRESSURE WASHER HOSE

The durable double-wire stainless-steel-wrapped nonmarking pressure washer hose from Water Cannon Inc. - MWBE has a 4-1 safety factor and has a working pressure of 8,000 psi with burst strength of 32,000 psi. The gray polyurethane cover does not leave marks on the surface. 800/333-9274; [www.watercannon.com](http://www.watercannon.com).



2

### 2 STONEAGE PRODRAIN PRO-700 DRAIN CLEANER

The ProDrain PRO-700 accessory from StoneAge for the AutoBox ABX-PRO tackles drain cleaning jobs. It does not require tethering. If a system becomes unsteady, an integrated circuit dumps the water to ensure operator safety. The protective splash plate is weighted for stability, and a hose guide tube directs the tool to ensure precise jetting. 866/795-1586; [www.stoneagetools.com](http://www.stoneagetools.com).





3



4

### 3 CAT PUMPS PLUNGER PUMP MODEL 67070

The Model 67070 high-pressure plunger pump from Cat Pumps is ideal for sewer jetting and hydroexcavating market applications requiring high-flow performance at higher pressures and intermittent duty operation. It is rated at 50 gpm at 2,000 psi. The drive-end of the pump is built from the 60-frame mechanical drive, and oversized, premium crankshaft bearings offer high loading capacity that prolongs bearing life. The crankcase crosshead area is concentric with a 360-degree plunger rod support, featuring a drilled-through oil port to lubricate the front side of the crosshead area. 763/780-5440; [www.catpumps.com](http://www.catpumps.com).

### 4 RIDGID CABLE CUTTERS

RIDGID's new line of lightweight, ergonomically designed cable cutters includes three ratcheting and two manual cutters for copper and aluminum cutting needs. Ratcheting cutters range in weight from 1.5 to 6.4 pounds, have maximum copper capacity ranging from 600 to 1,000 mcm, and maximum aluminum capacity ranging from 750 to 1,000 mcm. An enclosed spring is protected from debris and loss during use. Manual cutters range in weight from 1.5 to 3.3 pounds and have maximum capacity for both aluminum and copper ranging from 500 to 1,000 mcm. Each features a sickle-shaped, rounded blade for precise cutting. 800/769-7743; [www.ridgid.com](http://www.ridgid.com). c

**DO YOU HAVE A  
TRAINING PROBLEM?  
WE HAVE THE SOLUTION.**

*Finding it difficult to get experienced help?  
Have the man power but need to increase  
the skill level?*

Call us to arrange training for your team to enable them to **maximize your investment** in the equipment you own. Training programs can include operation and maintenance of equipment, OSHA safety issues, application specifics, tech tips and best practices.

You **invested millions** in equipment, **invest** in getting operators to run it efficiently. Call us and, we will build a training program to fit your organization. **We have the solution.**



**12 SITES AND GROWING.  
\$10 MILLION PARTS IN STOCK**

**PARTS • REPAIRS • MAINTENANCE  
SALES • RENTALS • TRAINING**  
**WHATEVER THE PROBLEM, WE HAVE THE SOLUTION**



**OEM GUZZLER VACTOR JETSTREAM CONSUMABLES AND  
ACCESSORIES AVAILABLE FOR ALL MAKES**



**WWW.FSSOLUTIONSGROUP.COM • 800.822.8786**

©2017 FS Solutions Group

Searching  
for More?

More news at  
[Cleaner.com/featured](http://Cleaner.com/featured)

**Cleaner**

# KEN-WAY Beats the Others DAY-IN • DAY-OUT

And they have for over 50 years

## KEN-WAY CABLE CLEANERS

for cleaning sewer, drain or process lines  
from one to ten inches, up to 75 feet  
with the Junior and up to  
a full length of 300 feet  
with the Model 400

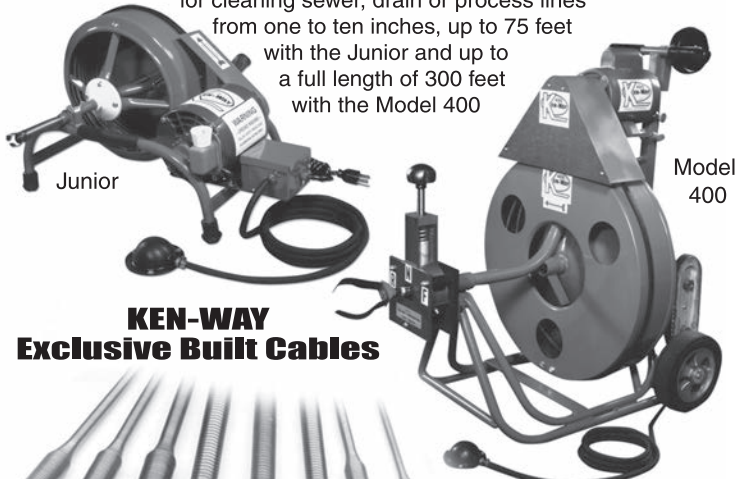

## KEN-WAY Exclusive Built Cables

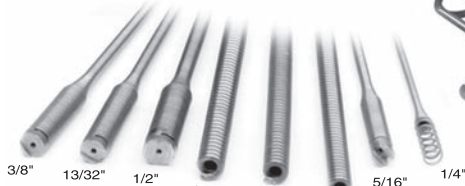

- Heat Treated
- Inner-Core or Non-Core
- Fit Most Other Brands
- Interchangeable with Most Brands
- Coupling or Blade Holding Types



Leasing plans available. Call for details.  
**1-800-533-0551**

930 ROBERTS ROAD, SPARTA, WI 54656  
www.ken-way.com • E-mail: info@ken-way.com

## INDUSTRY NEWS

### Kyle Warren joins Sprayroq

Sprayroq announced the addition of Kyle Warren to its corporate team as operations assistant. He will be responsible for the technical and customer service side of the operations team. Warren has his master's and bachelor's degrees from the University of Alabama, and he is in the process of completing his welding certification.



Kyle Warren

### Envirosight releases new poster for sewer workers

A new, free poster from Envirosight illustrates how sewer workers can protect themselves from workplace biohazards using personal protective equipment, developing proper hygiene habits and cleanup practices, and obtaining recommended vaccinations. Working in and around sewage increases the risk of disease and infection, so workers must take extra precautions to protect themselves and their families.

### JWC Environmental receives Water Environment Federation Innovative Technology Award

JWC Environmental was awarded the Innovative Technology Award by WEF for its Wipes Ready technologies. The grinder technology, available exclusively on the company's Muffin Monster and Channel Monster products, helps combat the problems caused by disposable wipes. **C**

## Petersen® Pipe Plugging Systems



Pipe Plugs and Packers for all your Pressure, Chemical, and Temperature Requirements. Call us to quickly customize a pipe plug or plugging system for your specific application.

### Economical Hot Tap Plugging Systems

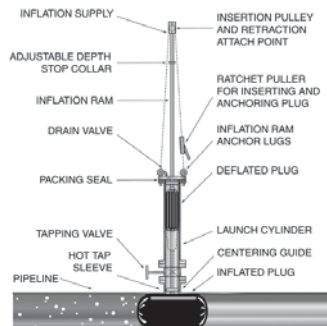

[www.pipeplug.com](http://www.pipeplug.com)

**Petersen** PRODUCTS COMPANY  
Serving Professionals Since 1916

PHONE 800.769.4973 OR 262.692.2416  
FAX 800.669.1434 OR 262.692.2418



COLEpublishing

Keeping it GREEN since 1979

[www.colepublishing.com](http://www.colepublishing.com)



**24 HOUR TURNAROUND - MIDWEST'S LARGEST FACTORY AUTHORIZED  
REPAIR CENTER FOR GEN-EYE, GATORCAM & SEESNAKE**

## ClogChopper™

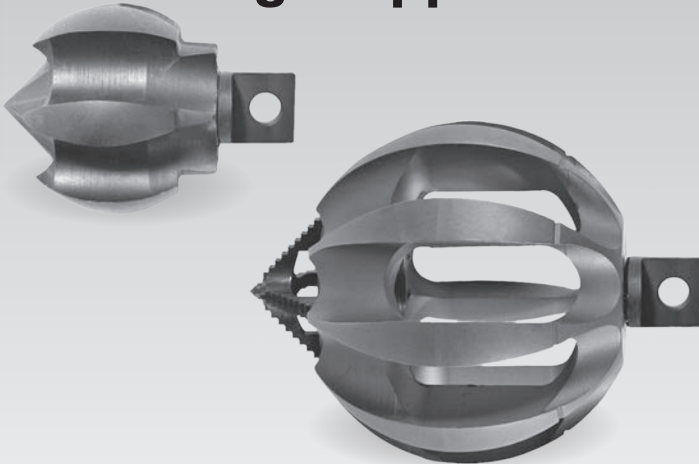

- Multi-function cutting tools
- Six self-sharpening blades
- Risk-free pipe damage
- Maneuvers around tight bends
- Safe cleaning on metal, plastic and clay pipes
- Variety of sizes
- Connector options for most drain cleaning machines

**CALL FOR PRICING!**

## NEW Gen-Eye Hot Spot™ Pipe Locator



- Easy to read display – Icons lead you to your target and auto backlight lets you locate in dimly lit areas.
- Total field antenna array – Allows you locate from any direction.
- Line direction compass – Tells you the lay of the pipe.
- Industry's most rugged locator – Rated IP65, the industry's highest, it is dust and dirt proof and water resistant.
- Superior Battery Life – Batteries lasts twice as long as other brands.
- Expanded Frequencies – Locates two sonde frequencies, two power frequencies and four line frequencies.
- Upgradeable Software – Use the USB port to upgrade software in the field.

**CALL FOR PRICING!**



**General J-2900**  
Basic Unit Machine Only

**\$2745**  
FREE DELIVERY

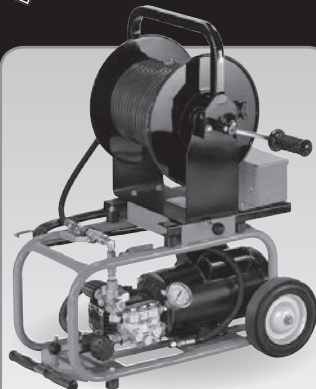

**General J-1450**  
**Portable Jetter**  
Basic Unit Machine Only

**\$1540**  
FREE DELIVERY



**Mini-Rooter XP™**  
Basic Unit – No cable cutters  
or power feed

**\$580**  
FREE DELIVERY



**General Speedroooter 92™**  
Basic Unit – No cable cutters  
or power feed

**\$1160**  
FREE DELIVERY

**FREE FREIGHT ON ALL CAMERA KITS**



**Internal Pipe Coating System**

- Sets in seconds, not hours or days like epoxy
- Coats from 100 mil to 300 mils in one pass
- Structural



▶ Watch A Video Of This Process

877-507-0861 • PipeTechUSA.com

Over 30 years building quality equipment!

**HotJetusa®**

**OUR MOST VERSATILE JETTER!**  
FULLY LOADED! PRICE INCLUDES DELIVERY!\*

**HOTJET II**  
WITH PAYMENTS AS LOW AS **\$565.00**  
\*\$2,995<sup>MS</sup> SALE PRICE WITH 20% DOWN O.A.C.

35 HP Vanguard Engine • 10GPM @ 4,000 PSI  
Cleans 2-12" Drains with Hot OR Cold Water  
\*Delivery to lower 48 States Only - CALL FOR DETAILS

**1-800-213-3272**  
[www.hotjetusa.com](http://www.hotjetusa.com)

**ERICKSON**  
Tank & Pump

**509.785.2955**  
CALL FOR UPDATED LIST OF EQUIPMENT

[WWW.ERICKSONTANK.COM](http://WWW.ERICKSONTANK.COM)

**Masport®**  
PUMPS & QUALITY COMPONENTS

Quincy, WA  
fax: 509.785.3770  
sales@ericksontank.com  
"TANKS" FOR YOUR BUSINESS!

**WE TAKE TRADES**

**THE "ORIGINAL" LIQUID SMOKE**

**Turbo Fog M45:**

- Versatile
- Light Weight
- Compact
- Creates Dense Smoke

**TURBO-FOG®**  
Since 1977

[www.turbo-fog.com](http://www.turbo-fog.com) • 1-800-394-0678

**Show us your Money Machine.**

Do you have a go-to service vehicle or high-tech workhorse tool that conquers many jobsite challenges? Let us know about it at [editor@cleanermag.com](mailto:editor@cleanermag.com) and we'll consider it in our feature.

*Ere tra! Ere tra!*

*Want More Stories?*

Get more news,  
more information,  
more features with  
**Online Exclusives**

Exclusive online content  
for *Cleaner*

[www.Cleaner.com/online\\_exclusives](http://www.Cleaner.com/online_exclusives)



**All In!**

When you receive **Cleaner** each month there is **no need to bluff**. Join 25,000 of your industry peers each month who welcome **Cleaner**, for the unlimited value it brings them. Each issue will show you new tools, tips to save on expenses, money-saving deals and much more.

**800.994.7990**  
**www.cleaner.com**

Subscribe today to guarantee your winning hand!

Join A National Brand: [www.RooterMan.com](http://www.RooterMan.com)

**ROOTER-MAN**  
 "To The Rescue"  
 NO ROYALTY ON PERCENTAGE OF SALES  
 Franchise Package \$3,975

RESERVE YOUR EXCLUSIVE TERRITORY • Call 1-800-700-8062

**CONFINED SPACE ENTRY PACKAGE ONLY \$3,195**

- 4-Gas Air Monitor (3 Year Sensor Warranty)
- 7' Tripod
- 3-Way Fall Protection
- Work Winch
- Full Body Harness

Add a Blower with 15' of duct for only \$350!  
 Add a 5 Minute Escape Respirator for only \$500!

**MTECH** 800.362.0240  
[www.mtechcompany.com](http://www.mtechcompany.com)

Let Us Build Your **JETTER**

**Diesel Propane Gas**

**AMERICAN JETTER.COM**  
 866-944-3569

**DR DYNAMIC REPAIRS**

**We Repair:**  
 General Wire, Ratch, RIDGID, Hathorn Corp.  
 Electric Eel, GatorCams, Vision Intruders  
 and Vivax Inspection Cameras,  
 Locators, Command Modules and Cables

**New & Refurbished Inspection Equipment For Sale**  
**Rental Equipment Available**  
 Daily & Weekly Rates

**Ask About Our 48-Hr. Turn Around Time**

**INSPECTION CAMERAS ARE OUR ONLY BUSINESS!**

**973-478-0893**  
**DYNAMIC REPAIRS**  
 40 Arnot St., Unit 20  
 Lodi, NJ 07644  
[dynamiccablerepairs@yahoo.com](mailto:dynamiccablerepairs@yahoo.com)  
[www.dynamicrepairs.biz](http://www.dynamicrepairs.biz)

**Advertise Advertise Advertise Advertise SOLD**

Reach over 26,000 professionals each month and sell your equipment in the classified section.

**COLE publishing**  
[www.Cleaner.com](http://www.Cleaner.com)

**OceanQuip LLC**  
 ORCA TOUGH CABLES

Let us help you get connected!

PO Box 3333  
 Harvey, LA • 70059  
 Phone: 504.738.7833  
 Fax: 888.979.8195  
[ruth.hoth@oceanquipconnectors.com](mailto:ruth.hoth@oceanquipconnectors.com)  
[www.oceanquipconnectors.com](http://www.oceanquipconnectors.com)

**DYE TRACERS**

Solutions for:

- Infiltration
- Septic Systems
- Cross Connection
- Leaks and more...

**BRIGHT DYES**  
 Division of Kingscote Chemicals

**www.brightdyes.com • 1-800-394-0678**

**EXPLORE OUR OTHER OPTIONS**

Find us at: **Cleaner.com**

- NEW EQUIPMENT
- CLEANER BUYER'S GUIDE
- ARTICLES: Current and Past Issues, Online Editorial, Editor's Blog
- CLASSIFIEDS
- INTERACT: E-Zines, E-Newsletters and Discussion Forums
- And more.

WANT MORE CLEANER?  
 LIKE US FOLLOW US  
 YouTube VIEW US

**OBLITERATE ROOTS**

**OBLITIROOT**  
 SEWER LINE FOAMING ROOT KILLER

Up to 3x the active ingredient

[www.olvidium.com](http://www.olvidium.com) (877) 477-5338

**Every day is Earth Day™**

"When we have a large rain storm there is so much infiltration into the sewer system, sewage treatment plants can be flooded. And if this overflows into the bay you have a problem. There are huge fines for dumping sewage into the bay, and a lot of cities have been going through inspecting and even doing grants for homeowners to upgrade their sewers."

**Denis O'Halloran**  
 An Original Environmentalist  
 President, Southwood Plumbing & Heating, San Bruno, Calif.

**Southwood Plumbing Heating**

**Cleaner**

**COLE publishing cleaner.com • 800.257.7222**  
 Proudly Serving the Environmental Service Industry Since 1979

**T&T Tools, Inc.**  
**800.521.6893**

CALL for a FREE Catalog  
 Many styles Available

**Insulated Soil Probes (for locating)**  
**Heat-Treated Hooks (for covers, lids, etc)**

**www.mightyprobe.com**

## BLOWERS

**New Roots Blowers** - Best price & in stock. Reconditioned exchange program. Volume discounts. Call Pat's Pump & Blower 800-359-7867 or email PatsPump@aol.com (C01)

## BUSINESSES

**www.RooterMan.com.** Franchises available with low flat fee. New concept. Visit website or call **1-800-700-8062.** (CBM)

## COMPUTER SOFTWARE

FreeServiceReminderSoftware.com, FreeServiceDispatchSoftware.com, FreeRouteManagementSoftware.com. (C12)

WinCan v8 License (WANTED) - USB stick - Must be mobile (field) version. v8 or newer only. Call 407-702-7266. (C12)

## DRAIN/SEWER CLEANING EQUIPMENT



**1996 Isuzu FRR** diesel, 236,987 miles, a/c, 6 new tires, new auto. transmission. 14 ft. all-aluminum box with hydraulic liftgate. Jetter is a Sewer Equipment of America 14gpm @ 4,000psi. Myers water pump, only 10 hrs since rebuild. 80hp Perkins diesel motor with only 900 hrs. since complete rebuild. 300-gallon poly water tank, 600 ft. of 1/2" hose, hydraulic reel. In great shape and ready to go to work. Can drive anywhere. In top condition. Email for additional photos. \$26,000

**ronsrooter@yahoo.com**  
Call **270-554-3711**  
or **270-556-4275**

(C12)

Used and rebuilt cable machines in stock: RIDGID K-7500, K-40, K-60, K-1500, Spartan #1064, #300, #100, Electric Eel model #C machines. The Cable Center: 800-257-7209. (CBM)

Jet trailer & rodding machine for sale: 1996 Aquatech SJE Series Sewer Jet, 35gpm @ 2,000psi, 600' of 3/4" jet hose, 1,842 hours, complete maintenance log. \$11,500. 2005 Sreco continuous rodder, 15 hours in service. \$14,500. Both units in great condition. Information/pictures, contact Monty @ 801-207-9728; monty@dawsonis.com (C12)



**1999 SRECO** Flexible Hy-Velocity trailer jet machine. 2,000psi, 40gpm, Model L0614SC. 750-gallon water tank, 500 ft. capability, new 3/4" hose. Machine runs great. Motivated seller. .... \$7,000

Contact **561-582-9292** C12  
or **allproplumbing1@gmail.com**

## HYDROEXCAVATING EQUIPMENT



**2013 Kenworth T800 Vactor** hydro-excavator for sale. 20gpm, 27" blower, 12-yd. debris tank, 79,000 miles, 6,900 hrs., 2,800 blower hours. .... \$285,000

**Dave 916-442-5400, CA** C01



**2016 Vac-Con X4212-1300** Hydro-excavator. 8' x 8" telescoping boom, 20gpm/4,000psi Hydrox system, BTE diesel-fired boiler, LED lighting package, high-pressure 72" Hydro X Lance, additional tool boxes, chassis warranty. Chassis engine hrs.: 630; Chassis mileage: 1,617. Call Richard Davey for pricing or if you have any questions.

**803-609-9140, SC** C12

**Cleaner**  
AVERAGE MONTHLY  
CIRCULATION REACHES  
**26,460 READERS!**

## JET VACS



**2004 Sterling LT7500 Safe Jet Vac 1015:** 3126 CAT engine, Allison auto. transmission. Safe Jet serial # T1259Y 154010TCJ03. New Meyers DP80-20 water pump hydraulic-driven, wash-down gun & reel 50' x 1/2" Karcher 5,000psi @ 5gpm gas Honda-powered for hydro-excavating. 15" Hibon blower, wireless pendant, newer paint & newer tires. 236k miles, 15,850 engine hours. .... \$80,000

Contact **Kris 253-856-2572**  
**kris@pcsjac.com** C12



**2015 Vac-Con 4212LHAEG-1300** Freightliner 114SD chassis 12-yard, dual engine, Ford gas V10 sewer combination truck. 80gpm @ 3,000psi, 10' telescoping boom, Roots 827PD blower, Giant water pump. Hydroexcavation package, debris body flush out, industrial hydraulic rear door, LED lighting package. Aux. engine hours: 1126.30. Chassis mileage 11,020. Call Richard Davey for pricing or if you have any questions.

**803-609-9140, SC** C12



**Vac-Con** industrial machine mounted on a pre-owned 2006 Sterling cab and chassis. \$59,000. (Stock #8593C)

**www.VacuumSalesInc.com**  
**(888) VAC-UNIT (822-8648)** CBM

2007 Sterling Vactor 2100PD tandem-axle combination cleaning truck. Ex-city owned, well maintained, and equipped with California Carb Compliant DPF System. See details of this unit and other cleaning and CCTV inspection units at [www.empireequip.com](http://www.empireequip.com). Contact Craig at 714-639-8352. (CBM)



**2007 VACALL ALLJET VAC AJV1015** Combo. Sterling LT7501 chassis CAT C-7 330hp, Allison 3000 RDS, 171,853 miles, 11,250 hours. OMSI TC, 80gpm General MSS55, Roots 824, 10-cubic-yard debris tank and 1,500-gallon water tank. .... \$85,000 OBO

Call **Mark for more information**  
**708-475-7116, IL** CBM

2010 Vac-Con model V311LHRA/1300 combination machine. 60gpm/3,000psi water pump, JD 125 hp. aux. engine (973 hours), 11-yard, 10' telescopic boom. 2010 IH 7500 6x4, 350hp, Allison 3000RDS auto. transmission, 20,143 miles, 2,544 hours. Ex-city unit, great condition. Please call for pricing 800-294-0149 or visit [www.williamseqpt.com](http://www.williamseqpt.com). (C12)

## JETTERS-TRAILER



**The Industry's Most Versatile Trailer Jetter** Model# HJ2TA1030HW, tandem axle trailer, 35hp Vanguard 10gpm @ 3,850psi, 325-gallon water tank, 300' hose, General Pump. **Fully loaded!** List \$36,995. On sale for \$32,995.

**800-213-3272**  
**www.hotjetusa.com** CBM



**2006 US Jetting 4018:** 300-gallon water, 18gpm @ 4,000psi, Hatz Diesel silent pack. Work-ready unit. ...\$14,900

**800-627-0788** C12

Jetter components, truck and trailer. Pumps: Aquatech, FMC, Myers, Vactor. Reels Hydraulic systems. Diesel and gas motors. Hoses 3/4" and 1". Culvert and root cutter nozzles. You build or we build. 734-365-4035 (C12)



**2005 John Bean Sewer Jet**, 600-gallon tank, 500' 3/4" hose on hydraulic reel, fuel injected 4 cyl. gas engine, 194 original hours, Bean pump, 40gpm/2,000psi. Very nice, Ready to work. .... \$14,000

**Call 219-863-4414, IN** C12  
or [buschbrosinc@gmail.com](mailto:buschbrosinc@gmail.com)

2016 Mongoose 184, CAT diesel, 1/2 and 3/8 Warthogs, Full remote. Unit is in mint condition, used very little. Paid \$52,000 new. Asking \$41,500. Call/text 423-525-2978. (C12)

1995 US Jetting 4017 trailer style. 1,911 total hours. Hatz silent pack diesel runs strong w/o issue. Harben P pump w/jump jet & full antifreeze cold-weather use system. Has swivel/sliding reel and just under 1,000 ft. of jetting hose on it. This has been a rock-solid unit and needs a little work consisting of either a handle rebuild on engagement valve or valve replacement. There are 2 exterior brass nuts to replace on P pump that are leaking and robbing pressure. The pump had all new internal check valves installed w/ less than 100 hrs. Great unit. \$8,900 OBO. Has title. Email for pics/info: [bish4@att.net](mailto:bish4@att.net); 636-346-4822 (C12)

2007 SRECO flexible hydro jetter. 600-gallon tank, hydraulic reel, 500' 3/4" hose, rotating reel, 200' 3/8" hose, nozzles. FMC Bean pump, 40gpm/3,000psi. Ford gas motor. \$19,500. 805-797-0241 (C12)

1997 Harben 300-gallon trailer jetter. 4,000psi Hatz diesel, 786 hours. New hose. Extremely nice unit. \$19,500. Call 574-401-3496. (C12)

2006 Sewer Equipment of America 747-FR2000: 1,462.1 hours. New pump at 1,214 hours 40gpm/2,000psi. \$25,000. More info visit [www.mahoneyequipment.com](http://www.mahoneyequipment.com) or call 636-282-4949 (C12)

4016 Harben: Reconditioned with 125 hours. (2) 300-gallon tanks, new 4-wheel trailer. Runs great. \$20,000. Call Mike at 765-427-7575. (C12)

## JETTERS-TRUCK

1993 Ford F800 diesel automatic, 18,000 miles, 2,000-gallon stainless steel, Perkins 6 cyl. diesel. Myers 65-20 pump, 600' of 1" hose, nozzles & accessories. Ex-city unit. \$20,990 OBO. 734-365-4035 for pictures and more info. (C12)

Harben 600-gallon jetter truck. 4,000psi @ 25gpm, 2002 Isuzu NQR, 20,081 miles. New hose. Extremely nice unit. \$42,500. Call 574-401-3496. (C12)

2005 Chevy Kodiak with Harben jetter. Call 315-882-1858. Follow the link for the local ad: <https://syracuse.craigslist.org/hvo/d/chevy-kodiak-with-jetter/6351369738.html?lang=en&cc=us> (C12)

Jack Doheny Supplies Inc. offers a full range of late model combo units and DOT industrial vacuum loaders. Call us @1-800-3DOHENY. (CBM)

## LOCATORS

Used RIDGID Navitrack, Gen-Eye Model 100 and Goldak Model 4400. The Cable Center 800-257-7209. (CBM)

## PIPELINE REHABILITATION



**2011 Aries TV, test/seal and lateral grouting unit**, fully equipped and ready to go to work! Heavy-duty, offroad, diesel-powered 2011 International 7500 Series 6x6 with 22' US truck body. Mileage: 66,700. Mainline and lateral grouting, 2 TV reels, 700 feet of grout hose, 20kw industrial generator, 70-gallon, heated, twin grout tanks, 220-gallon water tank (heated). Truck was built for all-season work and traveling with extra amenities for production and storage. Has had only one operator since manufactured. Please contact Frank or pricing and additional details.

**440-585-5757 ext. 2, OH** C12  
[lscs@lakecountysewer.com](mailto:lscs@lakecountysewer.com)

## POSITIONS AVAILABLE

GapVax, Inc., a nationally recognized manufacturing business, is seeking a talented, highly motivated individual to fill a full-time Sales Position in the Midwest (Iowa based preferred) region. GapVax is the leading manufacturer of industrial and municipal vacuum units and hydroexcavation units in the United States. We provide the most reliable, comprehensive, and efficient mobile vacuum units in the industrial and municipal markets. Specifications of the position are listed on our website, [www.gapvax.com](http://www.gapvax.com), click on the Now Hiring link in the left hand column. Send resumes to or [betty@gapvax.com](mailto:betty@gapvax.com) or 575 Central Avenue, Johnstown, PA 15902. (CBM)

Experienced Jet-Vac Operator wanted - Tampa, FL based company. Mostly local work. Competitive pay. Email [Apply@BestUtilityJobs.com](mailto:Apply@BestUtilityJobs.com) (C12)

## PUMPS

Honda model WP40X, 8 hp, 4" with hoses. Honda 4 hp, 2" pump with hoses. The Cable Center: 800-257-7209. (CBM)

## RENTAL EQUIPMENT

Liquid vacs, wet/dry industrial vacs, combination jetter/vacs, vacuum street sweeper & catch basin cleaner, truck & trailer mounted jetters. All available for daily, weekly, monthly, and yearly rentals. **VSI Rentals, LLC, (888) VAC-UNIT (822-8648) www.vsirentalsllc.com.** (CBM)

## RODDING MACHINES

SRECO Rodder Machine. Engine was running last year. Has some rod already in machine. 1987. \$3,000 OBO. Mike 704-635-1334 (C01)

## SERVICE/REPAIR

**Dynamic Repairs - Inspection Camera Repairs:** 48 hour turn-around time. General Wire, Ratech, RIDGID, Electric Eel Mfg, Gator Cams, Insight Vision, Vision Intruders. Quality service on all brands. **Rental equipment available.** For more info call Jack at 973-478-0893. Lodi, New Jersey. [www.dynamicrepairs.biz](http://www.dynamicrepairs.biz) (CBM)

## TRAILERS

2014 Doosan P-250 WJD T4i air compressor. Like-new, 105 hrs. Loaded with all the options, including additional Y outlet (4 total), block heater, line oiler, fuel strainer. Original list \$25,000. \$21,000 OBO. Call Brad 508-404-6648. Boston area. (C12)

## TOOLS

**T&T Tools:** Probes, hooks. Probes feature steel shafts with threaded and hardened tips. The insulated **Mighty Probe™** tested to 50,000 volts. **Top Poppers™** open manhole covers easily. Free catalog. **www.TandTtools.com.** Phone **800-521-6893.** (CBM)

Bosch Brute hammer drill with cart irons. The Cable Center: 800-257-7209. (CBM)

RIDGID model #300 with stand, RIDGID tri-stand vises, RP 330 ProPress kit. The Cable Center: 800-257-7209. (CBM)

**Submit your classified ad online!**  
[www.cleaner.com/classifieds/place\\_ad](http://www.cleaner.com/classifieds/place_ad)

## TV INSPECTION



**1997 GMC 3500 Savanna UEMSI TV** inspection truck. 5.7 gas engine, 88,961 miles, UEMSI PCU, Dell PC with Windows operating system. .... \$10,000 OBO

**Call Mark for more information**  
**708-475-7116, IL** CBM



**2002 Ford E450 16' UEMSI TV** inspection truck. V10 gas engine, 122,798 miles, UEMSI PCU, Dell PC with Windows operating system. .... \$12,000 OBO

**Call Mark for more information**  
**708-475-7116, IL** CBM

**LOOKING FOR TRACTION IN THAT GREASY PIPE??** Finally – a flexible polymer wheel with carbide grit for added traction in all pipe types and conditions, fitting most major CCTV transporter brands. Patent pending. Order today at [trugrittraction.com](http://trugrittraction.com), call 407-900-1091 or email [info@trugrittraction.com](mailto:info@trugrittraction.com) (CBM)

Used SeeSnake Camera Systems in all sizes; Used General Wire Spring Camera Systems in all sizes; Used machines in all sizes. We want your trade! The Cable Center: 800-257-7209. (CBM)

PEARPOINT — Mainliner buying & selling used equipment. Canada & USA PEARPOINT MAINLINE EQUIPMENT ONLY. Will buy complete Pearpoint trucks. Will buy your old system. Do you need parts? 399, 599 reels; 420, 448 tractors: 494 digital and zoom 420 light heads. Call 800-265-4298 or [mainliner2075@hotmail.com](mailto:mainliner2075@hotmail.com) (CBM)

Used and rebuilt camera kits in stock: RIDGID Mini Compact, Mini Color, Standard Self-Leveling, General Gen-Eye I, II and III, Aries Seeker, and SRECO kits. The Cable Center: 800-257-7209. (CBM)

## TV INSPECTION

**NEED TRACTION?** We make aftermarket more aggressive pads and chain assemblies for all chain-driven camera tractors. Custom, dependable, double-hole fabrication secured to high-quality carbon steel chain, or just pads and rivets. Also available: non-gritted pads. Samples upon request. **Pipe Tool Specialties LLC:** 888-390-6794; Fax 888-390-6670; [www.yourtractionpads.com](http://www.yourtractionpads.com) or email [pts4422@yahoo.com](mailto:pts4422@yahoo.com) (CBM)

## VACUUM EQUIPMENT



**2016 Vac-Con 5816SM** industrial truck. Top-mounted 8" boom with 180-deg. hydraulic rotation, material return system (automatic), debri tank vibrator, wireless remote. Engine hrs.: 125.8. Chassis mileage: 3,712. Call Richard Davey for pricing or if you have any questions.

**803-609-9140, SC** C12

## VACUUM LOADERS

**1999 International Guzzler** vacuum excavator: Totally refurbished, purchased new for Big Dig Project. 27" blower, CAT engine, auto remote. Special noise-suppression equipment. Tri-axle. High-pressure wash-down system - 300-gallon water tank. \$79,500 OBO. Also available **1997 Ford Guzzler** vacuum excavator - same features as 1999 International. No washdown system. \$79,500 OBO. Call 617-212-0162. (CBM)

**Submit your classified ad online!**  
[www.cleaner.com/classifieds/place\\_ad](http://www.cleaner.com/classifieds/place_ad)

## WANTED

Wanted to Buy: Vactor 2100s and late model Guzzlers. Cash. 800-336-4369. (CBM)

## WATERBLASTING



**Aquadyne - Blastmax 125 UHP** water blaster. Rated for 40k @ 4.25gpm. 100hp Deutz D914L06 six-cylinder, air-cooled diesel engine. Road-ready trailer mounted w/tandem axle. Low hours. \$55,000. Ready to operate. Setup includes, 50' hose and (1) 40k dump gun w/self-rotating head. Contact us for other packages.

**Rodney 772-215-3062, FL**  
[rodney@alljetting.com](mailto:rodney@alljetting.com) C12

20,000 - 55,000 psi Sapphire Nozzles, OS4, OS6, OS7 replacements, UHP hoses & replacement parts. Excellent quality & prices. 772-286-1218, [info@alljetting.com](mailto:info@alljetting.com), [www.alljetting.com](http://www.alljetting.com). (CBM)

**For Sale:** Two (2) Myers M1610K40 - pumps only. [www.waterjettingequipment.com](http://www.waterjettingequipment.com) or phone 714-259-7700. (CBM)

**Cleaner**  
AVERAGE MONTHLY  
CIRCULATION REACHES  
**26,460**  
READERS!

# SOLD

## Sell your equipment in *Cleaner* classifieds

Reach over 26,000 potential buyers each month when you list your equipment in the classified section. Plus, your listing is placed automatically online at the *Cleaner* website. In addition, your ad will be placed in the *Pumper e-Trader*, an electronic magazine that is e-mailed to readers. That's three ways to move your equipment out of the yard!

## Why wait?

Go to  
[Cleaner.com/classifieds/place\\_ad](http://Cleaner.com/classifieds/place_ad)



Scan the code with your smartphone.

## Follow Cleaner on



[www.facebook.com/CleanerMag](http://www.facebook.com/CleanerMag)



[twitter.com/CleanerMagazine](http://twitter.com/CleanerMagazine)





# INDUSTRY MARKETPLACE

With 600 exhibitors and 350,000 sf of exhibit space, the WWETT Show is the Marketplace for the wastewater and environmental services industry. See the new product launches, get hands-on with equipment, and make your purchases. The WWETT Show Marketplace is WHERE DEALS GET DONE



**wwett 18**  
 EDUCATION: FEBRUARY 21-23  
 EXHIBITS: FEBRUARY 22-24  
 INDIANA CONVENTION CENTER

## WHY SHOULD YOU ATTEND?

- ✓ **Explore the Marketplace** for tools and resources you need for your business
- ✓ **Education** taught by some of the best and brightest in the industry
- ✓ **Events** to network with your peers - or just kick back with friends.

REGISTER TODAY AT [WWW.WWETTSHOW.COM](http://WWW.WWETTSHOW.COM)





**35**  
CELEBRATING YEARS OF SERVICE

# Pressure Washers, Replacement Engines Pumps, Parts & Accessories

WaterCannon.com

1.800.333.WASH (9274)

**HONDA  
GX  
SERIES**



**VERTICAL  
AXIAL  
PUMPS**



**PUMPS WITH BUILT-IN UNLOADER & INJECTOR**



**HORIZONTAL TRIPLEX**

**3/4"**



**HORIZONTAL  
AXIAL  
PUMPS**



**GAS FLANGE HOLLOW SHAFT PUMPS**



**1"**  
Contractor  
Duty



**DIRECT MOUNT  
UNLOADER  
CONTROL  
SETS**



**ELECTRIC FLANGE HOLLOW SHAFT PUMPS**



**TRAPPED PRESSURE  
UNLOADER VALVES**



**DIRECT MOUNT UNLOADER  
CONTROL SETS**



**SOLID SHAFT PUMPS**



**FLOW SENSITIVE  
UNLOADERS**



**PUMP MOUNTED  
UNLOADERS WITH EXTERNAL  
BYPASS**



**SAFETY PRESSURE RELIEF  
(POP-OFF) VALVES**



**INDUSTRIAL UNLOADER  
VALVES & REGULATORS**



**THERMAL  
RELIEF VALVES**



**EASY START  
VALVES**



**JETTER  
VALVES**



**Industry Trained Staff** available from 8:30 a.m. to 6:00 p.m. weekdays E.S.T.

Water Cannon, Un contacto en Espanol: llama al: 1.800.917.9274

Orlando | Phoenix | Minneapolis | Hattiesburg | Melbourne | Toronto | Bogota  
International: 1-321-800-5763

**Water Cannon**  
is proud to be a  
**MWBE**

# GapVax

Manufacturer of custom-built  
Industrial Vacuum Equipment,  
Air Movers, Combination JetVacs,  
Water Recycling JetVacs, Hydro Excavators,  
skid-mounted vac units, parts & accessories  
and more!

HEADQUARTERS  
888-442-7829  
TEXAS LOCATION  
281-884-8658

*Merry  
Christmas  
from all of us,  
to all of you*

Give yourself the gift of

# POWER PERFORMANCE

**vwett18**  
Feb 21-24, 2018  
*See you in Indy!*

   [www.gapvax.com](http://www.gapvax.com)



# SPARTAN

ANDY PASSON, DIMICK SEWER SERVICE, JOLIET, IL



URBAN WARRIOR

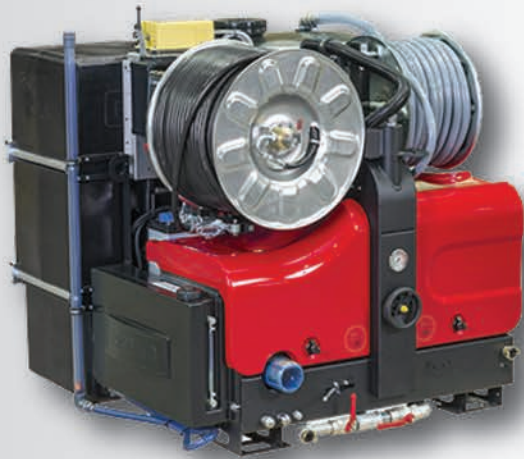

SPARTAN CABLE



MODEL 300



PROFESSIONAL  
GRADE.  
FOR TOUGH  
CUSTOMERS.

SPARTANTOOL.COM | 800.435.3866