

Cleaner

FOR DRAIN AND PIPE CLEANING, INSPECTION AND REHABILITATION PROFESSIONALS

www.cleaner.com | AUGUST 2013

Doing the JOB RIGHT

TIGHT SEAL PLUMBING TAKES A PERSONAL
APPROACH TO BUILDING ITS BUSINESS **PAGE 38**

**WATERBLASTING AND WATERJET
CLEANING AND ACCESSORIES**

MONEY MACHINES
Cart-mounted jetter opens new markets

TECH PERSPECTIVE
Run a better inspection program

TOUGH JOB
CIP lining solves a restaurant's problems

TAKE CLOGGED DRAINS BY STORM



Typhoon™ gives you big cleaning power.

General's Typhoon™ trailer jet blows away blockages in big lines and long runs. 12 gallons of water storm down the drain at a powerful 2500 psi to blast lines clear of grease, sediment, ice, and debris.



Patented high performance nozzles increase cleaning power without increasing water flow or pressure.

Guide hose easily into line with retractable guide arm. Clear grease, sand, and ice in 4" to 12" lines.



- Durable 690 cc Honda engine powers the 2500 psi, 12 gpm pump with Vibra-pulse®.
- Secure 200 gallon holding tank carries enough water to handle remote applications where water is limited.
- 400 ft. capacity jet hose reel with electric rewind and variable speed controller.
- Key engine controls, including hour meter, mounted in lockable tool box with slide action doors.
- Easily maneuverable, heavy-duty trailer with splash guard to protect pump and engine from road debris.
- Standard safety equipment: Electric brakes, safety strobe light, rear fold down stabilizer jacks, retractable guide arm, and anti-freeze system.
- Patented, high performance nozzles for significantly increase thrust, pulling power, and cleaning power without increasing water flow or pressure.

General
PIPE CLEANERS
www.drainbrain.com

For more information, contact the Drain Brains®
at 800-245-6200 or 412-771-6300 or visit
www.drainbrain.com/jets



MADE IN USA

The toughest tools down the line.™

© General Wire Spring 2013





Who's in Charge of Evolution?

The Vac-Con Combination Machine has evolved from many years of experience ... the customer's experience! If you want to know what works ... or not, ask the guy who spends his days at the end of a vacuum hose trying to do a good job.



Scan the QR code to view a combination machine product demonstration.

Contact us Today!
888.491.5762 or
go to **www.vac-con.com**

We will listen because you make the evolution for better machines.

A HOLDEN INDUSTRIES Company



NEW FOR 2013 TR130

3-D TANK & VESSEL CLEANING

KEY FEATURES

- All external parts are now machined and bolt together. No welded body parts.
- All external parts are now sealed with a captive o-ring between machined surfaces.
- Improved seal design protects gearing and internal components from water intrusion
- The number of weep holes have been increased from 4 to 12 total. Weep locations have also been relocated to easily identify a worn seal.
- Both high-pressure seals are accessible by removing only 4 cap screws.
- Synthetic 5W-20 oil is now used to lubricate the brake rather than conventional ATF—decreasing temperatures and improving brake life.



BIGGER ISN'T ALWAYS BETTER

The new **TORUS TR130** is over **20% SMALLER** than its predecessor. Allowing much greater accessibility to smaller tank openings.

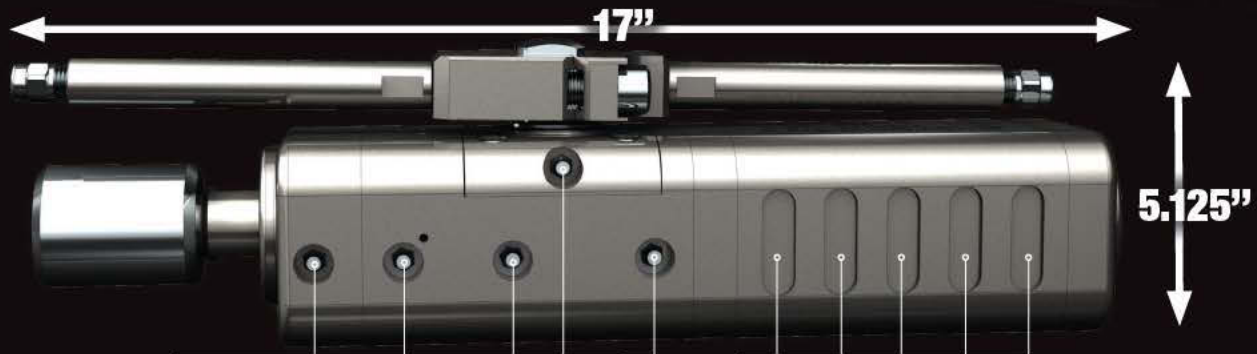

ALL GREASE FITTINGS ARE DIRECTLY ACCESSIBLE

MACHINED RECESSES KEEP THE TOOL RUNNING COOLER

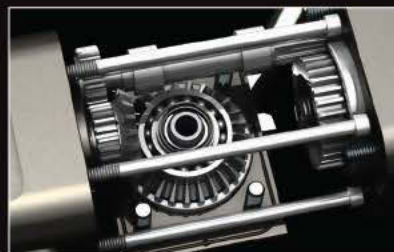
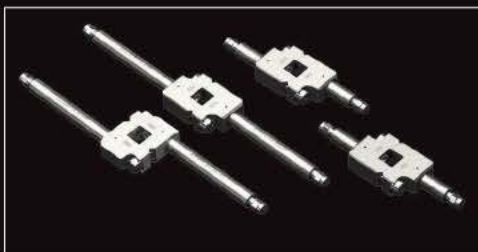

MAXIMUM FLEXIBILITY - ONE TOOL DOES IT ALL

Four inlet couplings and four bolt-on manifolds allow for quick and easy adaptation to different pumps, working pressures and cleaning applications. Interchangeable stainless steel nipple extensions allow maximum jet power and debris removal by placing the nozzles close to the target surface.

INTELLI-TORQ GEARING

If the arms hit an obstruction, the tool simply stops rotating so there are no broken gears to repair. The result is longer tool life and less maintenance.

OCV CARBIDE NOZZLES

The highest quality, longest lasting nozzles available ensure excellent jetting results and hours of trouble-free operation.



GET THE INDUSTRY'S MOST EFFECTIVE
3-D TANK CLEANING TOOLS

1-866-795-1586 • WWW.STONEAGETOOLS.COM

underground understood

TM



crawl

ROVER X records digital video, generates reports, and links to asset software. It adapts in seconds to inspect any size pipe, and is based on digital architecture that lets you monitor onboard sensors, automate tasks, and measure pipe features. ROVER X supports side-scanning, laser profiling and other innovative technologies, and automatically updates its firmware to always offer the latest features.



push

VeriSight Pro lets you inspect pipe, document findings, and create reports for on-site delivery. It captures detailed footage under punishing conditions, and accepts USB and SD media for easy transfer of data, video, images and reports.



zoom

QuickView surveys pipes and manholes from street level. With it, a city can assess an entire collection system to identify and prioritize maintenance needs, and a contractor can accurately bid and document services.



share

WinCan delivers the intelligence needed to make key maintenance decisions. It supports new technologies like GIS integration, virtual 3D, side scanning and laser profiling, as well as popular defect catalogs like PACP and WRc.

Envirosight



www.envirosight.com • 973.252.6700

©2013 EnviroSight, LLC. All rights reserved. The EnviroSight, ROVER X, QuickView and VeriSight names and logos are registered trademarks of EnviroSight. Underground Understood is a trademark of EnviroSight. The WinCan name and logo are trademarks of CD-Lab and used under license. QuickView carries patents 6,538,732 and 7,009,692; others pending.

worldwide sales, support and service

features

38 Profile: Doing the Job Right
By Marian Bond



On the cover: Tight Seal Plumbing owner Daniel Baker stands on the rooftop of an 18-story building in Chattanooga, Tenn., while crew member Danzel Owens sets up for an inspection. Tight Seal has been in business since 2004 and specializes in drain cleaning, jetting, CCTV inspection, plumbing service and repair. (Photos by Dan Reynolds)

16 Profile: Born Again
North American Pipeline Services delves deeper into public projects to expand its business and restore the shore.
By Erik Gunn

58 Waterblasting/Waterjet Directory

departments

10 From the Editor: Different Sizes of Success
The drain cleaning industry presents opportunities for anyone who does good work and treats people fairly.
By Luke Laggis

54 Safety First: The Cost of Excavation Safety
Taking the proper precautions is the best thing for your employees and your company's bottom line.
By Doug Day

12 Editor's Choice

64 Tough Job: Made to Order
Cured-in-place lining solves a restaurant's backup problems overnight while protecting a historic Victorian mansion.
By Scottie Dayton

26 Money Machines: Brute Force
Cart-mounted water jetter opens up a new market for Illinois drain cleaner while improving productivity and profits.
By Ken Wysocky

70 Money Manager: Saving For a Rainy Day
Ample liquid cash reserves help you weather inevitable fiscal storms and emerge with your profitability and long-term business plan in tact.
By Erik Gunn

32 Expo Spotlight: Freedom waterblaster built for the cold
By Ed Wodalski

74 Product Focus: Waterblasting and Waterjet Cleaning and Accessories
By Craig Mandli

46 Better Business: No-Suit Solutions
Mediation provides a private, low-cost option for resolving business disputes.
By Fred S. Steingold

84 Industry News

48 Tech Perspective: Make More Money
Establishing a successful CCTV inspection program takes careful planning, attention to detail and plenty of hard work.
By Jim Aanderud

86 Product News
Spotlight: Root killer prevents intrusion
By Ed Wodalski

COMING IN SEPTEMBER

ISSUE FOCUS:
Mainline Sewer Inspection

- > Tough Job: CIPP solves school's odor problem
- > Money Manager: Insure your human assets
- > Profile: Sewer Duck thrives on diversification
- > Profile: Syracuse drain cleaners celebrate 125 years

Get Social with Cleaner



- facebook.com/CleanerMag
- twitter.com/CleanerMagazine
- plus.google.com
- youtube.com/CleanerMagazine

Cleaner

FOR DRAIN AND PIPE CLEANING, INSPECTION AND REHABILITATION PROFESSIONALS

www.cleaner.com

Published monthly by:

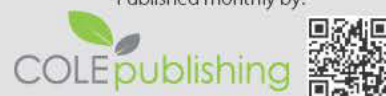

1720 Maple Lake Dam Rd. • PO Box 220
Three Lakes, WI 54562

© Copyright 2013 COLE Publishing Inc.
No part may be reproduced without permission of the publisher.

In U.S. or Canada call Toll-free 800-257-7222
Elsewhere call 715-546-3346
Email: info@cleaner.com Web: www.cleaner.com
Fax: 715-546-3786

Office hours Mon- Fri, 7:30 a.m.-5 p.m. Central Time

SUBSCRIPTION INFORMATION: A one year (12 Issue) subscription to *Cleaner* in the United States or Canada is free to qualified subscribers. A qualified subscriber is any individual or company in the United States or Canada that is involved in the inspection, cleaning, repair and installation of residential and commercial sewer lines. Non-qualified subscriptions are available at a cost of \$60 per year in the United States and Canada/Mexico. Subscriptions to all other foreign countries cost \$80 per year. To qualify, visit www.cleaner.com/order/subscription or call 800-257-7222.

Our subscriber list is occasionally made available to carefully selected companies whose products or services may be of interest to you. Your privacy is important to us. If you prefer not to be a part of these lists, please contact Nicole at nicole@colepublishing.com.

CLASSIFIED ADVERTISING: RATE: No Photo Classified \$25 for 20 words, each additional word \$1. All classified advertising must be PAID IN ADVANCE. DEADLINE: Classifieds must be received by the first of the month for insertion in the next month's edition. PHONE-IN ADS ARE NOT ACCEPTED. Ads may be faxed only when charging to MasterCard, VISA, Amex or Discover. Please supply all credit card information with faxed ads. Be sure to include your phone number (with area code) in your ad. Make checks payable to COLE Publishing Inc. and mail with classified ad to the address above. CLASSIFIED ADVERTISING APPEARS NATIONWIDE AND ON THE INTERNET. Not responsible for errors beyond first insertion.

DISPLAY ADVERTISING: Contact one of our sales staff below at 800-994-7990. Publisher reserves the right to reject advertising which in its opinion is misleading, unfair or incompatible with the character of the publication.



Kayla Bisnette Jim Koshuta

REPRINTS AND BACK ISSUES: Visit www.cleaner.com for options and pricing. To order reprints, call Jeff Lane at 800-257-7222 (715-546-3346) or email jeff@colepublishing.com. To order back issues, call Nicole at 800-257-7222 (715-546-3346) or email nicole@colepublishing.com.

CIRCULATION: Circulation averages 27,338 copies per month. This figure includes both U.S. and international distribution.



PUMPER & CLEANER ENVIRONMENTAL EXPO INTERNATIONAL

Education Day: February 24, 2014
Exhibits Open: February 25 - 27, 2014
Indiana Convention Center
www.pumpershow.com

The Emerson logo is a trademark and service mark of Emerson Electric Co. ©2013, RIDGID, Inc.

INTEGRATED TRANSPORT SYSTEM – Includes handle and strap for easy transport around job sites.

DOCKABLE MONITOR SYSTEM – Works with RIDGID® cM6 and CS6 Inspection Monitors.

DURABLE REEL CASE – Built RIDGID® tough to take day-to-day abuse.

STOW BIN – Convenient storage for tools and essentials.

1-INCH SELF-LEVELING CAMERA HEAD – Easily navigates small diameter lines.

Already purchased an rM200? Get a FREE upgraded camera head at RIDGID.com/RM200



ACTUAL SIZE

SELF-LEVELING

MAX VERSATILITY

SeeSnake® *MAX* rM200 CAMERA SYSTEM

EASILY EXAMINE 1.5 TO 6-INCH LINES WITH A CAMERA THAT OFFERS A CONSISTENT, UPRIGHT VIEW.

★ REQUEST A FREE ONSITE DEMO ★ RIDGID.COM/RM200 | 1.800.769.7743

We Build Reputations™

RIDGID

EMERSON
Commercial & Residential Solutions

August 2013
Advertiser Index

A

Allan J. Coleman Co. 23, 73

 Amazing Machinery, Inc. 65

 Aqua Mole Technologies, Inc. 87

 Aries Industries, Inc. 15

B

 Bandlock Corp. 82

 Bowman Tool Co. & Systems 82

C

 Cable Center, The 56, 85

 Cam Spray 62

 Central Oklahoma Winnelson 44

 Chempure Products Corp. 72

CIPP Services, LLC 50

CIPP Technology & Equipment LLC 36

 Coast Manufacturing 68

Coxreels 67

 CUES 55

D

 Drainables Direct 28

 Duracable Manufacturing Co. 11

E

 Easy Liner (Gadmon Industries) 90, 91

 Electric Eel Mfg. 62

 Envirosight, LLC 5

 Enz USA, Inc. 14

F

 F. S. Solutions 25

Flow-Liner Systems, Ltd. 53

Forbest Products Co. 52

G

 GapVax, Inc. 95

 Gardner Denver Waterjetting Systems 19

 General Pipe Cleaners/General Wire Spring ... 2

Giant Industries, Inc. 24

 Gorlitz Sewer & Drain, Inc. 37

 Guzzler Manufacturing, Inc. 63

H

Hammelmann Corp. 29

 Hannay Reels 41

Harben, Inc. 33

 Hi-Vac Corporation 21

J

 Jetstream of Houston 77

Jetter Depot 71

JETTERS NORTHWEST 67

K

 Ken-Way Corporation 82

L

LADTECH, Inc. 50

LaPlace Equipment Co. 68

M

 Mid-Atlantic Waste Systems 71

MRP

Milwaukee Rubber Products 62

 Mylana Mfg. Company, Inc. 51

N

 NLB Corp. 28, 43

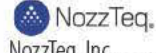
 NozzTeq, Inc. 34

O

 Oceanquip, LLC 68

 Ovidium, Inc. 10

P

 Perma-Liner Industries, LLC 9

Petersen Products Co. 71

Pipeline Renewal Technologies 27

 PipeLogix, Inc. 72

Piranha Hose Products 54

 PrimeLine Products, Inc. 30

 Pulsar 2000, Inc. 83

R

Radiodetection Corporation 30

 RapidView IBAK North America 69

 Ratech Electronics, Ltd. 24

 Reelcraft Industries, Inc. 12

RIDGID

RIDGID 7, 47

Ring Power/Cat Rental Store 14

 RS Technical Services, Inc. 67

RYCOM Instruments, Inc. 36

S

 Safety Corporation of America 50

 Scooter Video 79

 Southland Tool Mfg., Inc. 35

 Spartan Tool, LLC 96

SPIR STAR 50

 StoneAge, Inc. 4

 Super Products, LLC 57

T

 T&T Tools, Inc. 56

 TRYTEK Machine Works, Inc. 67

 TSE International 36

TST Sweden AB 83

U

 US Jetting, LLC 13

V

 Vac-Con, Inc. 3

 Vacall - Gradall Industries 45

 Vivax-Metrotech Corp. 34

VSI Rentals 52

W

Westmoor Ltd. 44

WJTA-IMCA 31

Woma Corporation 34

Marketplace 88

Classifieds 90

THE 40-Minute Cure!

Is Your Crew Installing And Curing Liners In 40-Minutes?

If you're not,
it's time to become more
profitable with Perma-Liner's
cutting edge technology.
Call Today For Your Cure.

PERMA-LATERAL™ LINING

The #1 selling small
diameter pipe lining system
in North America!

We Provide:
Marketing Support Programs
Re-Training Support Classes
Certification Training Classes
24/7 Technical Support
Lead Generation Program
Exclusive Patented Technology

Supplies:



DANCUTTER®
WORKING SOLUTIONS

Exclusive Distributor for North America
Sales & Service



See Us Live! ... Denver: August 14TH ★ Updated Location Louisville: September 18TH

Read about Grant Utilities and Perma-Liner in the Tough Job article pg 64.

★ **Denver** ★
Trenchless Pipelining Seminar
FREE Registration

Speak One-On-One
Watch Live Demos



PERMA-LINER™
INDUSTRIES, LLC.

ZERO DIG TRENCHLESS PIPE REPAIR

1-866-336-2568 Toll Free
1-727-507-9749 Int'l
www.perma-liner.com



Luke Laggis
editor@cleaner.com

Different Sizes of Success

THE DRAIN CLEANING INDUSTRY PRESENTS OPPORTUNITIES FOR ANYONE WHO DOES GOOD WORK AND TREATS PEOPLE FAIRLY

BY LUKE LAGGIS

Some people dream of building a big company and dominating their industry. Others simply want to be in business for themselves, doing the work the way they want it done with no one looking over their shoulder. One of the great things about this industry is there's plenty of room for both to be successful.

The two feature profiles in this month's issue of *Cleaner* are a testament to that. North American Pipeline Services is a great example of a company with a wealth of resources branching out to gain greater market share. Owner Tom Mullen had been in the excavation and pipe installation business for many years before purchasing the company. After the acquisition, one of his first initiatives was going after larger municipal jobs. North American had taken on very little of this type of work under the previous owner, but Mullen saw it as a huge opportunity for growth. The effects of Superstorm Sandy in their local area of New Jersey made municipal work an even greater opportunity.

is also looking at other upgrades. Three jet-vac combination trucks along with air-testing gear, mandrels and vacuum-testing equipment add to the resources available.

It's all part of Mullen's long-term vision: to combine North American Pipeline with his excavation business and create a full-service underground utility contractor that can compete directly with larger firms in New Jersey and adjacent areas of New York and Pennsylvania.

Tight Seal Plumbing in Chattanooga, Tenn., takes the same approach to doing quality work, but it's a small company and owner Daniel Baker only has one full-time employee. He may add to the staff in the future, but right now he's building the company name and customer base so he has a solid footing for whatever the future brings.

Baker prefers to be out on every job himself, and he's seen the value in focusing his business on drain cleaning. By carefully acquiring the right equipment,

Both of these entrepreneurs are successful by their own standards, even though they occupy very different places in their markets. They are on different tracks, but both are meeting the needs of their customers and doing well enough to meet the needs of their families.

So, nearly from scratch, Mullen began building capacity to take on those projects through training, networking and marketing.

Instead of waiting for existing customers to call, they're trying to grow relationships with a bigger, broader customer base. Mullen is making plans to expand into pipeline rehabilitation using slip lining and other forms of trenchless pipe repair. The company has several CUES cameras and support vans, and

he's been able to expand his capabilities and carve out a profitable niche.

He was able to learn from other experienced inspection technicians before he purchased his own equipment, and he spent a lot of time learning the full extent of the equipment's capabilities once he purchased his own.

Baker also pays close attention to detail and has been able to build his business through referrals from satisfied customers. "I'm going to give the best I possibly can," he says. "The customer has entrusted me to do that. We need to strive in the industry for that excellence."

Both of these entrepreneurs are successful by their own standards, even though they occupy very different places in their markets. They are on different tracks, but both are meeting the needs of their customers and doing well enough to meet the needs of their families. That's a success by anyone's standards and a great example of why this industry is great: If you do good work and treat people fairly, you'll find success.

Enjoy this month's issue. 



OBLITIROOT

- Kills roots in sewer lines
- Has 3x the dichlobenil
- Leaves a thicker coating
- Prevent regrowth longer

www.OBLITIROOT.com
(855) 782-4534

GET MORE

News, information and features
with our exclusive online content.
www.cleaner.com/online_exclusives

They say You Can't Have It All! We say: "Yes You Can!"

You can count on Duracable Manufacturing to provide you with all the tools you need for plumbing and drain cleaning. Durable, heavy duty, reliable tools that will help you make your business a success.

Cable: Available in wide range of sizes and types. Inner core, hollow core, oil tempered, standard, all made of the finest steel, right here in the USA.

Drain Cleaning Machines: Designed and manufactured right here in our own factory in the USA. From small light sink machines to big brutes that can handle mainlines, and everything in between.

Machine Accessories: Power Cable Feed and Return kits, Reel Carts, Loading Ramps and more.

Blades: High quality steel used in every blade, designed and manufactured in our factory. Blades that fit any need, any machine. As well as Chucks, spindles, end fittings and blade holders.

ProClean® Drain Care: For treating drains after they've been cleaned and keeping them running clean. Private labeling available too.

Looking for more? Just give us a call.

A one-stop source for all your plumbing and drain cleaning needs—Duracable Manufacturing. Just pick up the phone and call 877-244-0556 Or visit us on the web at www.duracable.com

MADE IN THE
USA

Duracable
Manufacturing Company

877-244-0556 • www.duracable.com

Rely on Reelcraft



Photo courtesy of Vactor, a subsidiary of Federal Signal Corporation

Special paint colors and finishes ▶



Did you know... Reelcraft can build to your specs?



Reelcraft's Capabilities

- ✓ Built to your exact needs
- ✓ Very few size and weight constraints
- ✓ Special finishes/paint options
- ✓ Various drive types
- ✓ Wide range of pressures
- ✓ No minimum quantities

To learn more visit us at www.reelcraft.com/custom



Multiple spools ▲



◀ Turn-key systems



REELCRAFT®

www.reelcraft.com | 800-444-3134

Read more stories that impact your business at Cleaner.com

BY LUKE LAGGIS

We're posting valuable new content every day at Cleaner.com. In addition to everything you see on these pages, the site features a wealth of product and industry information, as well as original features you won't find in print. The following are just a few of the items you're missing if you're not visiting the website.

Choosing the Best Inspection Camera for Your Business

Inspection cameras are one of the most valuable tools for any drain cleaner. Whether you're checking a line to diagnose a problem before beginning a job or you need to locate a blockage to determine how to clear the line, the inspection camera is a must-have.

"The typical use for your everyday plumber for an inspection camera is to locate a blockage or a break in the line," says Justin King, vice president at Amazing Machinery Inc. "They want to see the condition of the pipe, understanding if any service or repairs are needed to that line."

11 Management Tips to Increase Employee Performance

Many business owners and managers wonder how to keep employees motivated. They say, "I want employees excited to come to work; we have too many clock-punchers. How can I get them to do more and be more for our customers?" or "I feel like as soon as I put out one fire, another one erupts among employees. I'm tired of being a referee. They don't work as a team."

Reader Pipelines: Customers Make Business Worthwhile

Drain cleaning contractors all have a story to tell, whether it's about the ring you recovered from a drainline or the pro bono work you do in your community. This exclusive online Cleaner feature gives you a chance to tell your story, in your words, in a Q-and-A format that reaches beyond the confines of your business. Frank King, the owner of Action King Services of Lowell, Mass., is one of those with a story to tell.

How To Market Emergency Drain Cleaning Services

It doesn't matter what type of business you're in; people will call you with problems, looking for solutions. Your top marketing person should answer the phone when these calls come in. The ideal salesperson will make your services accessible to the caller and be expeditious in offering help. Make sure you've listened to, recorded and trained your phone person. Your business probably doesn't generate much money on emergency work, but the goal is to convert the emergency client into a long-term, loyal customer.

3 CIPP Products Every Pipe Rehabilitation Contractor Needs

When you are called on to rehabilitate storm drains, sanitary sewers and pipelines, your customers need to feel confident that you have the tools to get the job done quickly and efficiently. Cured-in-place lining has come a long way in the years since its development and the equipment and methodologies have also evolved.

Check out all these stories at www.cleaner.com/ec/2013/August

Ready, Set, Jet

US Jetting 4018 - 300
4000 PSI @ 18 GPM

US Jetting 6018 - 300
6000 PSI @ 18 GPM



Our US Jetting 4018 - 4000 PSI @ 18 GPM Unit Offers The Best Cleaning Power In The Industry. Our NEW US Jetting 6018 - 6000 PSI @ 18 GPM Unit Is Just A Whole Lot Better

www.usjetting.com
1-800-538-8464
sales@usjetting.com
1-800-jetting



The US Jetting 4018 - 300 Gallon trailer unit for years has provided contractors with the best pipe cleaning capability & return on investment. The New US Jetting 6018 - 300 Gallon unit is a step up in pressure, allowing more difficult jobs to be completed in a timely manner. The New 6018 units can run at 4000 PSI for average jobs or run at 6000 PSI with the change of a nozzle for difficult jobs providing maximum 18 GPM flow. At 6000 PSI, roots & grease don't stand a chance.

850 McFarland Parkway, Alpharetta, GA 30004

YOUR TOUGHEST JOBS START & END WITH ENZ!

★ A TOOL FOR EVERY PIPE CLEANING APPLICATION ★



- ★ ROTATING NOZZLES WITH SPEED CONTROL
- ★ CHAIN FLAIL HEADS FOR ROOT CUTTING
- ★ IMPACT DRILLING CUTTER HEADS FOR CUTTING CONCRETE
- ★ VIBRATING ROTOJETS

Enz golden jet is the leader in sewer and pipeline cleaning equipment, offering a versatile, durable and economical line of virtually maintenance-free products, which outperform the competition time and again.

3 6 9 - 8 7 2 1
CALL 1-877-ENZUSA1

to learn how easily Enz Golden Jet Nozzles can fit into your existing operation.

enz®  **usa inc.**

1585 Beverly Ct., Unit 115 • Aurora, IL 60502

www.enz.com



STRONG, FAST AND ENGINEERED TO LAST!

INVENTORY REDUCTION SALE



- Standard accessory package
- 1,300 gallon water supply
- 400 gpm pump off system
- 12 yd³ debris body
- 600' articulating hose reel
- Gravity drains system
- 3-stage blower, hydrostatic driven
- 10' hydraulic telescoping boom with pendant control
- 80 @ 2000 water pump with 4-cylinder diesel auxiliary engine



YEAR	CHASSIS	HOURS	MILES	PRICE
2008	Peterbilt PB365, Cat® C9 335 HP	2,679	22,135	\$215,000
2008	International, 7400 MaxxForce 300 HP	5,452	20,204	\$210,000
2008	International, 7400 MaxxForce 300 HP	6,106	12,533	\$205,000

Ring Power



Matt Taylor, 850-514-1958
Matthew.L.Taylor@ringpower.com

ALL TRUCKS LOCATED IN FLORIDA



predator or prey



WOLVERINE
CUTTING SYSTEM

Are your budgets getting eaten up due to long set-up times? Have you been a victim of low productivity due to poor cutter performance? Now you can attack the challenge of lateral reinstatement cutting with the Wolverine Cutting System.

Hunt down and reinstate your laterals rapidly and accurately with this self-propelled cutter. The Wolverine provides a feature-rich, powerful alternative to your current cutting equipment.

**Are you predator or prey when it comes to pipeline rehabilitation?
Call Aries today and start tracking your success.**



www.ariesindustries.com | (800) 234-7205

ARIES
INDUSTRIES, INC.

See what you're missing.

BORN AGAIN

NORTH AMERICAN PIPELINE SERVICES DELVES DEEPER INTO PUBLIC PROJECTS TO EXPAND ITS BUSINESS AND RESTORE THE SHORE **BY ERIK GUNN**

When Fred Choppy decided to sell his sewer cleaning and inspection company, North American Pipeline, last year, he didn't have to look far for a buyer.

The 39-year-old business, based in Freehold, N.J., was operating primarily as a subcontractor in the commercial markets with some limited municipal work. Last year, Tom Mullen IV, an excavating contractor and old friend of the Choppy family, bought the firm.

Now, working with Fred's son, Mullen is positioning the operation to expand beyond its original portfolio. He's going after larger public-sector contracts and seeking to build a reputation all over the Garden State.

NAP is making its bid for growth at an especially propitious time. Last fall's devastating Superstorm Sandy hit just as Mullen was getting ready to close on his purchase of the company. In the weeks and months since the storm paralyzed so much of the Northeast and wrought billions of dollars in damage, NAP has been busier than ever, taking on bigger and bigger projects.

It's all part of Mullen's long-term vision: to combine North American Pipeline with his excavation business and create a full-service underground utility contractor that can compete directly with larger firms in New Jersey and adjacent areas of New York and Pennsylvania, instead of just being a subcontractor. He's even added "Services" to the company's name.

"A major amount of the tri-state area infrastructure is past its useful life expectancy and will have to be serviced, repaired or replaced," Mullen says.

FAMILY TRADITION

Contracting is in Mullen's blood. He's the fourth generation in his family to be in the excavation and utility business in some manner. Back in high school he worked summers for his father, Thomas Mullen III, who owned an excavation business, and then full time for the company after graduating.

The younger Mullen moved on to the real estate development business, working for Renaissance Properties in the 1990s. After housing sales sagged in 2000, Renaissance owner Bob McDaid decided to branch out. Mullen and

profile

NORTH AMERICAN PIPELINE SERVICES, LLC, FREEHOLD, NJ



OWNER:	Tom Mullen IV
FOUNDED:	1974 as a small plumbing firm; acquired 1984 by Fred Choppy, who built a pipeline service business; acquired 2012 by Tom Mullen IV
SPECIALTIES:	Cleaning (storm and sanitary sewer), inspection, testing (sewer, manholes, potable water systems), hydroexcavation, replacement and repair (sanitary sewer, storm drain, potable water systems)
SERVICE AREA/TERRITORY:	New Jersey
EMPLOYEES:	10
ANNUAL REVENUE:	\$1 million (includes Mullen's affiliated excavation company)
WEBSITE:	www.napllc.com

McDaid formed an excavating company to do utility pipe installations and repairs as well as site work for construction projects. With his own background so close to the industry, Mullen asked McDaid to put him in charge of the excavation business, and McDaid agreed.

The Choppy and Mullen families were friends. Mullen's father's excavating company had subcontracted sewer inspection and cleaning work to Choppy's business, and now the younger Mullen did, too.

"NAP has always been around for as long as I can remember," Mullen says. "All the time, I always said to Fred, 'When you're ready to sell, I would love the opportunity,'" Mullen says.

That opportunity finally came in 2012 when Fred Choppy decided to retire. With McDaid's assistance and the vision of combining the two businesses, Mullen jumped at the chance, closing the deal a week before Christmas 2012. Choppy's son, Brad Choppy, came along with the company, and has the day-to-day responsibility of managing projects as vice president at NAP.

"A major amount of the tri-state area infrastructure is past its useful life expectancy and will have to be serviced, repaired or replaced."

Tom Mullen



Richard Szabo, of North American Pipeline, works the vacuum truck during post-Sandy cleanup at Ocean Beach III in Chadwick Beach, N.J., in early April. The company has been conducting clean-up work in the area since Hurricane Sandy hit in 2012. (Photos contributed by North American Pipeline)

Brad Choppy, supervisor of field operations with North American Pipeline, operates one of the company's jet-vac trucks at a job site along the Garden State Parkway. (Photo by Jerry Wolkowitz)



PUBLIC WORKS EXPANSION

Public works is a big part of Mullen's plan for the business. Before he bought it, "Fred never really went after any public work unless it was through another contractor," Mullen says.

He understands why. "There's a huge amount of paperwork," Mullen notes. "It's almost as demanding, if not more demanding, as the actual physical work, which is the enjoyable part."

Companies taking on public projects must get bonding. Office employees need to meet strict documentation rules for bonding and for bidding work, which requires training. And workers in the field need certification that they've been properly trained in safety standards required by public works projects.

"If a private contractor is driving along the Parkway and they see all of our trucks out there, they're going to have that kind of reassurance that you're a company to reckon with and that's capable of performing jobs."

Tom Mullen

But Mullen sees some big benefits in the arena. "There's definitely a good-sized market," he says of public works, and the need to repair and upgrade infrastructure is only growing.

And while there are hoops to jump through, he sees public work as potentially more secure. "You're guaranteed to get paid when you do public work," Mullen says. "You're not chasing your money."

Win or lose, bidding projects is getting the company's name out, and lately he's begun to win.

And the high profile of public work, he believes, may help market in the private sector, too — one reason that NAP has made sure its trucks are decorated in bold colors with engaging graphics. "If a private contractor is driving along the Parkway and they see all of our trucks out there, they're going to have that kind of reassurance that you're a company to reckon with and that's capable of performing jobs," Mullen says.

BUILDING CAPACITY

So, nearly from scratch, Mullen began building capacity to take on those projects through training, networking and marketing.

Safety training for National Association of Sewer Service Companies (NASSCO) certification is under way now. Employees have also been trained in the Hazardous Waste Operations and Emergency Response Standard (HAZWOPER).

"When you get into the public sector it's

(continued)

TOUGH JOBS TOUGHHER TOOLS

ONE CALL

1-800-231-3628

For all your water jetting needs.
ALL of them.

GD

GARDNER DENVER
WATER JETTING SYSTEMS, INC.

(1) 281-448-5800 **Phone**
(1) 281-448-7500 **Fax**
(1) 800-231-3628 **Toll-free U.S. & Canada**

www.waterjetting.com





Brad Choppy pulls tools from a storage compartment on a jet-vac truck while working along the Garden State Parkway.

imperative that your personnel are trained for occupational safety," Mullen says.

And while there's plenty of work, it doesn't just come by itself. "Instead of just sitting there, waiting for the phone to ring, based on past relationships, we're trying to grow our relationships to a bigger, broader customer base," Mullen says.

NAP has joined the Utility Transportation Contractors Association (UTCA) and other regional groups to help get the word out about its capabilities, and also get the word in on work opportunities, such as information providers who track when communities are getting ready to bid work.

Another tool was putting the company on the Web in a big way. Mullen says that before the change in direction, NAP didn't have or need a significant Web presence.

CLEANING UP

All that work has begun to pay off. Recently the New Jersey Turnpike Authority embarked on a project to reline storm drain culverts on the Garden State Parkway — the main highway that hugs the New Jersey shoreline from Cape May to the New York state line in the far northeast corner of the state. The general contractors tapped North American to do the pre-cleaning prior to culvert installation.

"That will be our first, real official highway job," Mullen says.

In the meantime though, Superstorm Sandy has made a lot of work for NAP, some of it months after the late October storm.

In mid-April, the company was hired by the community of Chadwick Beach, located on a spit of land in the Atlantic Ocean, to clean up storm drains that had been silted and covered over by the storm. For that they were again

EXPANDING THE FAMILY

Fred Choppy owned North American Pipeline before Tom Mullen IV bought it. And Choppy also had a son, Brad, working for the company. In fact, Brad Choppy still works for the company, and thus for Mullen.

"We've known Tom for a long time," Brad Choppy says. Mullen, he adds, was far and away better positioned to buy the company than he would have been.

"Tom's got a significant amount of contacts and clients. His pockets are a little bit deeper than mine."

And he liked Mullen's plan to marry his excavation business with the pipe company. "I thought it would be a great idea," Choppy says, and he and Mullen agreed that Choppy would stay on to run the pipeline business day to day.

"He does everything from bidding to procurement to actually running the trucks," Mullen says. "That's the best guy to have on your side."

hired by another contractor who figured that North American might know the site better because it had cleaned storm drains there in the past.

"It was so silted over they really didn't have a good idea where the lines run," Mullen explains.

That wasn't the first Sandy job. In the weeks after the storm, North American was called in by the borough of Deal, just north of Asbury Park, to clean up a sewage pumping station that had been overwhelmed by ocean waves whipped up by Sandy.

(continued)

B-10
Rear Reel



NEW!

F-10
Front Reel



AQUATECH[®]

Jet/Vacs

A Product of Hi-Vac[®] Corporation

The Difference Is **REEL!**[™]

Regardless of whether you prefer a rear reel design (Aquatech B-Series) or our new front reel design (Aquatech F-Series), Aquatech offers you the best of both worlds.

Choose the sewer cleaning system that's right for you.

**Modular Design • Easy Operation • Simple Maintenance
Maximum Efficiency • Ergonomic Design • Global Sales & Support**

1.800.752.2400 740.374.2306
www.aquatechinc.com

Environmental Products for a Cleaner World

AQUATECH
A Product of Hi-Vac[®] Corporation

O'BRIEN
A Product of Hi-Vac[®] Corporation

Hi-Vac
A Product of Hi-Vac[®] Corporation

ultraVac
A Product of Hi-Vac[®] Corporation

X-VAC
HYDRO EXCAVATOR
A Product of Hi-Vac[®] Corporation

Scan for video on
our NEW F-10





Brad Choppy, left, supervisor of field operations for North American Pipeline, and company owner Thomas E. Mullen stand by their state-of-the-art jet-vac truck in the Monroe Township, N.J., yard. In the background Richard Szabo, (left) a field technician and operator, and George Schneider, a maintenance and logistics foreman, attach a tube to the vacuum hose.

The building is 30 by 30 feet and three stories tall. Waves had roared over the building with such force that they destroyed the roof and flooded out a backup generator on site.

Choppy, who headed up the operation, says they could see the sun bright as day through where the roof had once been. "Everything was all shut down. It had knocked down the walls of the bathroom."

An office on the top floor – the building's entry floor – was all but demolished. "The computer, the desk, everything was destroyed," Choppy says.

Cleaning required vacuuming out the pit at the bottom level of the structure, while other debris was too big even for the vacuum truck and had to be hauled out.

FIFTEEN TONS

At another sewage station that NAP was called to clean, in Lake Como, crews found a door ripped off, an exhaust fan destroyed by a log that was stuck in it, even a piece of a handicapped-parking sign from the community's boardwalk that had been ripped up by waves and washed over to the facility.

"We had to clean that entire facility," says Choppy. "There was 15 tons of material in there, from sewage to whatever else."

While North American was experienced in sewer and storm cleaning, this was something else, he says, both because of the amount of sand and the amount of debris – everything from cans and bottles to logs and more. "We found a car one time," Choppy says.

Choppy, right, confers with representatives from consulting engineers J. Fletcher Creamer & Son about the locations of the basins they are to clean along the Garden State Parkway, in Clifton, N.J.



EYEING NEW AREAS

Looking ahead, Mullen is making plans to expand into pipeline rehabilitation using slip lining and other forms of trenchless pipe repair. The company has two CUES sewer cameras and their support vans (one a Ford, one a Chevy). It also has three CUES mini-cameras and is looking at upgrades. NAP recently acquired a camera that can go into pipe as small as 1.5 inches, and also has a built-in locator.

"Instead of just sitting there, waiting for the phone to ring, based on past relationships, we're trying to grow our relationships to a bigger, broader customer base."

Tom Mullen

Three Jet-Vac combination trucks along with air-testing gear, mandrels and vacuum testing equipment add to the resources available.

Mullen is also watching the many new technologies proliferating in the market.

Eventually he sees the excavation company and the pipeline services business coming under the same umbrella, "to become a one-stop shop offering full pipeline service," says Mullen. "Hopefully being under one roof will give us a competitive edge."

North American Pipeline may be four decades old, but that's still young. Mullen points out, however, that it has deep experience even as it's being, in some respects, reborn.

And it's got another key asset, he adds: "Now what's here is a massive amount of drive." ☐

more info

CUES
800/327-7791
www.cuesinc.com
(See ad page 55)

Jet-Vac Sewer Equipment Service Center
800/527-4469
www.jet-vac.com

Allan J. Coleman – Since 1905

Call us today! 773-728-2400

5725 North Ravenswood Avenue • Chicago, IL 60660 • info@allancoleman.com

StoneAge® Warthog® Nozzles



WD-1 1/4"
(8-36" lines)



WG-1"
(8-36" lines)



WH-1/2
& 3/4"
(6-18" lines)



WS-1/2"
(4-8" lines)



WT-3/8"
(3-6" lines)



WV-1/4"
(2-4" lines)

**CALL FOR
GENERAL
SPECIALS**

Special pricing
on all
**General jettors,
cameras and
machines**



Repair Center for: RIDGID SeeSnake, Gen-Eye, Radiodetection, Electric Eel, Vision Technology, Insight Vision & Spartan Cameras **Fast Turnaround Time**

UPGRADE your camera system to the GVISION. A Better System

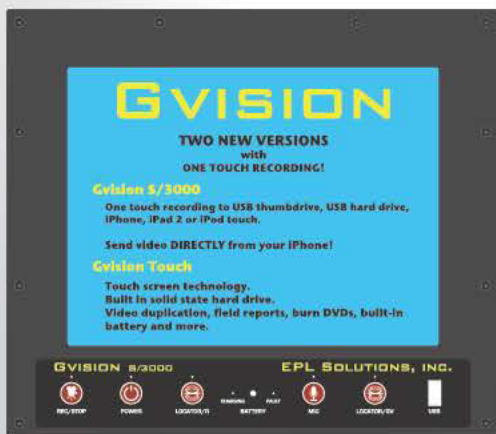

GVISION
Visit www.eplsolutions.net for more details.



Ask what the
GPLAYER
can do for you?



JetSonde Carriers - P-Trap Cable Sonde Carriers

Turn ANY push camera into a Jetter Camera
with the JetCam Adapter.

Jetter Hose

JetSonde Nozzle

JetCam Adapter



OLDEST NAME IN THE BUSINESS
— Over 100 YEARS OLD — PHCC MEMBER

GIANT

When Quality Matters

KAMAT

Pumps built for long life.

With Giant's KAMAT line, earn more money.

- Long Life
- Less Downtime
- Better Safety Controls
- Automatic Feed



- ▲ Enclosed or open trailer jets.
- ◀ Skid-mounted units.
- ▶ Full line of accessories.



PERFORMANCE UNDER PRESSURE

Giant Industries, Inc., 900 N. Westwood Ave., Toledo, OH 43607
419-531-6836 • 419-531-6836 [FAX] www.giantpumps.com

View and capture maximum details at every angle.

NEW!

Unparalleled imaging
Pans 360°, tilts 210°.

Pan n' Tilt
Push Camera
(Includes Reel and
Remote Control)



Optional
Steerable
Gooseneck



Record to
Cell Phone or iPad

Ultra Micro™
5/8", 3/4", 1" Available



Fast Peek™



Inspector PC®-xl



Locator



Jet Cam



Elite Jr.®

Trust the industry leader for consistent innovation.

For over 32 years now, Ratech Electronics has been at the forefront in the development, manufacturing and servicing of CCTV video pipeline inspection camera systems and equipment. Serving the municipal, industrial, and residential markets, our innovative products are created and manufactured with the quality and durability industry professionals demand.



Staying ahead of your customer's needs.



For more information on these or other products call
toll free: 1-800-461-9200 or 905-660-7072 or visit ratech-electronics.com

Ratech
ELECTRONICS

Upload your inspection videos to **YouTube** Ask us HOW?

Follow us on Twitter @RatechCam

Video Pipeline Inspection Systems

Don't show up to a job
unprepared.



Stock your equipment with the right parts to get the job done.

Think of FS Solutions® as your personal **Parts Supplier** for all makes and models of
Industrial Vacuum Loaders, Vacuum Excavators and Waterblasters.

7 locations - same day shipping - huge inventory - competitive prices - expert technical and application advice.



fssolutionsgroup.com • (800) 822-8785

Brute Force

CART-MOUNTED WATER JETTER OPENS UP A NEW MARKET FOR ILLINOIS DRAIN CLEANER WHILE IMPROVING PRODUCTIVITY AND PROFITS

BY KEN WYSOCKY

When Chad Andersen decided last summer to take a step up to more powerful drain-cleaning equipment, he sought a machine that could seal the deal in terms of customer satisfaction and improved efficiency. He found what he was looking for in a cart-mounted Brute Series water jetter from JETTERS NORTHWEST.

Along with a RIDGID SeeSnake pipeline-inspection camera, the portable Brute gives Andersen, the owner of Andersen Plumbing and Drain Cleaning in Aurora, Ill., the confidence that he can unclog any drainline, quickly and profitably. And in doing so, he helps customers avoid expensive sewer lateral repairs, which in turn generates word-of-mouth referrals, as well as repeat business for maintenance and line cleanings.

“I didn’t want to be that guy who pokes a hole in it [an obstruction] and then comes back six months later to fix the same problem, or tells someone they need a new line when they really don’t,” Andersen says. “The camera and the Brute help us do our work with honesty and integrity.”

To underscore his confidence in the Brute, he relates a story about a customer who hired another contractor that couldn’t clear out a lateral with a sectional cable machine. The customer was leery about hiring another

contractor, so Andersen told her he wouldn’t charge her anything if he couldn’t determine the cause and resolve the problem.

“She thought I was nuts,” he recalls. “I strapped my camera head to the Brute’s hose and found tree roots about 85 feet out. The other contractor went out 160 feet, even into the mainline sewer, but still didn’t clear out the roots. But the Brute did. We were done in two hours. The other guy had been there for the better part of a day.”

money machines

OWNER:	Andersen Plumbing and Drain Cleaning, Aurora, Ill.
MACHINE:	Brute Series cart-mounted water jetter, made by JETTERS NORTHWEST
FUNCTION:	Primarily residential drain cleaning
FEATURES:	12-gallon water tank; 25 hp Subaru propane-fueled engine; UDOR U.S.A. pump (8-1/2 gpm at 3,600 psi); 200-foot remote reel
COST:	About \$10,000, with accessories

The Brute water jetter by JETTERS NORTHWEST has given Andersen Plumbing and Drain Cleaning the ability to unclog any drainline, quickly and efficiently. (Photo courtesy of Chad Andersen)



The Brute features a 12-gallon water tank (which Andersen supplements with a 65-gallon cart-mounted tank when needed); a 25 hp Subaru engine that runs on propane fuel; a UDOR U.S.A. pump that produces 8-1/2 gpm at 3,600 psi; a 200-foot remote reel with a shut-off valve; a Warthog rotating jetter head from StoneAge Inc.; and 300 feet of 3/8-inch-diameter hose.

Andersen also owns a large, trailer-mounted jetter made by Harben Inc. (300-gallon water tank/18 gpm at 4,000 psi), used for larger commercial and municipal jobs; and three smaller drain-cleaning machines made by Spartan Tool LLC. By gradually accumulating an array of drain-cleaning tools, he's been able to shift the primary focus of his business from plumbing repairs and installations to more lucrative drain-cleaning jobs.

"We are able to net more profit on these jobs because we charge extra to run this equipment," he points out. "In the first half of this year, I've already made more gross income than what I earned during my first year in business in 2011.

"Any machine that you can bring in and make what you paid for it in five months is worth having."

Chad Andersen

"The average invoice for a drain-cleaning job is much higher than one for, say, a toilet repair, which is why I decided to focus more on drain cleaning," he adds. "Our growth has been unbelievable, and I attribute most of it to adding drain-cleaning services."

Andersen says the Brute – which he uses primarily for cleaning out residential sewer laterals, as well as commercial work – basically paid for itself in about five months. "Any machine that you can bring in and make what you paid for it in five months is worth having," he notes.

The Brute's portability and its propane-powered engine allows Andersen to use it indoors on commercial jobs. That gives him an edge over companies that own only larger, trailer-mounted jetters that require long hose runs that can disrupt business operations.

"That means the company has to shut down traffic in an area, or maybe leave doors open that should be secured," Andersen points out. "But with the Brute, I can wheel it right in, which you can't do with gasoline-powered units. I just bring along a water hose, or use my cart-mounted water tank, and work without snaking a hose all over the place. Customers love it ... it's all about making things easy for them.

"Another thing that makes the Brute shine is that its pressure flow is pretty close to that of a small trailer jetter," he added. Moreover, for jobs that require working several stories high, the portable Brute doesn't lose water pressure the way a trailer jetter does on jobs that require a long vertical hose run.

Along with accessories, Andersen paid about \$10,000 for the Brute. But he says it's a small price to pay for a machine that seals the deal in terms of customer satisfaction and increased productivity and profitability. **c**

SHOW US THE MONEY (MACHINE)

Money Machines, a feature in *Cleaner*, reports on innovative work vehicles that help contractors operate more efficiently, satisfy customers and earn more profit. We'd like to know about your Money Machine — be it a service van, camera truck, jetting rig, vacuum unit or any vehicle that really helps drive your business. To nominate your vehicle for a feature in this column, send an email to editor@cleaner.com. Tell us briefly but specifically what features make it a great producer. And send a picture — because appearance counts. We look forward to seeing your Money Machine.



Self-propelled **IST PC200** for pipe 8" (relined) and up delivers 1.9 hp, articulates on 4 axes, and views with a remote-tilt vibration-cancelling camera.

Cut ahead.

Deliver more and earn more with PRT's full range of top-performing cutters.

Robotic cutters from PRT redefine what's possible when cutting in drains, prepping for relining, and reinstating laterals. Exceed expectations—choose PRT for the agility and power to cut ahead.



Positioned with remote air bladders, **IMS Micro** travels 100' into laterals 3-6", maneuvers past elbows, articulates on 2 axes, and views with an illuminated camera.

Rental program.

Any cutter can be rented for trial purposes, or for a specific job.

Pipeline Renewal
TECHNOLOGIES™

www.pipelinert.com
(973) 252-6700

© 2013 Pipeline Renewal Technologies. All rights reserved. PRT name and logo are trademarks of Pipeline Renewal Technologies.

Save time: clean 2 tubes at once

A Saflex™ 2000 is twice as productive as manual water jetting. It cleans two tubes at once, with flexible tubes to handle bends. Key features include:

- pressures up to 40,000 psi
- eliminates lance contact by the operator
- manual indexing or optional X-Y positioner with wireless controls
- the ability to adjust to tube length and diameter

Make your operators more productive with a Saflex 2000... or a Saflex 3000 or ATL-5000 for bigger jobs. For a video demo or white paper, visit www.nlbcorp.com.

NLB Corp. The Leader in Water Jet Productivity

29830 Beck Road, Wixom, MI 48393
MI: (248) 624-5555, IN: (219) 662-6800, NJ: (856) 423-2211
LA: (225) 622-1666, TX: (281) 471-7761, CA: (562) 490-3277
www.nlbcorp.com • e-mail: nlbmktg@nlbusa.com



HURRY ORDER TODAY! SALE ENDS 8/30/13

SAVE NOW ON 3/4" CABLES*

DRAINABLES
direct



Call 800.421.4580 | Visit draincables.com



*Prices effective through 08/30/13. Sale pricing may not be combined with quantity discounts or special pricing. Some exclusions apply.

Hammelmann High Pressure Technology

Our fleet of rental pumps range from 5,000 PSI to 50,000 PSI with flows to 70 GPM.



Hammelmann is dedicated to supplying contractors with the tools they need for all kinds of different applications.

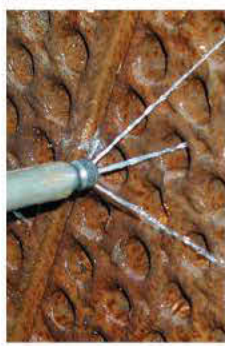

The new pump generation
HDP MC high pressure pump. The most compact 1500 HP unit available. 100 GPM @ 20,000 PSI.



3D Tank Cleaners available for rent or purchase with pressures up to 26,000 PSI and flows exceeding 150 GPM.

Manual, semiautomatic and Robotic HP/UHP blasting tools and systems. Everything you need for cleaning, surface prep., concrete cutting and demolition.

New Houston facility

Our commitment to the industrial water blasting sector will be underlined by transferring to a much larger custom built facility better equipped to service the increasing demands of an expanding market.



It comprises a 10,000 sq/ft building with offices, showroom, conference room, workshop area, automated inventory control and state of the art test facility plus a fully secured 1 acre yard for the rental fleet located at:

New Houston address
Hammelmann Corp. Houston
Toll-free: 1-866-317-8677
bill.obriant@hammelmann.com
402 S.H. 146 south
La Porte, Texas - 77571

Contact us to find out how you can take advantage of high and ultra high pressure water in your business. We look forward to hearing from you.



Hammelmann Corporation
Toll-free: 1-800-783-4935
mail@hammelmann.com
600 Progress Road
Dayton, OH - 45449

hammelmann.com



SPX



NEW!
On-board
battery option

GATORCAM[®]4 SYSTEM



CLASS LEADING FLEXIBILITY. SUPERIOR PICTURE QUALITY. OUTSTANDING VALUE.

The GatorCam4 system delivers flexibility, advanced digital technology and outstanding picture quality.

- Weatherproof, rugged and cost effective portable inspection package, now with optional on-board battery.
- Inspection capabilities from 1 1/4" (32mm) to 9" (230mm) with a built-in flexible sonde.
- Compact Flash or USB flash drives for recording and data transfer.
- Digitally pan, zoom and rotate live pictures and record in MPEG4 and JPEG.
- Full titler with 20 pages of text and built-in reporting.

To find out more call us on **+1 (877) 247 3797**, or email rd.sales.us@spx.com

www.spx.com www.radiodetection.com

> Radiodetection[®]



PRIMELINE PRODUCTS, INC.

"Your Prime Source for Solutions, Products, and Training"



Primeliner[™] CIPP Sectional Lining Materials

Save up to 75% off Kit Pricing!

- FiberGlass with Felt Scrim
- Silicate Resins
- Epoxy Resins
- Carrier Packers

FREE Training
from Experienced
Personnel

24/7 Customer
Support

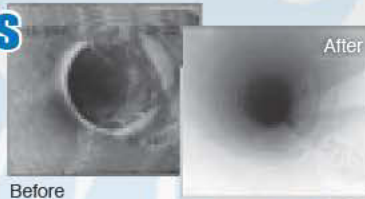

Before

After

Primeliner[™] QuikShot

Fastest Lateral Lining gun in the World!

- Installation of unlimited liner lengths
- Ambient or Hot water Cure with Quik Heater
- Financing Available



Quik Shot Gun



Quik Heater

Accepting



Call Us Today!!! (407) 772-8131 or (877) 409-7888

Visit our Website: www.primelineproducts.com

[Facebook.com/PrimeLineLining](https://www.facebook.com/PrimeLineLining)

See for yourself!!!

You Tube See our Youtube channel www.youtube.com keyword: **PrimeLineLining**

Scan the QR Code at right with your smart phone to view a video



September 9-11, 2013
George R. Brown Convention Center
Houston, Texas

FREE ADMISSION!*

Pre-Registration Recommended

Celebrating
30 Years
1983-2013

WJTA-IMCA Conference and Expo

*High Pressure Waterjet/Waterblast Tools and Systems
Industrial and Municipal Cleaning and Maintenance
Vacuum Trucks/Hydroexcavators/Sewer Jetters*

■ Network with Industry Professionals

Your chance to connect face-to-face with industry professionals from around the world: build new relationships and generate new business opportunities.

■ Educational Seminars - Boot Camp for Contractors and End Users

Stay competitive in today's marketplace - learn cutting edge applications, techniques and safe practices.

■ New High-Tech Equipment, Trucks, Parts, and Accessories

■ Waterjet Technology Short Course

High pressure waterjet technology basics and more. This course covers applications (industrial cleaning, field/shop cutting, robotics, surface preparation), safety and equipment.

■ Live Demonstrations

- Robotic Hydroblasting
- Vacuum Truck/Hydroexcavation
- Paint/Coating Removal/Surface Prep
- Waterjet Field Cutting
- Heat Exchanger Cleaning
- And more...

■ Research Papers - Emerging Technologies, New Applications

Opportunities to Win Cash and Prizes

REGISTER NOW

online at www.wjta.org,
email wjta-imca@wjta.org, or call (314)241-1445

WaterJet Technology Association (WJTA) and Industrial & Municipal Cleaning Association (IMCA)
906 Olive Street, Suite 1200, Saint Louis, MO 63101-1448
Email: wjta-imca@wjta.org, Telephone: (314) 241-1445, Fax: (314) 241-1449

* Free admission applies to exhibit hall, live demonstrations, and boot camp. Registration fees apply for short course and research papers.



Cold-Weather Equipped

FREEDOM WATER BLASTER TRUCK
DRAWS ATTENTION WITH EXPO DEBUT

BY ED WODALSKI

Without a closer look, visitors at this year's Pumper & Cleaner Environmental Expo International might have mistaken Freedom's WBT-3015B enclosed water blaster for a new type of water jetter, but that's hardly the case, says Titus Larson, superintendent designer/builder for Freedom Enterprises.

"This truck can go from 0 to 40,000 psi with a quick change of some plungers in a couple of minutes," he says.

Featuring an insulated (R-19 walls and roof) and heated 14-foot box with workbench and tool boxes mounted on a 2011 Peterbilt 337 Class B chassis, the water blaster is designed for extreme use in the coldest temperatures.

"We've got it running at about 12,000 feet and sometimes higher in extremely, extremely cold weather – down to 60 and 80 degrees below zero," Larson says.

"I talked to people throughout the course of the day [at the Expo]. Most of them liked the fact that it was hydrostatic; everything was in one unit and there was space for all of your tools and equipment."

Titus Larson

Featuring a convertible 150 hp triplex water pump, the waterblasting unit delivers 12 gpm at 15,000 psi or 23 gpm at 8,000 psi. Convertible up to 20,000, 30,000 and 40,000 psi, conversions can be made in the field. That translates into long-range pipe cleaning, he says. "This unit is capable of producing enough pressure and flow – we've gone as far as 1,800 to 2,000 feet in a single run."

The water blaster truck has a 925-gallon water tank with internal baffles, two 18-inch lid access doors, curbside 2-inch fill, copper coils inside the tank for heating water and a water level gauge. Other features include a hydrostatic pump drive system, high-pressure blow-off and burst disks for safety.

"I talked to people throughout the course of the day [at the Expo]," Larson says. "Most of them liked the fact that it was hydrostatic; everything was in one unit and there was space for all of your tools and equipment."

The cold weather package includes an air purge and antifreeze injection system, 45,000 Btu diesel-fired heater with programmable timer/controller and adjustable water temperature shutoff.

"That will do any type of heating while you're away or driving to the job,"



The WBT-3015B water blaster truck from Freedom Enterprises delivers 12 gpm at 15,000 psi or 23 gpm at 8,000 psi. It can also be converted in the field to operate at up to 40,000 psi.

he says. "While you're on the job you can use the truck engine to heat the water. It uses the extra engine heat and puts it through the tank. There's about 75 feet of coiling inside the tank. It takes about a couple of hours to heat 925 gallons."

The water feed and filtration system includes a hydraulic-powered, low-pressure pump (50 gpm at 25 psi), 220 gpm filter housing with quick-change filter bags, instant-off automatic protection, 1.5-inch inlet for hydrant water feed and 1.5-inch outlet for supplying water to multiple water blasters or trucks.

Primarily used in industrial applications – power plants and surface preparation, as well as cleaning oilrigs – the truck can be used on 2-inch residential up to 24-inch municipal sewer lines.

Storage includes 7,500-pound capacity wire rack shelving, flammable materials cabinet, above tank storage, workbench, vise and roller bearing mechanics tool box under the workbench.

"We've got a 5,000-watt inverter, air, water to wash hands; we've got any kind of tooling you might need," Larson says. "We try to stay warm in there, too. We've got the cab well heated."

The hydraulic-powered slide-out reel offers 1,800 feet of 1/2-inch hose capacity with variable drum speed and multi-position swivel for 320-degree rotation.

The truck is powered by a 300 hp (2,000 rpm) PACCAR PX8 engine with 12,350-pound front axle, 20,000-pound rear axle, air-ride suspension and 3,000-pound fold-up hydraulic lift gate.

"All of our controls are variable. You don't have to adjust it. We try to put ease of use into this piece of equipment while still being green," Larson says. "It's a one-of-a-kind. You won't see another one like it." 970/653-8588; www.freedomseweranddrain.com. c

PUMPER & CLEANER ENVIRONMENTAL EXPO
EDUCATION DAY: FEB. 24, 2014 EXHIBITS OPEN: FEB. 25-27, 2014
INDIANA CONVENTION CENTER - INDIANAPOLIS | PUMPERSHOW.COM

CENTURY TRAILER WATERBLASTING SYSTEMS

Power & Performance In a Radial Piston Pump Design



Pressures from 8,000 to 10,000 PSI

Experience the Harben difference

QUALITY

VALUE

SERVICE

RELIABILITY

Call today to schedule a demonstration. **1-800-327-5387**

 **HARBEN**®

High Pressure Water Technology

www.harben.com

Scan the code
below with your
smart phone
application



Introducing the vCam-5 Inspection Cameras

The vCam-5 Camera Systems have all the features that you liked in the previous models, with the addition of some great new features. The vCam-5 components are also backwards compatible with the previous vCamDigital and vCamModular systems.



Control Module

- WiFi and RJ45 computer interfaces
- One touch recording and still images
- Small profile, light weight and durable
- AC/DC powered with Li-ion rechargeable batteries
- Video streaming to Laptops and Smartphone's

Reel Coilers

- Mini and Standard sizes
- 512/640Hz locatable Sonde
- All stainless steel construction
- Heavy duty termination springs
- Narrow profile for easy deployment

Camera Heads

- Ultra bright LED's
- Modular repairable resin
- All stainless steel construction
- Full color auto upright cameras
- Auto iris adjust lighting automatically



Call us for your no obligation on-site demonstration!
Vivax-Metrotech Corporation

3251 Olcott Street, Santa Clara, CA 95054, USA
Toll Free: 800-448-3392 Email: sales@vxmt.com
Fax: +1-408-734-1415 www.vivax-metrotech.com



NozzTeq®

Taking Science to the Sewer!®

Equipment Engineered for Long Lasting Performance™

**Hydro-Excavating
Orbital Nozzle**
(2000 PSI - 36,250 PSI)

MONRO-JET®



Rental and Leasing Services Available!

Call For FREE DVD

www.nozzteq.com

Phone: 1.866.620.5915

Fax: 603.413.6744



"water as a tool"

WOMA®
CORPORATION

WOMA High Pressure Systems

help solve almost any Industrial cleaning, maintenance and decontamination problem.

- HIGH PRESSURE PUMPS TO 40,000 PSI
- 25-600 HP HIGH PRESSURE UNITS
- ACCESSORIES TO MEET ANY APPLICATION

Let us help you more effectively use "water as a tool."

When quality, performance and reliability matter...
PHONE: 800-258-5530 . FAX: 732-417-0015

SOUTHLAND TOOL MFG. INC.

Building Innovative Tools for Municipalities



Carbide Concave Saws. These special heavy duty saws are made for periods of continued use in situations where tough and aggressive cutting and ripping is required. The carbide teeth are positioned every 5th tooth on the cutting edge going in and then every 10th tooth on the backside of the saw. Southland offers these saws in sizes from 4" to 12".



Counters: 229-3
100 (Deposit Attached Other)
Sawer: 1147
Flow: 42
10"
Remarks: GRIND PRIOR TO CUTTING



Counters: 229-5
100 (General Observation)
Sawer: 1147
Flow: 42
10"
Remarks: GRIND CORE

"Calcium Cutter" Southland tool received these before and after photographs of an 8" line in California. The city used our Diamond Tipped Arrow Cutter as seen on the right. The cutter is for cleaning calcified grease and calcium carbonate deposits. The Arrow cutter attaches to your hydraulic motor and bores into the center of this "Rock Hard" problem and grinds it down until its "gone". Available in 6" to 12". Larger sizes available.

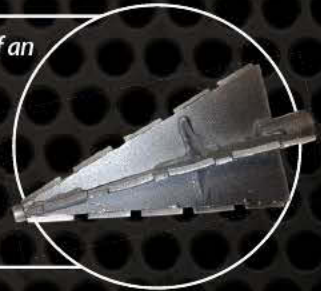

Hi-Torque Hydraulic Root Cutter Motor. This reliable and super strong hydraulic cutter has a 9.1 cubic inch displacement, more than any cutter on the market. This motor grinds and rips through roots, cement, calcium and more. Get ready to bring a lot a material back to the manhole. Combined with our EZ-skids and variety of cutting tools, you will have a arsenal of weapons in your tool box.

Vac-trap. This Patent Pending item is great for sucking up only the debris and leaving the water in the sewer, where it belongs. This products attaches to the end our your suction tube and sits at the bottom of the downstream invert. Our unique design won't get stuck. One the Vac-trap is full just turn on the Vacuum and empty it in a flash and start over. Reduces fuel consumption, decanting time and wear and tear on the suction pump. Available for all type and sizes of suction tubes. For sized from 6" to 24".



Adjustable Top Manhole Roller. This top manhole roller is unique in that it has two opposing clamps that grab the manhole ring from underneath. Since the roller is adjustable you can extend to clamps and create a fixed in place roller that won't "flip out".

Southland tools also carries a large inventory of other items including:

- SEWER RODS • DEBRIS BASKETS • GRABBERS • HANDY CLAMS • CORKSCREWS • AUGERS •
- NOZZLE EXTENSIONS • HYDRO CUTTERS • SPOONS • DEEP-VAC HOLDERS & more!



OK Champion

- **CABLE PULLERS**
- **CABLE SCRAPPERS**
- **POWER RODDERS**
- **REEL LOADERS**



TSE
INTERNATIONAL, INC.
800-825-2402

www.tse-international.com

SONDE



- Exceptional penetration with a 25 to 30 foot range
- Length: 3.7"
Diameter: 0.85"
- Available in 512Hz, 640Hz, 8kHz or 33kHz
- Rugged design in an impact resistant compound
- Rounded heads and tails prevent hang-ups
- Operates on 1 AAA
- Made in the U.S.A.
- Low price of \$250.00

RYCOM
instruments, inc.

800-851-7347
www.rycominstruments.com

CIPP Technology and Equipment LLC



- *Leasing Options Available*
- *Steam Trucks Built To Order*

Our Steam Systems Reduce Overhead by 50%, and Cuts Curing time by 75%

- >Your Premier Industrial Source for Pipe Lining Equipment
- >Specific to the Cured In-Place Pipe Lining Industry
- >Your Steam System Specialist
- >Custom Manufactured Equipment

1.574.259.0903 ■ cipptechnologyandequipment.com



GORLITZ SEWER & DRAIN INC.

Norwalk Blvd. Santa Fe Springs, Ca. 90670

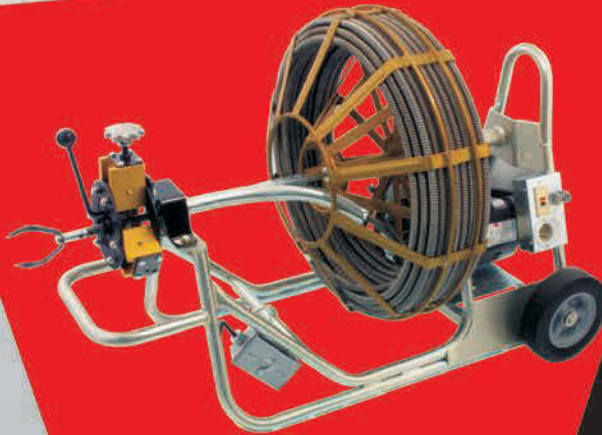

- MACHINES
- FEEDERS
- CABLES
- RAMPS
- CONNECTORS
- LEADERS
- CHUCKS
- ENDS
- RETRIEVERS
- SPLICES
- AUGERS
- JETTERS
- NOZZLES
- HOSES
- TRENCHLESS PIPE SYSTEMS
- SOCKET FUSION KITS

Engineering, Dedication, Quality, Sales and Service All In One Stop!

www.gorlitz.com
Email: sales@gorlitz.com
f GORLITZ on Facebook



Tel: (562) 944-3060
Fax: (562) 944-7630

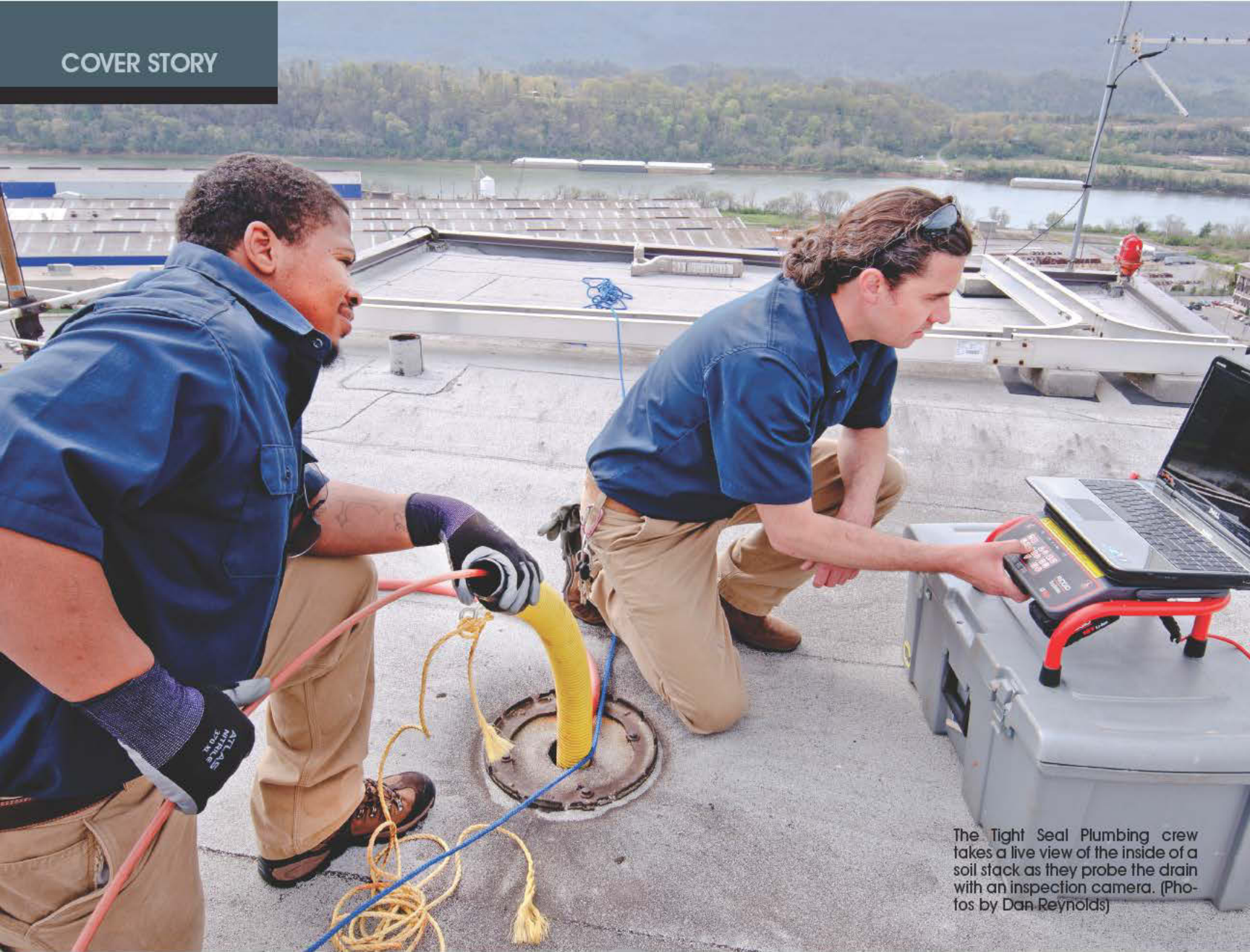

The Tight Seal Plumbing crew takes a live view of the inside of a soil stack as they probe the drain with an inspection camera. (Photos by Dan Reynolds)

Doing the JOB RIGHT

HANDS-ON POLICY HELPS TIGHT SEAL PLUMBING
ESTABLISH A SOLID REPUTATION WHILE STEADILY
GROWING ITS CUSTOMER BASE BY MARIAN BOND

In 2004, master plumber Daniel Baker opened Tight Seal Plumbing in Chattanooga, Tenn., intent on providing high quality plumbing repair and service, but he soon learned there were a myriad of management responsibilities that demanded his attention.

"In those early instances when I brought in another company to do video inspection, I had a chance to view a skilled technician running the camera, and I learned quite a bit. I knew what I wanted to accomplish for my own business."

Daniel Baker

For assistance Baker sought professional help, including a CPA firm to manage accounting, bookkeeping and payroll. There were other growing pains in those first years as well, and Baker hired a licensed master plumber and several plumbing technicians to handle the workload.

"I soon found my strength was not in management, but in serving and interacting with my customers," Baker says. "This means being personally on the job, being present and working on the job. I am able to establish relationships with my customers and ensure they are provided with high quality service and attention to detail."

Currently he works with one full-time employee, an apprentice. He is considering adding more personnel in the future, but for the time being he has quality people available who help on the larger projects. His wife, Brooke, who is co-owner and equal partner, provides regular counsel on the business, and most important, care for their 27-month-old son, Jude Patrick Baker.



Daniel Baker and crew members Danzel Owens and Terry Turner unload equipment for a drain inspection job on the roof of Dogwood Manor, an 18-story high-rise in Chattanooga, Tenn.



Daniel Baker and his wife, Brooke, stand near a Tight Seal service vehicle on location as Daniel and his crew prepare for their next job. A RIDGID JK 3100 Drain Jet and other drain cleaning tools are at the ready in the truck.

profile

TIGHT SEAL PLUMBING, LLC, CHATTANOOGA, TENN.

OWNERS: Daniel and Brooke Baker
 FOUNDED: 2004
 SERVICES: Drain cleaning, jetting, CCTV, plumbing service and repair
 CUSTOMER BASE: Residential, commercial, Industrial

As a small operator, Baker adheres to a schedule that provides time for networking with the accountant, checking inventory and returning phone calls, and he's always available for solving problems. He credits much of his success to a mentor, Terry Turner, a licensed master plumber who is available as a consultant, as well as Edward Combs, Ph.D, his father-in-law, who acts as safety manager in some instances. Combs is also highly skilled with computer technology.

CATCHING THE BIG BREAK

Tight Seal was moving along successfully, contracting out (Baker supervising) whenever a customer required a CCTV inspection, when along came an opportunity in 2011 to take on a major project that would basically pay for advanced CCTV and software equipment. That's when Baker began the research that would steer his small operation in an entirely different direction.

"In 2010 I received a telephone call from CTI Engineers, Inc., a Chattanooga firm," Baker says. "I was referred by the Chattanooga Housing Authority.

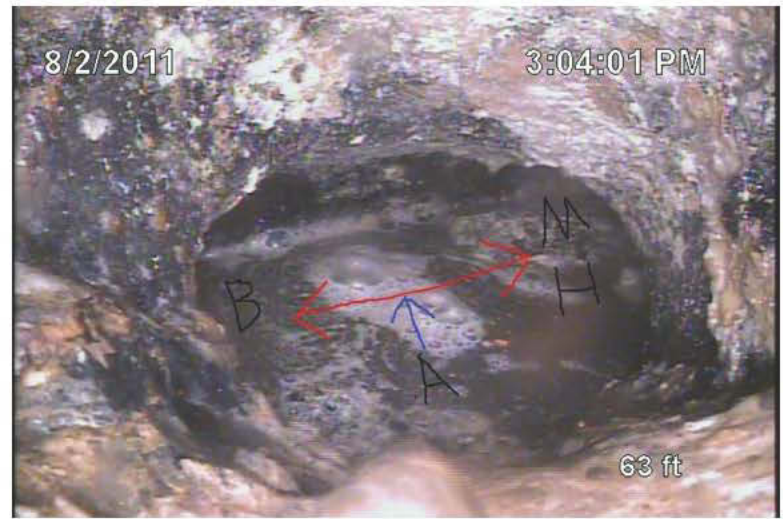

ABOVE LEFT: This image shows a 10-inch concrete storm drain. It is broken, collapsed and appears to have roots, rocks and other debris in it. The drain was over 6 feet deep and lies outside the building foundation. ABOVE RIGHT: The HQ software allows Tight Seal to draw on the still images, among other things. Letters A and B indicate two sewer connections. MH indicates the nearest downstream connection, a manhole serving the sewer main. This image shows a badly corroded 4-inch cast iron sewer pipe connecting with a 6-inch pipe. The larger pipe is holding wastewater due to grease build-up and improper slope. The connection was approximately 7 feet deep. LEFT: Tight Seal set up equipment on top of the 18-story Dogwood Manor and conducted work on the main vent stack. This image is 142 feet from the rooftop, between the fifth and fourth floors. This 4-inch cast iron stack is completely clogged with rust that has flaked off from the pipe walls and dropped below. The vent pipe was no longer venting, and water bugs and roaches had taken up residence. (Photos courtesy Daniel Baker/Tight Seal)

I had previously worked on a project for them. It was an inspection where I had an outside company come in and do the video survey as I did not have the proper equipment, but I managed the job, told them how I wanted it handled. The work made a good impression, and thus the referral.

“In those early instances when I brought in another company to do video inspection, I had a chance to view a skilled technician running the camera, and I learned quite a bit,” Baker says. “I knew what I wanted to accomplish for my own business. I had owned a camera for a while but it had shut down on me in 2009. It was obsolete and it made no sense to have it repaired. So I had to depend on others to service my customers.”

to know what the cost would be and how to budget for it. They required a lot of detail. That was where I came in, to help assess the needs.”

LEARNING THE SYSTEM

The project provided Baker the opportunity to upgrade his own equipment and have it paid off as soon as the job was done. But before he made any decisions, he consulted with Turner. More important, he did his own research.

Baker purchased RIDGID SeeSnake HQ software, a SeeSnake Plus 325-foot Color Reel and continued to learn the many facets of the system, finding it more powerful than he imagined, even as the project was underway.

“Working with their engineer was an experience. We were learning as we were feeling our way through the process of the project. It was exciting to see what [the software] would do and we wanted to push it to the max.”

Daniel Baker

The job CTI was dealing with, Boynton Terrace, was a community of four buildings that provided housing for low-income seniors. There were three 10-story buildings and a two-story community center, all built in the late ‘60s and early ‘70s. The cast iron plumbing was in rough shape.

“They were having consistent problems with sewer backups,” Baker notes. “We were going to figure out what was going on and what was needed. They wanted to do a significant upgrade to all four buildings and needed something concrete to work with when putting their numbers together in order to plan accordingly. The housing authority needed to renovate and/or remodel and needed

“My wife Brooke was at the time working toward her master’s in occupational therapy, and going to Nashville frequently on the weekend to study and I would go with her,” Baker says. “While there I would use my computer to do research on the system. I would take care of my service business and the project during the week, and spend my time there editing and learning about the software, plus reviewing the videos taken the previous week.

“I was able to do much more and in greater detail than we had agreed to in the contract,” Baker continues. “Working with their engineer was an experience. We were learning as we were feeling our way through the process of the project.

It was exciting to see what [the software] would do and we wanted to push it to the max.”

Baker also added a RIDGID KJ-3100 gas-powered cart jetter (3,000 psi/5.5 gpm) to clean the drains on this project.

“Having the jetter I found is almost always the best way to clean the pipe,” he says. “You can get PVC pipe pristine – like a brand new drain. It is amazing. With the older cast iron or clay pipe you can only do so much, but you can get a better idea as to what is going on. You run the camera first, send in the jetter, then run the camera again.”

They had one month to complete the survey for CHA, but time-wise it took about two weeks, working with Turner and Combs (who basically helped muscle equipment for him) and his apprentice, Danzel Owen.

Baker says the finished product provided detailed plans showing location of the lines, condition in certain areas, and problem spots that needed the most attention. They started out with very rough drawings, all the housing authority had on hand. They finished with a full set of detailed plans, and the project went forward with appropriate contractors.

NO EASY CALL

Making the decision to purchase advanced CCTV equipment in order to secure a contract with a major engineering firm was not a simple call for Daniel Baker and his wife, Brooke.

“We thought about it for weeks, and we prayed about it,” Baker says. “I was reticent about jumping in with both feet. There was always the possibility somebody would change their mind, that someone would say ‘We won’t move forward with this.’ I had never worked with the engineering firm before. On a previous job for Chattanooga Housing Authority I had been paid within a week. With the proposed job, we would be investing a lot of money and not be paid that promptly. We would have a lot of money tied up. My wife and I were very concerned.”

The couple, with their small operation, decided they would go forward with the purchase, including a cart jetter, hoping all would work out.

“I did hold off buying the equipment until the last minute,” Baker says. “Until we were signing the contract – I gave them plenty of opportunity to back out.”

While the camera equipment performed beyond expectations, it was the addition of the cart jetter and how it benefitted the overall business that surprised Baker.

“I had never owned a jetter before,” he says. “It’s been awesome for us. This is mobile, great for small drains. I find that jetting a line with the right nozzle is the best way to have a clean pipe.”

“In my business I’m going to do the very best I can for my customer, and having the right equipment is basic. That is my goal – to find the tools that allow me to strive for excellence.”

ANOTHER OPPORTUNITY

When CTI once again had a project with low-income housing in Chattanooga, Baker got the nod and put his equipment to work. The project was Dogwood Manor, an 18-story building also built in the late ‘60s and early ‘70s.

This project offered an entirely different scenario, as the majority of the work was done from the rooftop of the building going down the vent and full stacks. The customer was looking for a general assessment in nine different cast iron stacks, highlighting problems they found and the level of urgency. The 4-inch cast iron pipes on the rooftop transition at the sixth floor and get larger as other services tie in. By the time they are underneath the building and running to the exterior they are 12 to 15 inches and carry both sewage and stormwater.

Baker says they spent five days meeting with housing authority supervisors and the building’s maintenance people and completing the initial inspection.

(continued)

Hannay Reels handle the toughest treatment.

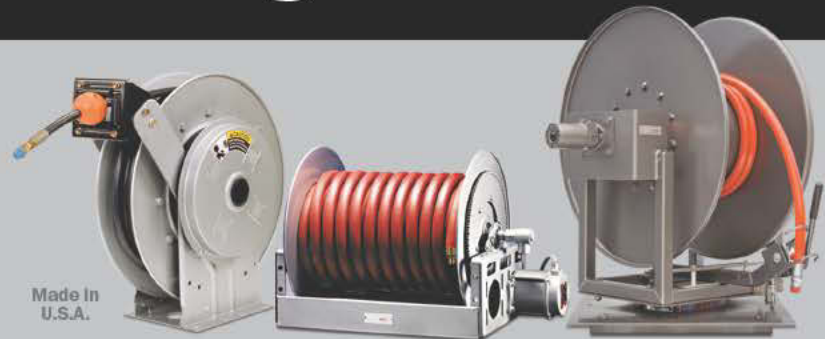

Made In U.S.A.

You face severe conditions every day. We build custom reels that perform even in the harshest environments.

- Built to spec for washdown, jetting, pipeline inspection and more
- Heavy-duty design and construction
- Standard reels ship within a week

Let us solve your reel issues, so your crew can get back to business.



Find your reel solution: hannay.com or 877-467-3357



Hannay Reels®
The reel leader.



Danzel Owens sets up a SeeSnake reel for the rooftop inspection.

They spent one more day jetting and providing additional assessments to get an idea about the viability of the existing pipes, as well as if and how they should be replaced. Owen and Combs were both on hand for the project.

THE VALUE ADVANTAGE

Baker admits that he is still working through a learning curve with the software and discovering new applications. “My interaction with the computer still does not feel 100 percent natural to me. I use it because it is a critical tool that empowers me and allows me to do more in less time. I still use my iPad as much as possible for exterior photos, but the software does not run on the iPad.

“The more I use the new equipment the more comfortable I get with it,” he says.

“Having the jetter I found is almost always the best way to clean the pipe. You can get PVC pipe pristine – like a brand new drain. It is amazing.”

Daniel Baker

Currently his customer base is 60 percent residential and 40 percent commercial/industrial, but he hopes that with the added capabilities this may shift eventually toward a 50/50 ratio.

“With commercial and industrial, the work sells itself,” Baker says. “There is little involved in sales. They call. I show up and do the job. I don’t have to talk it up. I’m getting referrals. That is how it goes.”

He continues to value the residential customer, but those relationships can be much more personal and emotional. “I can appreciate their concerns. We are working on their home. It is a different experience. Plus the residential work is much more physical. Basically though I enjoy the commercial/industrial – it is often more mentally challenging.”

PROPERLY EQUIPPED

Tight Seal operates with a 2005 Chevrolet 3500 box van, which is their workhorse, and a light duty 2006 Chevrolet 2500 Express Van for estimating and small service jobs.

For locating, Baker turns to his Spartan Tool locating wand. He also relies on his time-tested RIDGID K-60 sectional drain cleaning machine in many situations.

The cart jetter has benefitted far beyond expectation, and Baker has no hesitation in presenting this option to his residential customers as well as the commercial and industrial. He doesn’t sell the idea of using the jetter, which does increase costs, but instead explains the problem and what needs to be done. There is a certain comfort level and rapport with customers because most come as referrals.

“I’m going to do whatever needs to be done to correct the situation,” Baker explains. “I’m going to give the best I possibly can. The customer has entrusted me to do that. We need to strive in the industry for that excellence.”

For every job, he encourages video inspections before and after drain cleaning to identify the nature of the problem and con-

firm the success of the cleaning, and if necessary to identify the need for additional work.

TURNING IT AROUND

“Having the SeeSnake HQ capability has enhanced my response time, which is essential for a small company,” Baker says. “I had a phone call recently from a restaurant late in the day. They needed an assessment as they had a problem. I get to the job, and the drain is collapsed. I sent the camera in to inspect, found the problem, came home, edited the video and sent three 10-second clips to the client showing three different problem areas, plus some videos of the locating results. By the time I was done that evening they had everything they needed pertaining to the work and what needed to be done. I did not have to meet with them to hand them a disc. The next morning we had an intelligent and full conversation about the project. With new technology and the right software you can do that.”

With the addition of the new software and capabilities, and opportunities for even a small company to advance into lofty fields, Baker has realized the significance and benefit of providing highly specialized technology. He also sees the value it has added to his business.

“These tools have created a new niche in the sewer inspection market,” Baker says. “I’ve learned I can set myself apart from the competition with the depth of detail the customer needs. I’ve also found ways to better utilize my God-given ability to think critically, problem solve, investigate and trouble shoot.”

more info

RIDGID
800/769-7743
www.ridgid.com
(See ads pages 7, 47)

Spartan Tool, LLC
800/435-3866
www.spartantool.com
(See ad page 96)



We've taken convertible water jet horsepower to a whole new level: 1,000 hp

NLB extends its leadership in convertible water jetting

The new NLB 1005 Series water jet units give you more flexibility than ever before, combining 4,000-to-20,000 psi convertibility with the power of 1,000 hp. These rugged units offer the same reliability, easy maintenance and low operating cost as our 22 other convertible units, and use many of the same parts.

Only the NLB 1005 Series has the horsepower you need for big water jobs AND 30-minute changeover to do everyday jobs. See the 1005 and the rest of the industry's biggest range of convertible units at www.nlbcorp.com, or call **877-NLB-7988**.



The NLB 1005 is the industry's first 1,000-hp water jet unit.

 **NLB Corp.** *The Leader in Water Jet Productivity*

29830 Beck Road, Wixom, MI 48393 • www.nlbcorp.com
MI: (248) 624-5555, IN: (219) 662-6800, NJ: (856) 423-2211,
LA: (225) 622-1666, TX: (281) 471-7761, CA: (562) 490-3277
e-mail: nlbmkgt@nlbusa.com

PRO-VAC INDUSTRIAL PUMPOUT UNIT

IDEAL FOR GREASE TRAP PUMPING



Constructed of **LIGHTWEIGHT ALUMINUM**
Extremely Quiet
Easy to Maneuver
Easy to Use
Easy to Maintain & BUILT TO LAST

Simply The **BEST!**



Westmoor Ltd.

Manufacturers of



Vacuum Technology

800-367-0972

www.westmoorltd.com

YOUR SOURCE FOR RIDGID

CENTRAL OKLAHOMA

Winnelson

COMPANY

8% ONE YEAR FINANCING AVAILABLE!
 Longer lease rates also available. Call Keith for details.

BUYING A SEESNAKE?

**CALL US FOR
 GREAT PRICING &
 FREE SHIPPING!**

**WE
 WILL NOT BE
 UNDERSOLD**

- Call Us Evenings and Weekends -
 Keith: 405-602-9155 &

Jim: 405-205-3974



micro CA-100
Inspection Camera



CS10
Digital
Recording
Monitor
with Flash Drive



LT1000 Laptop
Interface System



microDrain Reel



DVDPak



SeeSnake® MAX rM200
Camera System

CALL TOLL FREE: 888-947-8761

5037 NW 10th
 Oklahoma City, OK 73127

www.centralwinnelson.com

ARE YOU GETTING ALL THE VACUUM POWER YOU EXPECT ?



AllVac

SPEND MORE TIME WORKING

WITH GREATER VACUUM POWER AND RELIABILITY



Twin cyclone pre-filters remove wet and fine dry materials before they reach the bag house.

GREEN
THAT WORKS

Vacall's AllVac industrial vacuum machines deliver more years of higher performance, setting a new long-term productivity standard for the removal of dust, powders, solids, liquids and even thick slurries. Superior filtration effectively cleans air before it reaches the heavy duty blower, protecting the environment while creating maximum vacuum at 27" Hg and maximum air flow at 5760 CFM. Like all Vacall machines, AllVac models require just one engine to slash fuel consumption, emissions, noise and maintenance. Ready to increase your industrial vacuum performance? Call Vacall at 800-382-8302.

LEARN ABOUT THE VACALL VACUUM POWER ADVANTAGE ▶

VACALLINDUSTRIES.COM/VACUUMPOWER



VACALLTM
INGENUITY AT WORK

(800) 382-8302
www.VACALLINDUSTRIES.COM

ALAMO GROUP
GRADALL



MAKEAMERICA.COM

No-Suit Solutions

MEDIATION PROVIDES A PRIVATE, LOW-COST OPTION FOR RESOLVING BUSINESS DISPUTES

BY FRED S. STEINGOLD



Fred S. Steingold practices law in Ann Arbor, Michigan. He is the author of Legal Guide for Starting and Running a Small Business and The Employer's Legal Handbook, published by Nolo. Legal strategies may vary depending on the state in which you live and the specifics of your situation. See your lawyer for legal advice.

Legal disputes can cost you money, create ill will, try your patience, and gobble up tons of your time. Fortunately, you can resolve most disputes without the hassle of a lawsuit. You can use mediation in which a neutral third party helps both sides reach a voluntary solution.

Over the life of your business, you'll probably face at least one legal dispute – and perhaps more. The dispute may be between your business and a customer or client. It may be between your business and a supplier or employee. Or it may be between you and other owners of your business.

Ideally, you and the other side can come to terms on your own. But maybe, despite your best efforts, you and the other person or company can't amicably settle the matter.

When that happens, either mediation or arbitration may be successful. Both methods use a neutral third party in finding a solution. There's a major difference, however: In arbitration, an arbitrator imposes a binding solution on the parties – one that can be legally enforced. By contrast, in mediation, a mediator helps the parties come up with their own solution.

And here's an amazing statistic: Mediation succeeds in over 80 percent of the disputes in which it's used.

CONSIDER THE ADVANTAGES

Let's look at the advantages that mediation offers, courtesy of Peter Lovenheim, a mediation pioneer:

- *You control the outcome.* If you reach a settlement through mediation, it's because you and the other party have agreed on the terms. A judge, jury, or arbitrator hasn't dictated the outcome.
- *You control the process.* The parties select the mediator and decide which issues will be covered and how costs will be allocated.
- *You save on legal fees.* In a court case, you typically need a lawyer – in part because lawsuit procedures are complicated. Legal fees can mount up rapidly. In mediation, if you use a lawyer at all, you'll be billed for a relatively small number of hours.
- *You can intelligently address technical issues.* In a courtroom, the judge or jury may not understand some technical issues. In mediation, you can call in a mediator who has the technical background to properly analyze your dispute.
- *You control the timing.* Rather than being at the mercy of court dockets and lengthy adjournments, the parties who choose to mediate can work out a speedy time schedule. Your dispute needn't drag on endlessly.
- *You avoid unwanted publicity.* A lawsuit is public. Mediation is private. The world won't learn about business mistakes, internal problems or trade secrets. Explosive allegations by an employee, for example, can hurt any business – but not if these allegations are confined to the privacy of the mediation room.

- *You can preserve relationships.* Going to court tends to harden people's attitudes. Not so with mediation. There's a good chance that the relationship – whether with a customer, supplier or employee – will outlast the dispute. This may be the biggest benefit of all.

In arbitration, an arbitrator imposes a binding solution on the parties – one that can be legally enforced. By contrast, in mediation, a mediator helps the parties come up with their own solution.

GETTING STARTED

If your dispute grew out of a written contract, perhaps the contract says that you'll mediate any dispute before going to court or to an arbitrator. But even if you haven't agreed to mediation in the contract – or if there is no contract – you and the other party can agree to mediate. In fact, even if the case is already in court, you can still try mediation.

You can find a mediator through organizations such as the American Arbitration Association or through a dispute resolution center in your community. You may want a mediator with specialized knowledge. For example, if you have a construction dispute, you may want to find a mediator who understands construction issues.

But generally, special knowledge isn't essential for a successful mediation. Most mediators are quick studies who can easily come up to speed on technical issues.

HOW MEDIATION WORKS

The mediator starts by outlining the procedures you'll be following. Then each party makes an opening statement. You'll explain your position and how you'd like to see the dispute resolved.

Next, you and the other party will discuss the dispute face-to-face. The mediator will ask questions and offer comments. At some point, the mediator will meet separately with each party and may carry settlement proposals back and forth between the opposing camps – a sort of shuttle diplomacy.

As needed, the mediator gets everyone back together in one room for face-to-face discussions. When the parties agree on settlement terms, the mediator drafts a settlement agreement reflecting those terms, and both parties sign it.

For more information, consult Peter Lovenheim's excellent book, *How to Mediate Your Dispute*. **c**



The Emerson logo is a trademark and service mark of Emerson Electric Co. ©2013, RIDGID, Inc

Getting to the problem won't be a problem.

It's compact for easy storage...lightweight for easy transport... and versatile for easy use. The SeeSnake® microReel System from RIDGID® is the perfect solution for inspecting lines up to 4" in diameter and 100' in length. Getting to the problem has never been easier.

Learn more and schedule demonstrations:
800.769.7743 or RIDGID.com



Modular Monitor Platform



Digital Recording



Optional Distance Counter



RIDGIDConnect™ Enabled



100' REACH

We Build Reputations™

RIDGID

EMERSON
Commercial & Residential Solutions

Make More Money

ESTABLISHING A SUCCESSFUL CCTV INSPECTION PROGRAM TAKES CAREFUL PLANNING, ATTENTION TO DETAIL AND PLENTY OF HARD WORK

BY JIM AANDERUD



Pipeline inspection programs vary from contractor to contractor. Some are very dynamic and achieve remarkable productivity, while others are mired in mediocrity. By understanding the characteristics that make up a successful CCTV inspection program, you can identify critical points that can help serve as a guide.

Let's begin by establishing the definition of a successful CCTV inspection program. It is first and foremost based on the quality of the recorded videos and on the accuracy and usefulness of the information gathered. Since critical and costly decisions are based on these factors, it is imperative that the video and data be of the highest possible standard.

Another critical component of a successful CCTV inspection program is the quantity of video inspections produced within a stated period of time. This measurement is most commonly defined by the total number of feet inspected in a day, month or year. It is generally referred to as production.

Most contractors justify the purchase of their CCTV inspection unit(s) based upon projected production. The outlay of capital was deemed reasonable because of the anticipated footage that crews would be able to inspect. Achieving these daily footage goals would justify the expense of the vehicle.

The outcomes of these decisions aren't usually realized until much later. While most inspection programs reach their stated goals and achieve success, many struggle and eventually fail. For those who fall short, the justification to purchase a CCTV inspection van was flawed. Testaments to this fact are the numerous inspection vehicles being offered for sale by contractors. Most of these vehicles operated for only a short period of time, and most all of them failed because of a lack of production.

For a contractor, a pipeline inspection van must be able to make enough money to pay its expenses and to also generate a reasonable profit. Since its income is directly linked to the number of feet it inspects, a priority must be placed on production. If footage goals are not met, the unit will lose money and eventually fail.

WHY DO CCTV PROGRAMS FAIL?

The number one reason CCTV inspection programs fail is because an unqualified individual is selected as the CCTV inspection operator. The skills required to succeed as an operator are very important and must be thoroughly evaluated during the hiring process. Finding an individual with strong computer and mechanical ability is key. Leadership and organizational skills are indispensable, as is dedication and a can-do attitude. Anyone short of an ideal candidate will doom the inspection program from the onset.

Inspection programs also fail due to a lack of training. Operators must be given the tools to succeed. A few days of factory training and a few days of NASSCO PACP training may not be sufficient. Having a qualified trainer to thoroughly prepare a pipeline inspection operator will increase the chances of success.

HOW CAN WE ENSURE HIGH PRODUCTION LEVELS?

CCTV inspection operators will not succeed without good time management skills. Each day must be a process of planning and exercising conscious control over the amount of time spent on specific activities in an effort to increase effectiveness, efficiency and productivity.

<< Using time effectively and being ready to inspect the next section of pipe as quickly as possible after getting to the site is one of the keys to an effective inspection program.

I once had the opportunity to observe a low production crew. Even though they arrived at work at 7 a.m., the first pipeline wasn't inspected until well after 10 a.m. To begin with, there was absolutely no hurry to leave the yard. Once mobilized, there was a rendezvous at the local donut shop that lasted much longer than necessary. The crew finally headed to the job site, arriving at 9 a.m. After taking their time to set up traffic control, there was the realization that the manhole hook was missing, so they returned to the yard to get one. That morning, they inspected two sections of pipe. The crew then went on to exceed their allotted time for lunch and wound up with the same dismal numbers for the afternoon. With a miserable amount of pipeline inspected that day, it was clear that this inspection program was doomed.

CCTV inspection operators will not succeed without good time management skills. Each day must be a process of planning and exercising conscious control over the amount of time spent on specific activities in an effort to increase effectiveness, efficiency and productivity.

Success in any job comes from a sense of urgency in performing the work. This is certainly the case in the field of pipeline inspection. An operator must constantly push ahead in an effort to accomplish as much as possible. Tasks that can be done right away should never be left for later. Ultimately, an effort must be made to fit as much as possible into each moment of the day.

From the moment you clock in to the moment you clock out, you are being paid to perform your work. As a pipeline inspection operator, you are expected to spend as much time as possible inspecting pipe. Any time that is directed elsewhere is unproductive.



One way to increase efficiency is to identify and set up the next inspection while the crawler is being brought back to the access manhole.

Time is often deliberately wasted in order to minimize actual work. The term I like to use for someone who intentionally milks the clock is a "time thief." As harsh as this may sound, this is exactly what is happening when an employee is avoiding work for which he is being paid.

Using time productively starts at the beginning of each day and must be

carried through to the last minute. We must ensure that non-productivity is held to an absolute minimum. It begins with getting out to the job site as expediently as possible. It means planning ahead to ensure everything you need is on the vehicle. It means carrying out your plan in the most efficient manner possible. It means leaving nothing to chance. The bottom line is you must work as methodically as possible in order to maximize production.

You must eliminate non-productive actions. Aimless chatter, private phone calls, texting and Internet surfing are all examples of lost opportunities. Anytime work comes to a standstill takes away from your production potential. Operating a CCTV inspection unit is not physically demanding, so there is absolutely no reason to stop and rest or sit with nothing going on.

Being proactive is the key to a productive day. By planning ahead, you can take deliberate actions to ensure all time is used to its fullest. A lack of planning results in wasted time as work comes to a halt while the next step is deliberated.

TIME BETWEEN INSPECTIONS

In order to maximize production, you must reduce the time spent in between inspections. Whether you are working alone or with a crew, the more effective system you have for getting from manhole to manhole, the higher the production rate will be.

When a survey is completed and the crawler has returned to the access manhole, it must be retrieved, washed down and placed into the van as quickly as possible. At the next location, manhole lid removal and crawler insertion must be done cautiously but urgently. Every action must be performed as expediently as possible in order to maximize inspection time.

Multi-tasking is a very useful way of capitalizing on our time. By performing more than one task at a time, production can be accelerated significantly. For example, while the crawler is being brought back to the access manhole, the next survey can be identified and set up on the computer. This will ensure that the next inspection begins the moment the crawler hits the bottom of the next manhole.

If not managed properly, traffic control can affect a crew's productivity as well. When support staff is available, crew members should move ahead and place traffic control devices ahead of time. This will allow the inspection van to move right in, drop the camera and begin recording immediately. When long continuous stretches of pipeline are encountered, laying out the traffic control devices over multiple setups can help increase productivity.

Your time in the field is limited, so managing it effectively is the key to maximizing the number of pipeline inspections you perform. Achieving high production levels will ensure that your inspection programs are successful and that your companies run profitably for many years to come. ©

ABOUT THE AUTHOR Jim Aanderud is owner of Innerline Engineering, a video pipeline inspection company based in Corona, Calif.



SPIR STAR®

SILVER MONGOOSE
SPIR STAR
TYPE 5/5H
MADE IN GERMANY
BATCH NO. 7360

**Proven Products
Proven Solutions**

Specialists in High Pressure
Hose | Fittings | Adapters
Quick Disconnects | Valves

www.spirstar.com
Toll Free: 800.890.7827 • Fax: 888.893.1255
ISO 9001:2008 Certified

© SPIR STAR 2013



LADTECH System™
HDPE MANHOLE ADJUSTING RINGS

The "LADTECH System™" is the only manhole grade adjustment system made in the USA from 100% Recycled Plastic Polyethylene also acquired in the USA. Ladtech's HDPE manhole adjustment rings provide a proven alternative to concrete grade or adjustment rings and is the most advanced alternative manhole grade adjustment system available anywhere. The material is renowned for its ability to stand up to the harshest of conditions without damage or deformation for generations.

EFFICIENT - One man can easily install the LADTECH SYSTEM™ in minutes. The rings nest together including a finish spacer ring and a 2% slope adjustment ring for a precision fit.

SAFE - It usually takes four men to lift and place a concrete grade ring, which break and can cause back and bodily injury, the LADTECH SYSTEM™ eliminates that hazard, helping reduce comp claims. A 4" HDPE Ladtech Ring only weigh 9 pounds.

COST EFFECTIVE - LADTECH™ products speed manhole installation and repair efficiently, allowing the site to be closed in one day and reducing overall cost from 20% - 30% or more, based on conditions. No water, mortar or bricks are needed, just a few simple tools.

Follow LADTECH, INC. on FACEBOOK!
877-235-7464
www.ladtech.com

We are looking for Distribution in these states: PA, NJ, TN, GA, NE, CO, NM, AZ, UT

ultra ultra ultra
LIGHT - VERSATILE - SAFE

ultraSHORE
P R O D U C T S



Quick to Install.
As light as 130lbs.

Roll Your Own.
Optional wheel kit.

Stacks easily with
2' & 4' high panels.

This is What Aluminum Shoring Was Meant to be!

SCA
SAFETY CORPORATION OF AMERICA

1-800-SHORING
CALL TOLL-FREE NATIONWIDE • 1-800-746-7464
www.shoring.com

1-800-683-8837

CIPP
La Salle, Illinois Services, Inc.



Complete System
\$ 21,995.00

Continuous Air Inverter With Adapters For 6" to 18" CIPP Liners; Includes "B" Steam Station.

- Steam & Hot Water Boiler Trucks
- Static Resin Mixers
- Wet-Out Tables
- Improved Cutter Systems
- 53' Reefer - Hydraulic CIPP Liner Unloader Trailers

Phone: 815 - 712 - 8708 Fax: 815 - 220 - 1918
E-Mail: sales@cipp-services.com

www.CIPP-SERVICES.COM www.FASTPIPELINING.COM

**Winter will return.
Be ready.**



MyTana's Cold Weather Package

Gives you all the tools you need to melt away ice and hardened blockages, including the HotBox and MY30 mainline gas jetter.



Request your
FREE, FULL LINE
catalog today!
800.328.8170

1.800.328.8170

**Factory Direct
Customer Service**

Competent • Polite • Clear
(M - F 7 am-5 pm CST)







MyTana

Professional grade tools for sewer & drain professionals

www.MyTana.com

CABLE MACHINES • JETTERS
PUSH CAMERAS FOR MAIN LINES
& DRAIN LINES • LOCATORS
RELATED PARTS • ACCESSORIES

Forbest Inspection Camera Systems—As low as \$450⁰⁰!

Long Range Pipe Inspection Camera	Mid-Range Pipe Inspection Camera	Luxury Portable Sewer/Drain Camera
<p>FB-PIC3288T/3488T</p> <ul style="list-style-type: none"> • 300FT/400FT Cable & Reel w/Meter Counter • Self Levelling Camera Head w/Built in 512HZ Sonde Transmitter • 10 inch LCD Monitor w/DVR & MIC • Heavy Duty Waterproof Case • Option: upgrade to Wireless Inspection System 	<p>FB-PIC3388MT</p> <ul style="list-style-type: none"> • 200FT Cable & Reel w/Meter Counter • Self Levelling Camera Head w/Built in 512HZ Sonde Transmitter • 10 inch LCD Monitor w/DVR & MIC • Heavy Duty Waterproof Case • Option: upgrade to Wireless Inspection System 	<p>FB-PIC4188</p> <ul style="list-style-type: none"> • 130FT Cable & Reel • Color Camera Head w/Built in 512HZ Sonde Transmitter • 10 inch LCD Monitor w/DVR & MIC • Heavy Duty Waterproof Case • Option: upgrade to 130FT Cable & Reel w/Meter Counter (NEW) 
Portable Sewer/Drain Camera		New Products
<p>FB-PIC3188DN</p> <ul style="list-style-type: none"> • 65FT/100FT/130FT Cable & Reel • Color Camera Head • 7 inch LCD Monitor w/DVR & MIC • Heavy Duty Waterproof Case • Option 1: upgrade to Color Camera Head w/Built in 512HZ Sonde Transmitter • Option 2: upgrade to 130FT Cable & Reel w/Meter Counter (NEW) 	<p>FB-PIC3188D</p> <ul style="list-style-type: none"> • 65FT/100FT/130FT Cable & Reel • Color Camera Head • 7 inch LCD Monitor w/DVR & MIC • Aluminum Case • Option 1: upgrade to Color Camera Head w/Built in 512HZ Sonde Transmitter • Option 2: upgrade to 130FT Cable & Reel w/Meter Counter (NEW) 	<p>Forbest New Powerful 512HZ Sonde Transmitter</p> <ul style="list-style-type: none"> • Frequency: 512HZ • Max distance: 20FT • Dimension: Diameter: 1" (22mm), Length: 2 5/8" (65mm)  <p>Forbest Ultrasonic Leak Detector Kit (Pinpoint the exact location of the leak point quickly)</p> <ul style="list-style-type: none"> • Frequency Response: 36KHZ-44KHZ (Centered at 40KHZ) 

315 Harbor Way, #B, South San Francisco, CA 94080
Tel: 650 757 4786

www.forbestusa.net
Email: forbestusa@gmail.com



VSI Rentals, LLC.

51 Stone Road Lindenwold, NJ 08021
888-VAC-UNIT Fax: 856-627-3044



2008 Sterling truck mounted combination vacuum and jetter units
3 Available
Price by Request

**ALL UNITS AVAILABLE FOR
RENT OR PURCHASE
888-VAC-UNIT**



2008 Condor, dual steer truck mounted, large capacity sweeper with dual sweep gear and catch basin cleaner unit
Price by Request



2008 International truck mounted, industrial wet/dry vacuum loaders with 27" Hg blowers
2 Available
Price by Request



2006 GMC (very low mileage) truck mounted high pressure jetter unit with TV inspection and vacuum system
Price by Request

Scan the QR code with your smartphone



The Most Complete and Economically Priced Pipe Lining System Available Today

"Specializing in Pipe Lining Systems for Inside & Outside of Buildings"

One Trailer Does It ALL!

FLOW-LINER® BASIC TRAILER SYSTEM

Value Priced



- 2" to 8" Air Inversion Pipe Lining System
- Flow-Liner Robotic Cutting System

THE FLOW-LINER® ROBOTIC CUTTING SYSTEM

A complete cutting system for pipes from 2"-10" diameters. A better more versatile cutting system for less money than the competition!



Why Choose The Flow-Liner® Cutting System?

- Ability to do 2" to 10" pipe diameters
- More compact and easy to maneuver
- Positions in place in vertical & horizontal pipes
- See through design cutter blades
- Adjustable cutter speeds
- Better camera visibility

Value Priced

Contact a Flow-Liner® Sales Representative today to find out how we can solve all your Pipe Lining needs!

In USA Toll-Free: 800-348-0020
International: 1-740-453-9387
email: info@flow-liner.com
website: www.flow-liner.com



PROFESSIONAL PIPE LINING

The Cost of Excavation Safety

TAKING THE PROPER PRECAUTIONS IS THE BEST THING FOR YOUR EMPLOYEES
AND YOUR COMPANY'S BOTTOM LINE

BY DOUG DAY

Every time you dig a trench, you are putting workers at risk. As the trench gets deeper, the risks get higher and the more management practices are needed to make sure the trenching is being done safely.

Two workers are killed every month, on average, in trench collapses in the U.S., according to OSHA. The agency cites "economic pressures, a belief that compliance is unnecessary or an expectation that these short-term operations will go undetected" as key reasons why regulations are not followed, even after years of emphasis.

Any trench 5 feet or deeper requires a protective system: benching, sloping, shoring, or shielding. If the trench is less than 5 feet deep, a "competent person" could determine that a protective system is not needed. A competent person is one who has been trained in such things as soil classification, water content of the soil, and other matters that could pose a risk to trench integrity. Protective

Imagine having to deal with that: the fines, civil liability, bad publicity – having to notify the worker's family that they will never see their loved one again.

systems in trenches of 20 feet deep or greater must be designed by a registered professional engineer or be based on data prepared or approved by one. (A trench wider than 15 feet falls under excavation regulations)

Workers must also be provided safe access methods. Such ladders, steps, and ramps must be within 25 feet of all workers in any trench of 4 feet or deeper. The regulations include several other provisions, such as regular inspection (by a competent person), keeping heavy equipment away from trenches, storing spoils at least 2 feet from the edge, atmospheric testing, and suspended/raised loads safety.

Beyond safety of workers, there are practical business reasons for proper trenching practices. A Philadelphia plumbing company was hit with more than \$40,000 in fines in April for excavation violations while installing a residential sewer line. The OSHA violations included the lack of a protective system, no barrier for the spoil pile, inadequate training, and failure to have a hazard communication program.

Making matters worse, three of the violations were repeat events, escalating the enforcement action and accounting for \$36,960 in fines. Four were ranked as serious, which added another \$3,520 for a total fine of \$40,480. That's an expensive bill for shaving a few minutes off a job.

The violations could also have resulted in serious harm, or death, for the workers. Imagine having to deal with that: the fines, civil liability, bad publicity – having to notify the worker's family that they will never see their loved one again.

Besides posing the greatest risk, cave-ins are the most common accident involving trenches. One cubic yard of soil weighs as much as a car (a 1-ton dump truck carries roughly five cubic yards). Other risks include falls, falling loads, accidents with moving equipment, underground utilities, and even hazardous atmospheres.

While the onus for safety falls on the employer, workers are their own best protection. As an OSHA trench safety poster states, "An unprotected trench is an early grave."

ONLINE RESOURCES

Half of the states are covered by OSHA's regulations, 25 others have adopted their own standards (as have Puerto Rico and the Virgin Islands). Most state standards are identical to OSHA's, but some have other standards. Learn more at www.osha.gov/SLTC/trenchingexcavation/index.html.

OSHA ETOOL

www.osha.gov/SLTC/etools/construction/trenching/mainpage.html 

Need Jetting Hoses?



Jetting/Lateral Line Hoses

Large Diameter Hoses Up To 1-1/2"

Piranha® Standard High Pressure Sewer Cleaning Hoses

Piranha Armor Belt® Sewer Cleaning Hoses

Piranha® Slither™ High Pressure Sewer Cleaning Hoses

Twin/Multi Lines

For samples, literature and more information contact us at



Piranha Hose Products, Inc.,
Cadillac, MI

1-800-250-5132

www.piranhahose.com

GO WHERE NO OTHER TRUCK SYSTEM CAN GO!

COMPACT, EASY-TO-USE SYSTEM FOR PIPE SIZES RANGING FROM 6" - 200"



CUES Wireless Base Station Portable CCTV Inspection System

- Mount in an ATV, Pick-up Truck, Trailer, or Van
- Provides Maximum Protection via an Enclosed Video Inspection System
- Compatible with CUES DUC Digital Universal Side Scanning Camera

The CUES self-contained, enclosed, portable CCTV pipe inspection rig is mounted in a compact, lightweight, rugged, weatherproof enclosure and can fit into an ATV, van, or pick-up truck to access easements and hard-to-reach areas. The unit operates all CUES wheeled/tracked transporters and pan and tilt zoom cameras to accommodate 6" - 200" pipe inspections. Camera options include a built in inclinometer, sonde, or a laser diode system to measure cracks and offsets. Enclosure options include heavy duty welded lifting eyelets or forklift skids for quick deployment to the host vehicle. Contact CUES for a discussion and demonstration!

The Base Station is compatible with the DUC!



"The Standard of the Industry"



www.cuesinc.com
800.327.7791
salesinfo@cuesinc.com

THE CABLE CENTER 1-800-257-7209

MIDWEST'S LARGEST FACTORY AUTHORIZED
REPAIR CENTER FOR GATORCAM, GEN-EYE & SEESNAKE

24
HOUR
TURNAROUND

FREE
DELIVERY
ON ALL RIDGID
CAMERA
KITS

RIDGID's NEW CS10 Digital Recording Monitor

- USB Thumb Drive
- 12.1" Daylight Readable Display
- Multi Mode Recording
take snapshots, record full video & lean video
- Software Integrations
with SeeSnake HQ & RIDGIDConnect™



• THE CABLE CENTER • 8318 OLIVE BLVD. • ST. LOUIS, MO 63132 • 314-993-3099 •

T&T TOOLS

T&T Tools, Inc.

Fax: 800.521.3260

Email: sales@tandttools.com

800.521.6893
www.MightyProbe.com

Call for a FREE Catalog

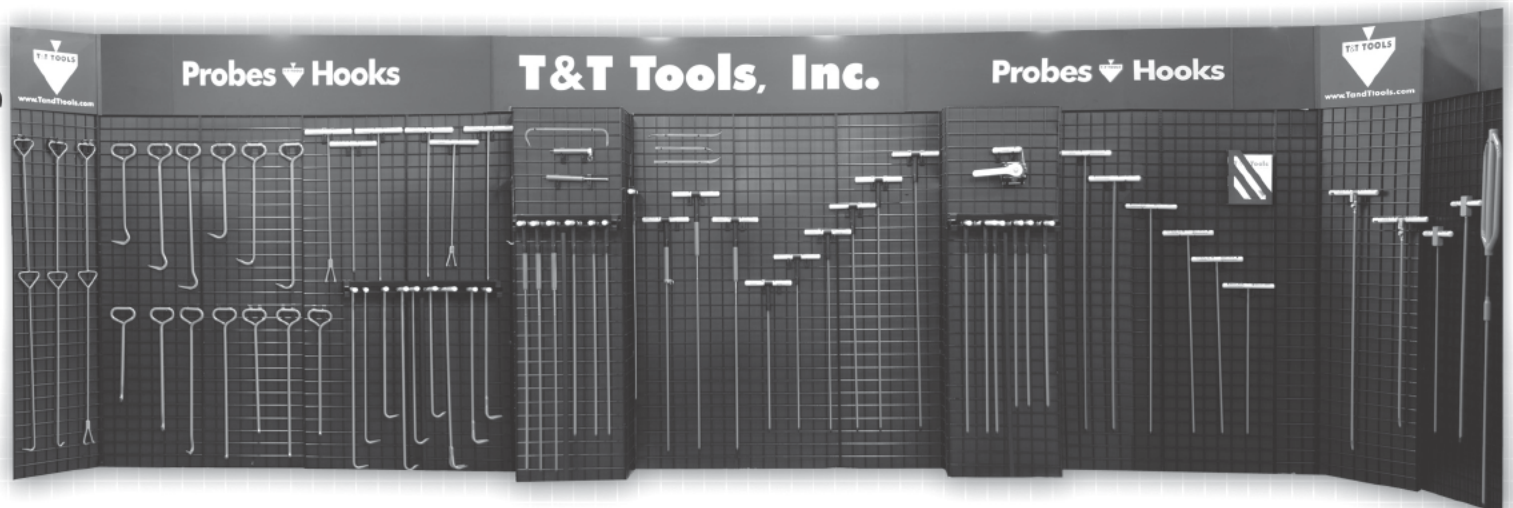

Call for a FREE Catalog

HOOKS...

- > Several different styles of heat-treated hooks are available
- > Top Poppers are great to open manhole covers
- > The Handy Hooks allow two handed use

PROBES...

- > Insulated, standard, and specialty soil probes
- > Metal shaft sizes: 3/8" round, 3/8" hex, or 7/16" hex
- > Replaceable tips are threaded on and hardened
- > A "slide" allows the handle to pound the shaft into the ground



The best just got better!



Supersucker HDX

Offering maximum flexibility, the new Supersucker® HDX performs superior waste removal and bulk material recovery as well as tank cleaning, potholing and other hydro excavating functions.

And it's available with Super Products' latest innovation, the Acculevel™ Load Sensor System.



800.837.9711 • superproductsllc.com

Super Products LLC...Living up to our name.

Cleaner

Waterblasting/Waterjet

COMPANY DIRECTORY 2013

Please tell any of the companies you contact that you saw their listing in the Waterblasting/Waterjet Directory. If you have any questions, please contact COLE Publishing at 800-257-7222 or 715-546-3346. You can also find us at www.cleaner.com.

	Jetter Manufacturer	Jetter Distributor	PRESSURE RANGE			TRANSPORT METHOD			Pump Manufacturer	Pump Distributor	Waterblasting/Waterjet Accessories & Equipment
			Under 3,000 PSI	3,000 to 6,000 PSI	6,000 to 40,000 + PSI	Hand Por table	Truck/Trailer	Stationary			
	Advanced Pressure Systems 701 S Persimmon St., Ste. 85, Tomball, TX 77375 877-290-4277 • 281-290-9950 • (f) 281-290-9952 www.waterplast.pro • dmitche11@advancedprecision.biz										✓
	All Jetting Technologies, Inc. 2740 SW Martin Davids Blvd., Palm City, FL 34990 772-286-1218 • (f) 772-286-0069 www.alljetting.com • info@alljetting.com				✓						✓
See ads on pages 23, 73	Allan J. Coleman Co. 5725 N Ravenswood Ave., Chicago, IL 60660 773-728-2400 • (f) 772-728-2499 www.allanjcoleman.com • info@allanjcoleman.com	✓		✓			✓	✓		✓	
See ad page 65	Amazing Machinery, Inc. 2160 S Lee Hwy., Cleveland, TN 37311 800-504-7435 • 423-472-2527 • (f) 800-504-7436 www.amazingmachinery.com • sales@amazingmachinery.com	✓		✓	✓		✓	✓	✓		✓
See ad page 88	American Jetter 6908 Pine Grove Rd., Knoxville, TN 37914 866-944-3569 • 865-524-4647 • 865-247-5105 andy@americanjetter.com	✓		✓	✓		✓	✓	✓		
See ad page 88	Aqua Blast Corp 1025 W Commerce Dr., Decatur, IN 46733 800-338-7373 • 260-728-4433 • (f) 260-728-4517 www.aquablast.com • davidt@aquablast.com	✓		✓							✓
	Blasters, Inc. 7813 Professional Pl, Tampa, FL 33637 813-985-4500 • (f) 813-985-0127 www.usedwaterblasters.com • info@blasters.net		✓		✓						✓
See ad page 89	Boatman Industries, Inc. 7355 Airport Blvd., Houston, TX 77061 713-641-6006 • (f) 713-644-9345 www.boatmanind.com • info@boatmanind.com		✓		✓	✓		✓		✓	✓
	Cam Spray 520 Brooks Rd., Iowa Falls, IA 50126 800-648-5011 • 641-648-5011 • (f) 641-648-5013 www.camspray.com • sales@camspray.com	✓		✓	✓		✓	✓	✓		
See ad page 44	Central Oklahoma Winnelson 5037 NW 10th, Oklahoma City, OK 73127 888-947-8761 • 405-947-8761 • (f) 405-947-1934 www.centralwinnelson.com • krjones@winnelson.com		✓		✓		✓			✓	
See ad page 88	CESCO/Aqua Miser Boss 7251 Cross Country Rd., N Charleston, SC 29418 800-394-4987 • 843-760-3000 • (f) 843-760-3500 www.aquamiser.com • chris.fulmer@aquamiser.com	✓			✓		✓	✓	✓		✓
See ad page 72	Chempure Products Corp. 148 Canal Ave., Bolivar, OH 44612 330-874-4300	✓		✓	✓		✓	✓		✓	✓

Cleaner

	Jetter Manufacturer	Jetter Distributor	PRESSURE RANGE			TRANSPORT METHOD			Pump Manufacturer	Pump Distributor	Waterblasting/ Waterjet Accessories & Equipment
			Under 3,000 PSI	3,000 to 6,000 PSI	6,000 to 40,000 + PSI	Hand Portable	Truck/Trailer	Stationary			
	Terydon, Inc. 7260 Erie SW, Navarre, OH 44662 330-879-2448 • (f) 330-879-2643 www.terydon.com • sales@terydon.com	✓			✓	✓	✓			✓	
See ads on pages 56, 85	The Cable Center, Inc. 8318 Olive Blvd., Saint Louis, MO 63132 800-257-7209 • 314-993-3099 • (f) 314-432-8024 www.thecablecenterinc.com • thecablecenterinc@gmail.com	✓	✓	✓	✓	✓	✓		✓		
	Triple R Specialty 6925 W Beaver St., Jacksonville, FL 32254 800-356-9661 • 904-786-1826 • (f) 904-786-0911 www.triplerspecialty.com • ram@triplerspecialty.com	✓	✓	✓	✓		✓		✓	✓	
See ad page 83	 TST Sweden AB Prastgatan 12, Kinna, 51154 SWEDEN +46 320 20 58 71 www.tst-sweden.com • magnus@tst-sweden.se									✓	
See ad page 13	US Jetting LLC 850 McFarland Pkwy., Alpharetta, GA 30004 800-538-8464 • 770-740-9917 • (f) 770-740-0297 www.usjetting.com • sales@usjetting.com	✓		✓	✓		✓	✓		✓	
	Vector Manufacturing 1621 S Illinois St., Streator, IL 61364 800-627-3171 • 815-672-3171 • (f) 815-672-2779 www.waterblast.com • sales@vector.com	✓									
	Water Cannon, Inc. 4044 W Lake Mary Blvd., Units 104-424, Lake Mary, FL 32746 800-333-9274 • (f) 888-928-9274 sales@watercannon.com		✓	✓	✓	✓	✓		✓	✓	
See ad page 34	WOMA Corporation 95 Newfield Ave., Ste. K, Edison, NJ 08837 800-258-5530 • 732-417-0010 • (f) 732-417-0015 www.womacorp.com • womacorp@frontier.com	✓			✓		✓	✓		✓	



It's your magazine.
Tell your story.

At Cleaner, we're looking for drain and pipe cleaning and rehabilitation companies with an interesting story to tell. If you'd like to share your story, send us a note at editor@cleaner.com.

THE ELECTRIC EEL® MODEL C DRAIN & SEWER CLEANER...

BEATS THE DRUM!

TRIED & TRUE, BETTER THAN NEW...

This Powerful Sectional Drain Cleaner Outperforms Drum-Style Machines

- Redesigned Quick-Connect Snap-Lock Cable Couplings
 - No Down Time From Broken or Kinked Cables
 - More Power and Twice the RPMs
 - Less Cable and Tool Breakage
 - 8' & 10' Sectional Cables
 - Easy Transport By One Person
 - Lower Maintenance and Much More
 - All For \$100's Less!
- Don't Miss A Beat... Call Today!**

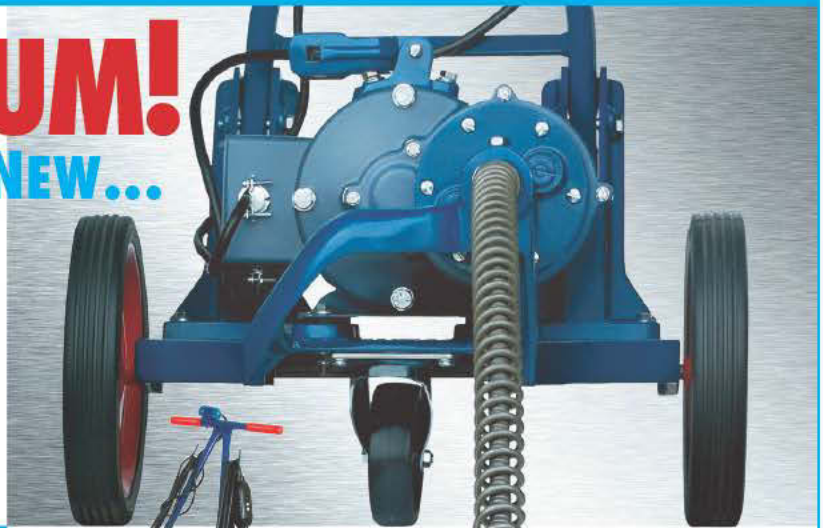

Fold down handle allows easy transport, storage and use in crawl spaces.

Cleans 3"-10" diameter lines up to 200 ft.

Redesigned **Quick-Connect** snap-lock cable coupling allows cables to connect easier and quicker than ever. Now standard on all Electric Eel® sectional dual cables, regular and heavy duty, and totally compatible with all cables currently in use.



PATENT PENDING

Electric Eel®

1-800-833-1212 www.electriceel.com

DRAIN CLEANING TOOLS FOR PROFESSIONALS

Working well under pressure!



GET MORE JETTER FOR YOUR DOLLAR!



STB2712H-MAX

Trailer Jets from \$6699.00

EJT4007H 688 cc Honda 7GPM @ 4000 PSI... \$6699

STB2712H 688 cc, Honda 12 GPM @ 2700 PSI... \$13849

SK3012K 29 h.p. Fuel Injected Kawasaki 12 GPM @ 3000 PSI... \$16299

STB3015V 35 h.p. Briggs Vanguard 15 GPM @ 3000 PSI ... \$19299

GW4018DT 66 h.p. Kubota Diesel 18 GPM @ 4000 PSI... \$41900

Van and Truck Mounts starting at \$4995.00

www.camspray.com

800-648-5011

We Have ALL Your Sewer Needs



Blowers



Hose & Couplings



GasAlert Systems



Gloves



Tripod Systems



Protective Coveralls



First Aid Kits



Safety Clothing



Hose Ramps

RESPIRATORS • RAIN GEAR & BOOTS • HARD HATS & FACE SHIELDS
TRAFFIC SAFETY • HEARING PROTECTION • SAFETY GLASSES

Call For A FREE Catalog Today!



1.800.325.3730

www.MilwaukeeRubber.com

WE JUST COULDN'T LEAVE RELIABILITY ALONE.



There's plenty to love in the new Guzzler Classic.

That's because it was designed with input from our customers. It's full of new and enhanced features that come in handy for easier operation, hassle-free maintenance and added safety. The thing we didn't mess with was the legendary performance — making the CL the same workhorse you can rely on, day after decade.

To get your hands on this upgraded Classic, visit GUZZLER.COM, or call us at 800.627.3171 ext. 298.

GUZZLER
THE TOUGH YOU TRUST.™



Made to Order

CURED-IN-PLACE LINING SOLVES A RESTAURANT'S BACKUP PROBLEMS OVERNIGHT WHILE PROTECTING A HISTORIC VICTORIAN MANSION

BY SCOTTIE DAYTON

The mechanical contractor for Forepaugh's Restaurant hired a plumber to clean the drains, but the attempts only enabled the restaurant to limp along until the next episode. The contractor then called Grant Utilities, a local water and sewer utility contractor specializing in cured-in-place pipe rehabilitations.

Grant Utilities' owner Grant Engen used a MyTana camera system to inspect the 4-inch cast iron lateral from a kitchen cleanout. At 11 feet, the camera revealed the problem. "The joint had failed where the lateral connected to the 6-inch clay tile sewer," he says. "Wastewater hitting the debris backed straight into the kitchen."

Although 12 feet of rocky soil separated the joint from the enormous heating, ventilation, and air conditioning units above it, Engen speculated that vibrations from the machinery sifted material into the opening. The only feasible, economical solution was lining the lateral.

"We measured the distance to the joint three times with the camera," says Engen. "The short distance made calculations easier, but accuracy was still key. If we messed up, we were out of options, as there was no way to open-cut the line."

Working mostly at night in sub-zero temperatures and wind chills, Engen and three technicians repaired the joint with a transition liner from Perma-Liner Industries, enabling patrons to again enjoy refined culinary dining experiences.

Brandon Hedlund of Grant Utilities makes a dry run with the inversion unit to guarantee that the delivery hose lines up with the host pipe. (Photos courtesy of Grant Utilities)

tough job

PROJECT: Rehabilitate clogged lateral in restaurant kitchen

CUSTOMER: Forepaugh's Restaurant, St. Paul, Minn.

CONTRACTOR: Grant Utilities, St. Paul

EQUIPMENT: Transition Liner, Perma-Liner Industries, LLC, 866/366-2568; www.perma-liner.com

RESULTS: Flow restored, restaurant reopened

PREPARING THE WAY

During the week, Forepaugh's opened at 5 p.m. Engen staged his equipment near the restaurant's trash receptacles and HVAC enclosure. "Our plan was to access the lateral as it left the enclosure, then clean upstream," he says.

After breakers on the Case 590 Super M excavator bucket broke through the 42 inches of frozen ground, operator Mike Boston dug an 8- by 10- by 12-foot-deep pit and lowered a metal trench box. The unstable bottom of the pit made it necessary for Boston to suspend the box by chains. Workers then exposed the

(continued)

AMAZING MACHINERY

Your Equipment SUPERSTORE Since 1995



130' SEWER CAMERA with 512HZ SONDE

SYSTEM INCLUDES

- » 7" Flat Screen LCD in ABS Case
- » Records to SD card (NOT INCLUDED)
- » High Quality Color Camera
- » 1-3/8" Diameter Camera Head
- » 512 Hz Sonde Transmitter (8'-15')
- » Stainless Steel Camera Body With Sapphire Lens
- » Water Resistant Camera Head
- » 9 White LED Lights w/Dimmer
- » 12" Steel Spring Leader
- » 130' long, 3/8" Super Slick Push Cable
- » 20" Storage Reel
- » Operates On 120 Volt Electricity
- » Two Year Mfg. Limited Warranty

SALE Price
\$1995.00

**Sewer Camera
Repair Center Now Open**

Add This Locator
to Any Camera!

Only **\$499.00**



Complete Details At
www.AmazingMachinery.com

1-800-504-7435
2160 S Lee Hwy. • Cleveland, TN 37311



In mid-January, historical Forepaugh's Restaurant in St. Paul, Minn., had sewage backing up through the floor drains in the food preparation area.

"With the drains sealed, air vents out the stack instead of making a mess," says Engen. "We tried to minimize the time the staff would have to spend sanitizing the kitchen after we left."

BABY, IT'S COLD OUTSIDE!

Inside the trailer, the team measured and cut the 20-foot-long 3-mil transition liner with 4- and 6-inch lengths sewn together. Because Perma-Liner doesn't have a resin applicable for sub-zero temperatures, Engen chose the closest match: the company's cold weather resin with chemical reaction beginning at 137 degrees F.

"Cold weather stresses everything," says Engen. "When resins are shocked by the introduction of minus 2 degree air, it takes time for the chemicals to recover. Our biggest concern, however, was condensation developing in the air compressor, then freezing in the hoses."

Before wetting out the liner, they started the compressor, blew it out, and kept it running to prevent moisture buildup. "That way, when we hook the hoses to the inversion unit, we're getting a full flow of air," says Engen.

After wetting out the liner and lubricating it with vegetable oil, the crew rolled it inside the inversion machine. "We work inside the trailer as long as possible to keep everything warm," says Engen. "I wasn't worried about shortening working time because it was so cold outside."

After stationing the air hoses by the hole, the crew rolled the inversion unit down the trailer ramp and wrestled it to the pit. Because of its depth, Hedlund tilted the unit downward, enabling Boston to line up the hose and pipe in the hole. They inverted the liner at 9 psi, stopping 6 inches short of the cleanouts.

Despite the cold, the yellow calibration tube rolled easily into the inverter, then inflated at 10 psi. The pressure was maintained while the resins cured. "Everything done outdoors in winter takes twice as much time as in summer, because the guys are wearing bulky clothes and can't move as fast," says Engen. "They also were unaccustomed to working off hours and at night."

"Cold weather stresses everything. When resins are shocked by the introduction of minus 2 degree air, it takes time for the chemicals to recover. Our biggest concern, however, was condensate developing in the air compressor, then freezing in the hoses."

Grant Engen

line and Brandon Hedlund made a dry run with the inversion unit to guarantee that the delivery hose lined up with the host pipe.

"We couldn't jet the line until after the restaurant staff finished cleaning up for the night," says Engen. The crew returned at 11 p.m. with a portable MyTana jetter delivering 3,200 psi/12 gpm and a 32-foot heated trailer with Perma-Liner equipment. "We custom-built the trailer because we needed more room to work," says Engen.

To illuminate the area, they used the lights on the excavator, mounted a light to the arm so it shined into the trench box, and lowered a trouble light into the hole. A generator mounted next to the trailer supplied power.

Upon opening the lateral, Hedlund found the pipe in good shape after its two recent cleanings. He touched it up using a standard jetting nozzle. Meanwhile, Stan Odger covered the kitchen floor with tarps to protect it from the snow and dirt on their boots, while Engen taped down the floor and sink drains to prevent the traps from spitting water when air was introduced into the pipe.



Stan Odger (background) assists Brandon Hedlund as they prepare the calibration tube for the inversion unit.

www.JETTERSNorthwest.com

JETTERS
www.jettersnorthwest.com
NORTHWEST



BIG-BRUTE
High Flow Jetter

9.0 gpm
4000 psi

- Portable 4-Wheel Cart or Mountable Skid
- Includes 300' of Hose and 4 Jetting-Nozzles
- Gasoline or Propane fueled OHV-engines

JETTERS: CARTS • TRAILERS • MOUNTABLE SKIDS

Toughest Jetters Available... Call: **1-877-901-1936**
Expert Advice and Service email: info@jettersnorthwest.com



THE
LEADER
SINCE 1923



THE BEST, MOST RELIABLE & COMPLETE LINE
OF HOSE, CORD & CABLE REELS

www.COXREELS.com
800.269.7335 • info@coxreels.com

HGACBuy.com
THE SMART PURCHASING SOLUTION



800.767.1974 rstechserv.com

the CUBE

conductor
THE SINGLE SOLUTION

The power of a full mainline system in a free-standing, mobile solution

- Mainline system with up to 1,500' of cable
- Rack mount or laptop data collection system
- Fully self-contained with on-board generator, two 500 lb capacity storage drawers and front access 9-gallon pressurized wash-down system
- Fits on an ATV or in the bed of a pickup truck

For more information about this inspection tool and our full range of inspection equipment solutions, call or visit us online today.



RS Technical Services Inc.
Design and Manufacture of Video Pipeline Inspection Systems

BETTER SAFE THAN SORRY

Over the seven hours the liner remained inflated, the team took turns going into the pit to monitor the gauges and make sure everything was holding pressure. "Although the liner can feel firm where it is exposed, I don't know what's happening with the rest of it," says Engen. "I erred on the side of caution and always cure liners longer than the manufacturer's recommended time."

In the morning, they removed the calibration tube and connected the liner to the sewer with a length of PVC pipe and Femco rubber couplings. To fulfill the city's requirement for a post-inspection DVD, Hedlund inspected the liner from the kitchen where the cold could not affect the electronics. "It was a good effort," says Engen. "We got them up and running without any further issues." c

TRYTEK
MACHINE WORKS, INC.

6" to 15" Tap Cutter

FAST DELIVERY
on
replacement parts



We accept most
major credit cards

**Hundreds
in use!**



www.trytek.com

Contact us for more information:
Phone: 717-428-1477
Fax: 717-428-2865
Email: trytek@trytek.com
250 N. Main St.
Jacobus, PA 17407 USA

Serving the
industry for over
25 years

COAST MANUFACTURING

Professional-Grade Drain Cleaning Machines, Cables & Accessories



Drain Cleaning Machines

- ▶ Heavy duty construction
- ▶ The most powerful motor in the industry
- ▶ Quick and easy reel changeover
- ▶ A one year rock-solid warranty



Cables

- ▶ Fabricated from high quality wire
- ▶ Most ends & couplings available
- ▶ All sizes and lengths
- ▶ Innercore available

COAST MANUFACTURING

www.coastmanufacturing.com
1.800.541.7015

LAPLACE EQUIPMENT

RENTALS, SALES & SERVICE

• WATERBLASTERS:

- PRESSURE TO 40K, FLOW TO 100 GPM
- WATER JETTING TOOLS
- HYDRO-MOWERS
- 3D NOZZLES
- ROTATING NOZZLES
- HIGH PRESSURE HOSES
- LANCES
- FITTINGS
- TIPS
- SUPPLIES
- EXPERIENCED TEAM FOR PLANNING, TRAINING & SETUP

CALL
985.652.5210
FOR YOUR
WATERBLAST
PROJECT
SOLUTIONS
WWW.H2OBLAST.COM

Get Plugged In

AFTERMARKET CONNECTORS • CABLES



Reinforced • Tougher Cables/Connectors • Poly U • Fiber Optic
 Shipments Can Be Sent To Crew's Motels

REASONABLE PRICES

Seacon/
 Turck



OceanQuip LLC
 ORCA TOUGH CABLES

504 738 7833 p/f • jfowler307@aol.com
www.OceanquipLLC.com

Meeting a CHALLENGE?

Do you have a Tough Job story to tell?

Drop us a line at editor@cleaner.com and tell us about how you met a serious jobsite challenge to delight a customer.

Cleaner

YOU ARE INVITED to September 11th-12th, Rochester, Indiana

Free Training, Food and Fun!
**September
fest 2013**

HD PEGASUS® HANDS-ON DEMONSTRATIONS
BOTH DAYS OF EVENT!

High-Definition Inspection Systems

You probably have a high-definition TV at home. Truth is, your mobile phone probably has a higher resolution than your current CCTV inspection system. The time has come to bring dramatically higher visual fidelity to the sewer inspection market. If you are a Municipality interested in working with the best video data available or a contractor wishing to leverage the quality of your services - The PEGASUS® HD system is for you!



Watch a Video Sample
of PEGASUS® at:

www.rapidview.com/hd

Flexi Gator
4" - 8"

Mini Gator 8" - 24" **Alli Gator** Over 10"



Single Entry - Multiple Jobs

Introducing the most advanced line of cutting and grinding robots on the market today! The GATOR® Series by IBAK provides operators with the quiet, clean power needed to accomplish the toughest jobs. The revolution of electrical cutter/grinders means that you can do your entire line from one access point without noisy air compressors or messy hydraulics.



**EXPERIENCE the Power,
Safety, Reliability and
Cost Savings of ELECTRICITY!**

FREE TECHNICAL TRAINING HANDS-ON TRAINING
BOTH DAYS OF EVENT!

FOOD & ENTERTAINMENT



REGISTER FREE at:
www.rapidview.com



(800)-656-4225

Saving For a Rainy Day

AMPLE LIQUID CASH RESERVES HELP YOU WEATHER INEVITABLE FISCAL STORMS AND EMERGE WITH YOUR PROFITABILITY AND LONG-TERM BUSINESS PLAN IN TACT

BY ERIK GUNN



Erik Gunn is a business writer in Racine, Wis. Readers may direct inquiries to him by contacting this publication at 800/257-7222 or emailing editor@cleaner.com.

“Save for a rainy day!” How many of us heard that advice as kids when we got that first bank account or perhaps learned elementary financial management in school? Now that we’re adults, we may appreciate the advice even more – and even better, follow it.

It’s advice that’s just as important for a business as for an individual or household. And for a small business entrepreneur, it can be especially hard to follow – as financial advisor Alan Moore knows well.

“We tend to be risk takers,” says Moore, who operates Serenity Financial Consulting LLC with offices in Milwaukee, Wis. “Many of us had to put absolutely everything we own into a single pot to start the business.” As the business grows and revenues build, there’s a temptation to use it to buy new

“We tend to be risk takers. Many of us had to put absolutely everything we own into a single pot to start the business ... As a risk taker it can be so hard to just see cash sitting in an account and not doing anything.”

Alan Moore

equipment, expand the business, or even just invest it in something with a high yield: “As a risk taker it can be so hard to just see cash sitting in an account and not doing anything.”

However difficult it may be, putting away cash is critical to the long-term survival of your business. No matter how well you’re doing now, a business downturn is inevitable. Whether you survive can depend on how substantial your rainy day fund turns out to be. That will be when you find out for yourself what Moore says: “The cash reserve is the single most important investment that a business can make.”

HOW MUCH?

For an individual or household, the standard rainy-day-fund advice is to save three to six months’ salary to tide you over to cover bills and expenses if you lose your job. For business, that might be a starting point, but the principles are more complex. “It’s more about, what will it take to survive?” Moore points out. Ask yourself:

How steady is your monthly cash flow? Does it go up and down sharply, perhaps because of seasonal factors that influence the demands for your business? Or are you pulling in roughly the same amount of revenue each month? The more volatile your cash flow, the larger reserves you are likely to need.

What is the nature of your expenses, and are there easy ways to cut back if money gets tight? Are your personal reserves strong enough that you don’t need to keep paying your own salary? Will you try to find a new complementary line of business for which you’ll need to spend money marketing and buying equipment?

How large and diverse is your client base? “The larger and more diverse the income streams and client base, the less risk you potentially have in bad times,” Moore says. If a large part of your income comes from one client that suddenly closes or switches to a competitor, your revenues and profits will take a big hit.

The same is true if you have several clients, but they’re all in a niche vulnerable to common disaster. Imagine the plight of a septic pumper in a resort region who has all the contracts to pump out systems for area campgrounds – and then a massive forest fire closes the camps for months until they can make repairs.

If you have a wide variety of customers and no single one represents a big chunk of your business, you may be able to get by with smaller reserves.

And what about your supplier base? If you count on one equipment or consumables supplier who suddenly goes out of business, your company might suffer, too, until you find a new vendor, or even if you just have to pay a higher price to buy from someone else.

Where do you get it? The answer will be different for everyone. If you collect deposits from customers before starting work, Moore suggests funneling that check straight to your rainy day fund. That might not be possible for everyone. Many small contractors put deposits to work buying materials for the job itself. And some might not collect a deposit at all.

In that case, Moore advises putting a fixed percentage of each dollar in revenue – say 5 or 10 percent – into your reserve fund.

Perhaps a sudden windfall, or at least part of it, could be diverted to your rainy day fund as well.

How do you keep it? An effective rainy day fund has three critical features: It’s liquid – easy to get at without fees or penalties. It’s safe – not at risk of losing value because of market fluctuations. And it’s out of sight.

For liquidity, nothing beats a savings or checking account. You don’t even want to put it in CDs, although they earn a little more, because if you have to cash out early, the penalty will wipe out your return.

Shop around for the best interest rate you can find, using a service such

Mid-Atlantic Waste Systems

Stock Equipment Priced to Sell! **800.338.7274** EXT. 1009



- | | | | | | |
|--|--|--|--|--|---|
| <p>Combination Sewer Cleaner Vacall AJV 1215</p> <ul style="list-style-type: none"> • 2012 Freightliner M2 • 410 HP Diesel Engine • 85GPM @ 2000PSI Myers • Roots 18" PD Blower | <p>Combination Sewer Cleaner Vacall AJV 1015</p> <ul style="list-style-type: none"> • 2008 Sterling • 350 HP Cummins Diesel Engine • 80GPM @ 2000PSI GE • Roots 16" PD Blower | <p>John Bean Sprayers Sewer Jet JB7040D</p> <ul style="list-style-type: none"> • 40 GPM at 2000 PSI • 80 HP John Deere Diesel • KEG Nozzle Upgrade Pkg. • Only 10 Hours | <p>Rausch M-Series Camera Trailer</p> <ul style="list-style-type: none"> • Side Office with Posm Software • Mainline & Lateral Launch • 100' Lateral Inspections • 1250' Main Cable, 6-60" Daimeter | <p>TV Perrett Portable Camera System</p> <ul style="list-style-type: none"> • Mainline Camera Pan & Tilt • Screen Footage Counter • DVR Recording • 600' Mainline Cable | <p>Hathorn OPT HDD 12.1 Push System</p> <ul style="list-style-type: none"> • 12.1" HDMI LCD Screen • 320GB HD with USB Ports • Play, Pause, 8X Digital Zoom • 200' Cable w/Self Level Camera |
|--|--|--|--|--|---|

as bankrate.com to help you make comparisons. A money market bank account may give you a higher rate of interest. Use that, but only if you can be sure you won't have to suddenly go below the minimum balance, which not only stops paying interest but may start incurring fees.

Moore understands the temptation to put at least some reserves into a higher-yielding investment, such as a mutual fund, even one balanced between stocks and bonds. His advice: Don't do it!

"Your reserves are insurance against bad markets," he notes. And what happens in bad markets? Investments often go down. Suddenly that reserve fund you've put into an investment portfolio so you can get a 3 percent return instead of the 1 percent the bank offers is down 10 percent, 20 percent or more – wiping out whatever you might have gained and more.

As for "out of sight," at the very least the reserves should be in a completely different savings account from the accounts you routinely use to pay bills and receive revenue. But Moore often suggests clients go a step further, and put the reserve in a completely different bank.

Although you want it liquid, "you don't want it super-accessible," he explains. "If you stare at it every day when you log in to look at your checking account, you're going to see that money just sitting there and it will bother you."

PEACE OF MIND

When the worst happens and business suddenly goes south, it's critical to be thinking about what really matters. And that shouldn't be how you're going to get through the month. "You need to focus on correcting the underlying issue, not paying your bills," Moore says. "If your main focus is how to make payments, you're going to be focused on the wrong thing."

Suddenly, when a new customer calls, you'll feel desperate to make a sale. Perhaps you'll ignore red flags that would tell you to turn the business down. Or you'll undercut yourself in your bid just to get the business. But if you have healthy reserves when you need to crack open that piggy bank, you can take a deep breath and really think long-term. And that will be the best way to bring your business back. **e**

MUNICIPAL SEWER AND WATER
FOR SANITARY, STORM AND WATER SYSTEM MAINTENANCE PROFESSIONALS
MSWMAG.COM

Petersen® Pipe Plugging Systems



Pipe Plugs and Packers for all your Pressure, Chemical, and Temperature Requirements. Call us to quickly customize a pipe plug or plugging system for your specific application.

Economical Hot Tap Plugging Systems

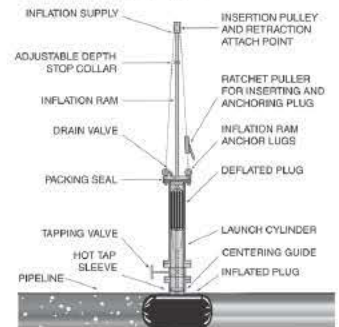

www.pipeplug.com

Petersen PRODUCTS COMPANY
Serving Professionals Since 1916

PHONE 800.926.1926 OR 262.692.2416
FAX 800.669.1434 OR 262.692.2418

Meeting Our Customers Highest Expectations

JD Jetter Depot

NOZZLES • HOSES • PARTS • ACCESSORIES

Visit our 'NEW' website www.jetterdepot.com

FAIR PRICES • QUALITY SERVICE • GUARANTEED

678 431 8136 • www.jetterdepot.com

This Is The Nozzle You've Been Waiting For

Root Rat *root cutter nozzle*

MADE IN THE USA

1/2" 3/8" 3/4-1"



7-35 gpm/1500-10,000 psi

3-10 gpm/2000-7500 psi

40-160 gpm/1500-4000 psi

Custom Built Jetters

Root Rat Combo Kit



"The Root Rat is the easiest and most versatile root cutter nozzle I have ever used. The Root Rat works where other nozzles fail."
Tim Jones, owner of Eastern Sewer Jetting



Hot or cold water jetters from 4 gpm at 4000 psi to 12 gpm at 4000 psi, skid or cart frames or small trailer systems.

3/4" - 1" root rat combo kit. Use a reducer adapter to go from 1" to 3/4".

WE SELL AND SERVICE COLD WATER JETTERS
We sell parts, pumps, unloaders, hoses, jet tips, etc.

CHEMPURE PRODUCTS CORP.
1-800-288-7873 • 330.874.4300

Visa, Mastercard, Discover, AmEx Accepted

www.chempure.com



Need a better way to exchange information?

MuniXS™ software gives you the power to quickly capture and share pipe survey data in PACP format.

Easily burn surveys to CD or DVD within MuniXS. The flexiplayer export requires no installation to view movies, pictures and reports.

Improve your data exchange—call today for an online demo and more information.



MUNIXS PACP SURVEY SOFTWARE

866.299.3150
www.munixs.com

another innovation from PIPELOGIX
Innovative Solutions for Infrastructure Management



THE PLACE TO BUILD YOUR BUSINESS.

FEBRUARY 24 – 27, 2014 • INDIANA CONVENTION CENTER • INDIANAPOLIS, IN

WWW.PUMPERSHOW.COM

866-933-2653

Allan J. Coleman – Since 1905

Call us today! 773-728-2400

5725 North Ravenswood Avenue • Chicago, IL 60660 • info@allanjcoleman.com

Authorized SeeSnake Repair Center

**THE BEST
SERVICE AND
FAST TURN
AROUND!**

**OLDEST NAME IN THE BUSINESS
— Over 100 YEARS OLD —**



NaviTrack® Scout®

Scout is designed to solve demanding remote transmitter (sonde) locates using multi-directional locating technology.

SeekTech® SR-20

SeekTech uses omni-directional antennas, guidance arrows and an easy to read mapping display.



RIDGID®

CS10 Digital Recording Monitor

- USB Thumb Drive Recording
- 12.1" Daylight Readable Display
- Multi-Mode Recording
- Software Integrations



**Convert
your old RIDGID
VCR monitor
to a USB
recorder!**



**Contact
us on
how we
can do it?**

SeeSnake® MAX rM200 Camera System

- Next Generation Push Cable and Improved Reel Mechanics
- Ultra Compact Camera Head
- Transport Enhancements
- Docking System
- Self-Leveling Camera Head



We Have RIDGID Parts!

If you buy the best, you are only sorry once!

Waterblasting and Waterjet Cleaning and Accessories

BY CRAIG MANDLI

Waterblasters and portable jetting systems are essential tools in a professional drain and pipe cleaning business. The right equipment can help you build profit. Check out the selection of products below to find the right waterblaster, jetter, cleaning nozzle, vacuum truck or truck accessory to help do your job safely, efficiently and effectively.



WATERBLASTERS

1. HIGH-PRESSURE WATERBLASTER

The Aqua Miser Ultra Boss Model E75V-II with closed-loop containment system from CESCO removes rust and paint by using water pressures up to 40,000 psi without releasing chemicals into the air. The system captures the water, filters the paint particles for disposal, and reuses the water for further paint removal, keeping harmful particles out of the air. The system reduces emissions and hazardous waste, as well as man-hours. 843/760-3000; www.aquamiser.com.

2. COMPACT WATERBLASTING SYSTEM

The IX100 Series compact waterblasting system from Jetstream of Houston features a UNx fluid system designed for fast conversion between 8,000 and 40,000 psi operating pressures. Additional features include an external gear drive, comprehensive shutdown systems, a high-performance 93 kW Tier 3 engine, high-capacity fuel tank and sealed control panel. Options include an air compressor, extended-run fuel tank, inlet regulator, insulated exhaust system, bench vise, remote e-stop, lube water recirculation pump and system pressure sensor and over-pressure shutdown. Shutdown systems include low-supply water pressure, dirty water filter, engine fault, manual emergency stop and manual override. The heavy-duty compact frame is hot-dip galvanized. 800/231-8192; www.waterblast.com.

JETTERS

3. HIGH-FLOW CART JETTER

High-flow cart jetters from American Jetter utilize a 12-gallon water tank that works much like an air compressor tank, allowing a buffer zone for the pump water source. The balance of the system allows the user to move the cart with the tank empty like any ordinary cart jetter. Once in position, connect a garden hose and start to jet. Oversize supports provide enhanced operation stability. Each unit comes standard with portable hose reel with up to 300 feet of 3/8-inch hose, foot valve operation for safety, wash down gun kit and a set of three jetting nozzles. Options include wireless remote, Wart Hog nozzle, and several flow/psi rates. 866/944-3569; www.americanjetter.com.

4. HIGH-PRESSURE GAS WATER JETTER

The Eel Jet EJ3000 gas jetter from Electric Eel cleans 2- to 8-inch-diameter lines up to 300 feet. It features steel nozzles that penetrate and clean sludge, ice, grease, sand, soap, dirt and debris from pipe walls with a variety of spray angles in septic systems, factories, hospitals, hotels, shopping malls, restaurants and other applications that need wall-to-wall drain cleaning. It has pressures of 3,000 psi and 4.7 gpm, with a 13 hp overhead valve engine (with electric start available), a 2-to-1 gear-reduced triplex pump with pulsation, a 300-foot-capacity hose reel, a throttle back control that automatically adjusts engine speed, a low-tone muffler, 12-inch pneumatic tires on a rugged steel base with front bar for motor protection, heat shield to protect the hose, and



nozzle storage on the unit. It utilizes 1/4- and 3/8-inch-diameter jet hose. 800/833-1212; www.electriceel.com.

5. TRAILER JETTER

The JM-2512 Typhoon trailer jetter from General Pipe Cleaners delivers 12 gpm at 2,500 psi. A 200-gallon holding tank carries enough water to handle remote applications where access to water is limited. It features electric brakes, safety strobe light, safety cones, rear fold-down stabilizer jacks, retractable hose guide arm, and antifreeze system as standard equipment. Its 24 hp Honda engine with electric start and 10-gallon fuel tank ensure extended performance on stubborn stoppages. On-demand Vibra-pulse helps slide the nozzle around tight bends and propel the hose down long lines. Two hose reels — a jet hose reel with 400-foot by 1/2-inch capacity featuring variable speed electric rewind, and a water supply hose reel carrying 150 foot by 3/4-inch hose — are mounted at the rear of the unit next to the pressure gauge and output valve. 800/245-6200; www.drainbrain.com.

6. DIESEL-POWERED HYDROJETTER

The O'Brien 7040-SC diesel-powered hydrojetter from Hi-Vac features plate-mounted polyethylene water tanks that have a 700-gallon capacity. The swinger reel pivots 190 degrees, providing easy access to the manhole regardless of how the trailer is parked. The hydraulically actuated reel has a variable-speed control. It is powered by a 65 hp Cummins diesel with Murphy safety gauges and variable electronic throttle control. The triplex pump is rated to 40 gpm at 2,000 psi. The standard 400-foot high-impact thermoplastic sewer hose is easy to clean, maintains stiffness and is abrasion-resistant. The tandem-axle trailer has a 6-foot channel frame and is rated to carry a full tank of water at highway speeds. 800/638-1901; www.obrienmfg.com.

7. ELECTRIC DIRECT-DRIVE PRESSURE WASHER

The Steam Jenny electric cold pressure washer from Jenny Products can be used in enclosed areas where gas-powered machines can't be used. It is powered by a Marathon or Baldor electric motor, depending on the model, and ranges from 1.5 to 10 hp. It is available with either single-phase GFCI or

three-phase power requirements. It has industrial-grade triplex ceramic plunger pumps, pressure ratings between 1,000 and 4,000 psi, and flow rates between 1.5 and 4.8 gpm. Features include a seven-gauge steel chassis, heavy-duty unloader valve, safety relief valve, thermal relief valve, and high-capacity inlet in-line water strainer. It also comes with an insulated trigger gun, a 50-foot hose with quick coupling, and a series of 0- to 40-degree-angle color-coded nozzles. 814/445-3400; www.steamjenny.com.

8. PORTABLE JETTER

The MV80 Jet Pro Cart from MyTana Mfg. Company delivers 8 gpm at 3,000 psi, and is powered by a 24 hp Honda engine. It includes a 12-gallon water tank that is set up for continuous resupply from the garden hose, 250 feet of 3/8-inch thermoplastic jetter hose and a set of nozzles for penetrating, cornering and blind thrust. Also included is a hose cart with two reels — one for the 3/8-inch hose and one for a 50-foot jumper hose, which is useful for remote jetting. 800/328-8170; www.mytana.com.

9. PORTABLE SWAGE MACHINES

The Brutus and Lil' Brute portable swage machines from Piranha Hose Products make repairing a sewer cleaning hose easy in any environment. Each machine even has a drawer to hold dies for repairs. Brutus repairs hoses from 5/8 to 1 1/4 inch, and Lil' Brute repairs hoses from 1/4 to 1/2 inch. 800/250-5132; www.piranhahose.com.

10. HYBRID HYDROJETTER

The Model 740 hybrid hydrojetter from Spartan Tool features a full 4,000 psi of jetting power at a 12 gpm flow on a wide-track towable chassis. It is available in either a traditional gasoline-powered configuration or in a hybrid that runs exclusively on liquid propane. Cleaner and cheaper to operate, the LP version allows full jetting power wherever it's needed, even inside food processing plants and other air quality-conscious locales. The unit features 350 feet of hose and a 40 hp electric-start engine. It is also available in a skid-mounted version for installation onto an existing van or trailer. 800/435-3866; www.spartantool.com.



11. COMPACT VACUUM SYSTEM

The Fury 2400 Series compact vacuum system from Steel Eagle provides a one-step unit that pressure washes, rinses and instantly recovers the waste stream for proper treatment. Features include electric start, a high-efficiency vacuum pump, vacuum gauge, high vacuum engine shutdown, automatic wastewater pump-out, heavy-duty frame and waste tank, waste collection bag filter, hour meter, 50-foot vacuum hose and a one-year warranty. It has a maximum airflow of 235 cfm. 800/447-3924; www.steeleagle.com.

12. AUTOMATED TUBE LANCING SYSTEM

The StoneAge Sabertooth automated tube lancing system is remotely operated, offering better visibility and increased safety by moving the operator away from the hoses. The self-contained dual hose reel has up to 52 feet of usable stroke for cleaning tubes from 0.87- to 2-inch diameter at up to 22,000 psi. The autostroke feature recognizes when a nozzle has reached a blockage and automatically retracts the hose slightly to keep the tool rotating. Remote shotgunning capabilities are also available, allowing for safe cleaning of exterior bundle faces and tube interiors in one setup. The entire assembly is quickly dismantled to fit through 24-inch manways. 866/795-1586; www.stoneagetools.com.

NOZZLES

13. ECONOMY NOZZLE KIT

The Economy Jetter Nozzle Kit from Amazing Machinery includes a laser nozzle, ram nozzle and rotating nozzle. The laser nozzle, which includes a forward and three back jets, dislodges blockages. The ram nozzle (three back jets) flushes loose debris so that maintaining a fluid motion without irritation is possible. The rotating nozzle (two side and two back jets) polishes and maximizes line recovery. Each nozzle comes in two separate sizes. 800/504-7435; www.amazingmachinery.com.

14. TOWABLE JETTER NOZZLE

The Cnt-r-KUT "TOW HOOK" towable jetter nozzle from Arthur

Products allows for pressurized water to be applied by the integration of a towing nozzle which can be pulled through the line. The technician can also pull a line from point "A" to point "B" if required. It is flexible enough to conform to damaged or deformed lines and can easily be trimmed in the field to fit virtually any line from 2 to 8 inches in diameter by attaching a 3/8- or 1/2-inch National Pipe Taper hose to one end. It is available in a standard and mini size. 800/322-0510; www.arthurproducts.com.

15. LOW-MAINTENANCE CUTTING NOZZLES

Root Rat cutting nozzles from Chempure Products are used with jetters from 11 hp to large truck-mounted models. Manufactured of hardened stainless steel, the cutters come with a toolbox with two interchangeable rotors — one with cables and the other with chains. The combination kit includes extra chain, cable and bearings. They need no repair or rebuilding other than bearing replacement, which can be completed in under two minutes for less than \$10 in parts. 800/288-7873; www.chempure.com.

16. ROTATING DRILL NOZZLE

The Rotodrill nozzle from Enz USA features a rotating front jet for improved cutting performance. It is ideal for clearing blocked and frozen pipes, and moving heavy debris. It has excellent propulsion, but can also be used in hydroexcavation by plugging off the thrust jets. This versatile nozzle is available in 1/2-, 3/4- and 1-inch systems. 877/369-8721; www.enzusainc.com.

17. SPINNING SEWER NOZZLE

Spinning sewer nozzles from NozzTeq are available in 1/2-, 3/4-, 1- and 1 1/4-inch sizes with two kinds of sleds. They are made of stainless steel and brass, and require no oil, daily maintenance or rebuild kits — just washing off at the end of the day. They include rear-thrusting jets, and not only cut grease, but also can be used to clean the pipe without putting another nozzle in the line. They can clean sewer or stormwater pipes from 2 all the way up to 18 inches. There are two stainless sled types available for the largest spinner. 866/620-5915; www.nozzteq.com.

(continued)

SAME-DAY SHIPPING. PROBLEM SOLVING. MAKING IT HAPPEN.

We're here with whatever you need
when the pressure's on.



Jetstream[®]
There's A Way. 

The waterblasting source for parts, service & expertise. To learn more, visit waterblast.com.

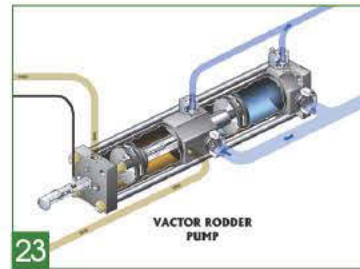

18. ROOT-CUTTING NOZZLE

The RR3000 Root Ranger nozzle from RIDGID uses a single rear-facing turbojet to blast a concentrated stream of water that shears root obstructions from the drain wall. It is capable of clearing lines up to 8 inches, and can completely clear lines larger than the one it originally entered. It comes standard with 200 feet of hose. 800/769-7743; www.ridgid.com.

19. FLEX LANCE

The 3/6 Blast-Pro waterblast flex lance from SPIR STAR features a 0.50-inch end fitting OD and 40,000-psi working pressure. It is available with 1/4-inch 28 and 3/8-inch 24 male nipple ends and can be used in small-diameter tube cleaning applications. 800/890-7827; www.spirstar.com.

20. STAINLESS STEEL CLEANING NOZZLE

One-piece stainless steel cleaning nozzles from USB - Sewer Equipment Corporation are neither bonded nor screwed together, enhancing strength and reducing chances of failure under pressure. Their advanced, optimized 3D Hydro Mechanics, located in the lower part of the chamber, eliminate pressure in the upper portion of the nozzle and prevent explosion. The water coming from a pressurized hose is immediately guided directly into channels and smoothly into a one-piece ceramic nozzle insert, which do not require winglets or flow-straighteners because of the hydromechanics in and out of the chamber. They are ideal to remove sand, mud, silt, grease and obstructions from sewer and stormwater lines. 866/408-2814; www.usbsec.com.

WATER PUMPS

21. PLUNGER PUMP

Plunger pumps from Moro USA are high-pressure triplex water pumps that produce a smooth liquid flow up to a maximum water temperature of 140 degrees on standard pumps (higher temperature ratings available). The double-projection drive shaft can be operated by pulley, flexible joint or cardan shaft. The pump includes ceramic plungers, double-pressure packings, vertical-fitted valves, water spill venting, and oil-bath mechanical

parts with splash lubrication. They are available with a maximum flow rate of 128 gpm and maximum pressure of 22,000 psi. Versions include stainless steel or aluminum-bronze fluid ends. 800/383-6304; www.moroussa.com.

22. HIGH-HEAD PUMP

The portable 6-inch, high-head 6JCC pump from Thompson Pump delivers 1,100 gpm, high heads to 490 feet and 212 psi. It is ideal for high-pressure applications such as water jetting, water boosting, wellpoint installation, water supply for hydraulic fracturing, washdowns, tank cleaning and fire protection. It offers the Enviroprime System that provides ultra-reliable, automatic initial priming and re-priming. Options include the Silent Knight sound-attenuated canopy. 800/767-7310; www.thompsonpump.com.

23. SINGLE-PISTON WATER PUMP

The dual-action, single-piston JetRodder water pump from Vactor Manufacturing features a hydraulic cylinder on one side of a sealed center block and a water cylinder on the other side. A single shaft with specially constructed piston heads is slowly driven back and forth. The pump is constantly loading and expelling hydraulic oil and water. The pump's jackhammer action helps to further break up debris caked on pipe walls and provides additional cleaning power to break through obstructions in the line. A slow stroke design reduces friction, providing longer field life and less maintenance. There are no belts to adjust or maintain and only five moving parts. It comes with an unconditional 30-minute run-dry certification. 800/627-3171; www.vactor.com.

HOSE REELS/FITTINGS

24. HOSE FITTINGS/ADAPTERS

UHP hose adapters, couplers and fittings from All Jetting Technologies are manufactured in male-to-male, female-to-female, and male-to-female configurations. UHP straight and reducer couplings are also available. Hose glands and collars are provided with couplings unless otherwise specified.

(continued)

SCOOTER

VIDEO
INSPECTION SYSTEMS

20843 Santa Lucia • Tehachapi, CA 93561 • Fax: 661.822.8917

"Simplify your life!"

SCOOTERS ARE EASY TO USE, TOUGH AND DEPENDABLE.
DON'T LEAVE THE SHOP WITHOUT ONE.



**Tired Of Squinting
At A Tiny Monitor?**

Get An
Attaché
With A

15" LED
Hi-Def
Monitor

The new Scooter Attaché now includes a giant 15" LED hi definition color monitor as well as a high quality DVD recorder, and has the capacity to operate other camera systems tool



**SPECIAL
PACKAGE**

Scooter 200

Color, Attaché DVD, Locator Transmitter, Voice Over

Complete Package \$4,995

Call for SPECIAL PRICING on
ATTACHÉ II & III

800.772.6165
www.tvinspection.com





Adapters are designed to simply couple standard type “M” fittings to autoclave fittings. All adapters, couplers and fittings are manufactured with 316 stainless steel. 772/286-1218; www.alljetting.com.

25. PRESSURE WASHER HOSE REEL

The **PW-2 Series** hose reel from **Hannay Reels** quickly mounts to almost any type of pressure washer. It is designed for mobile and portable pressure wash equipment, as well as steam cleaning, spray and washdown applications. It features a pressure rating of up to 4,000 psi, an adjustable split bearing brake assembly and a permanent attached direct-crank rewind. It is constructed of 12- and 14-gauge steel and has a black powder coat finish. 877/467-3357; www.hannay.com.

26. MULTI-GUN VALVE

The **MGV24-1200** multi-gun valve from **NLB Corp.** allows two or more high-pressure water jet lances (or other accessories) to be operated from the same 24,000 psi pump unit, and can be rebuilt in the field in just five minutes. It can be used with any dump-style lance, with nozzles of different sizes. The valve flows up to 24 gpm and weighs 33 pounds. Its modular design accommodates additional bodies to supply more lances, and features a quick-change, stainless steel cartridge for quick field repair and a new cam-lock pressure adjuster that locks the pressure without tools. 800/441-5059; www.nlbcorp.com.

27. DUAL-PEDESTAL HOSE REEL

The **DP7000 Series** dual-pedestal hose reel from **Reelcraft Industries** features a two-piece, non-welded, interlocking base that won't vibrate apart, making it ideal for vehicle-mounted applications. An interlocking steel-formed and stamped base design makes the base assembly strong, compact and resistant to vibration. It has successfully passed independent testing to mil-spec standards and is proven to stand up to heavy vibration. It is available with up to 50 feet of I.D. hose. 800/444-3134; www.reelcraft.com.

28. SAFE HOSE REEL

The **NHR-1000** rotary hose reel from **Terydon** guarantees user safety by removing high-pressure water from the operator's hands. It offers full control of rotation speed (up to 1,000 RPM) and feed rate (up to 1 foot per second) without losing cleaning potential from reaction force. With its moderately small frame, it is ideal for catwalks, manways, and hard-to-reach areas. A switch of the SG Series UHP swivel offers a transition from 20,000 to 40,000 psi. Hose can be removed and replaced in a matter of minutes. 330/879-2448; www.terydon.com.

29. PRESSURE WASHER HOSE

Kobrajet I 4,000 psi pressure washer hose from **Water Cannon** is a wire non-marking gray hose ideal for cleaning surfaces that are likely to show hose marks like pool patios, roof tops and indoor surfaces such as kitchen floors and countertops. It features high-tensile steel wire braid components, with free bend restrictors and a free swivel included in the package. It comes in a variety of lengths and works well with industrial and consumer pressure washers. It can endure temperatures from -40 up to 275 degrees F. 800/333-9274; www.watercannon.com.

SAFETY EQUIPMENT

30. MULTI-GAS DETECTOR

The **BW Technologies GasAlertQuattro**, distributed by **Milwaukee Rubber Products**, is a four-gas detector that combines a comprehensive range of features with simple one-button operation. The graphic LCD displays easy-to-identify icons that indicate operational information, such as bump test and calibration status for simplified onsite auditing. IntelliFlash provides continuous visual confirmation of detector operation and compliance. It is fully compatible with the MicroDock II automatic test and calibration system. It has flexible, interchangeable battery options with extended run-times, and extensive data logging and event logging capability. A full function self-test is initiated upon activation and runs continuously during operation. 800/325-3730; www.milwaukeeerubber.com.



31. WATERJET PROTECTIVE CURTAIN AND COVER

Protective curtains and covers from TST Sweden AB can be put together to form a protective wall of desired length. It withstands up to 43,500 psi at a 10-inch distance. Each section is 60 inches by 98 inches. On top there are five straps for easy mounting and on the bottom there are holes for further securing. The sections are easily connected through six strong and easily handled locks. They are available standard in red with warning sign in English, and optionally available in white, black, yellow, light grey, dark grey, blue and green. Each panel weighs 16.5 pounds. www.tst-sweden.com.

INDUSTRIAL VACUUM TRUCKS/ACCESSORIES

32. BOOM ELBOWS

Custom Boom Elbows manufactures both 70- and 90-degree boom elbows for a variety of hydroexcavator manufacturers for municipal sewer work. Both feature a 25.1-inch circumference and 8-inch diameter with flanged ends. They are built with a 1/2-inch wall thickness. 604/835-0199; www.customboomelbowsbc.com.

33. VACUUM TRUCK

The HV55 HydroVax vacuum truck from GapVax is constructed of ASTM A572-Grade 50 steel, has a 12 1/2-cubic-yard debris body and water tank options ranging from 400 to 1,400 gallons. Specs include a positive displacement vacuum pump rated at 5,250 cfm with 28 inches Hg. The tailgate opens fully with a field-adjustable hinge and dual cylinders, and also has four fail-safe, individually adjustable locks that ensure a complete seal. Optional equipment includes a cold-weather recirculation package, sludge pump, auger unloading system, body pressurization system, remote pendants and wireless remotes, a high rail package and stainless steel body. 888/442-7829; www.gapvax.com.

34. LONG-BODY VACUUM LOADER

The Guzzler Classic (CL) industrial vacuum loader from Guzzler Manufacturing features enhanced operator ergonomics and improved air

routing, filtration and maintenance. A longer body provides improved material separation. The standard ladder, catwalk and railing provide the operator with easier and safer access to the top of the truck. An enlarged bag house and cyclone cleanout access doors provide easier access. The transition to the dump tubes has been widened for more effective dumping. The linear wall connection from the cyclone to the bag house has been increased in size, providing a more efficient airflow. The rounded transition from debris body to cyclone allows the future addition of valves to isolate the tank for adding pressure offload systems. 800/627-3171; www.guzzler.com.

35. LARGE-CAPACITY VACUUM LOADER

The Supersucker HDX industrial vacuum loader from Super Products is equipped with a water system that includes a 600-gallon-capacity water tank setup and hydraulic pump that delivers flow up to 14 gpm and pressure up to 3,000 psi. Its 8-foot articulating boom offers 330-degree rotation and a 27-foot reach, and has the ability to pivot 45 degrees upward and 25 degrees downward. Boom functions can be operated with either a standard wireless remote control or wired pendant. An 8-inch positive displacement vacuum system provides airflow to 5,800 cfm and 28 inches of vacuum. Single-mode filtration enables loading of both wet and dry material with no changeover. A heavy-duty, telescoping double-acting cylinder provides a 51-degree dump angle for thorough unloading. 800/837-9711; www.superproductsllc.com.

36. VACUUM LOADER WITH FILTRATION SYSTEM

The Industrial Vacuum Loader from Vac-Con was designed with a filtration system to handle lightweight dry material, and features superior airflow efficiency. Single-mode machines can recover wet or dry material with up to 28 inches Hg. These positive displacement blowers are capable of pulling material long distances, as much as 700 feet or more. It is available with a hydroexcavation package, which adds a powerful, high-pressure water system that works together with the vacuum system to excavate around sensitive underground utilities, locate underground systems, and excavate in areas with limited access. 904/493-4969; www.vac-con.com.

(continued)



HOME OF THE DOMINATOR® CUTTER



Dominator® Cutters

- » Generation II Infinite Controls
- » Streamlined Air Motors Ranging from .7 HP- 2.5 HP
- » Air & Drive Motor Rebuilds
- » Classic 615 & Jumbo 1236 Repair Parts & Service
- » Free Training at Our Facility on Our Products

BTCS MAGNUM DRIVE MOTORS

For Dominator® 4-30 Cutters



Patent Pending

Designed for Superior Life & Performance.

LEADERS IN CUTTING TECHNOLOGY

717-432-1403 • www.bowmantool.com • bowmantoolco@earthlink.net



37

37. POSITIVE DISPLACEMENT COMBINATION CLEANER

AllJetVac P Series combination sewer cleaners from Vacall use a positive displacement blower system to create the jetting and vacuum forces to efficiently open and maintain critical sewer lines. The blower system is powered by the chassis engine, which reduces fuel consumption, slashes service time and eliminates emissions. The AllSmartFlow CAN bus control system allows the operator to precisely control vacuum forces as well as water flow, using only the proper quantity of water, reducing unnecessary refill trips. Debris tanks have 6-, 8-, 10- or 12-cubic-yard capacities, while 1,000-, 1,200- and 1,500-gallon water tanks are available. They have a front-mounted, pivoting hose reel and an 8-foot, 6-inch extending boom with 180-degree rotation. 330/339-2211; www.vacallindustries.com. c

WWW.CLEANER.COM

KEN-WAY Beats the Others DAY-IN • DAY-OUT

And they have for over 50 years

KEN-WAY CABLE CLEANERS

for cleaning sewer, drain or process lines from one to ten inches, up to 75 feet with the Junior and up to a full length of 300 feet with the Model 400



Junior

Model 400

KEN-WAY Exclusive Built Cables



- Heat Treated
- Inner-Core or Non-Core
- Fit Most Other Brands
- Interchangeable with Most Brands
- Coupling or Blade Holding Types



Leasing plans available. Call for details.
1-800-533-0551

930 ROBERTS ROAD, SPARTA, WI 54656
www.ken-way.com • E-mail: info@ken-way.com

Irrigation fittings are for irrigating – NOT vacuum. How many dollars are you spending **SUCKING AIR?**

Industry-proven, quality vacuum couplings from Bandlock will put money into your pockets.



4" to 12" Male Coupler

4" to 12" Female Coupler

Steel Crown 4", 6" and 8" Press End

Hazardous Material Profile Gaskets (Safety)

Rubber Gaskets

6" and 8" Aluminum Weldon

Aluminum & Steel Pipe

Recognized as the **#1 Relief Valve in the World**

Close Tolerance Couplers And Fittings Bring "Safety" To Your Work Place.

4" and 6" High Abrasive Bulk Nozzles

Special "Y" Reducers

BANDLOCK

EZ Lift Clamps

Standard & International 4" to 12"

Wet Valve, 6", 360° Injected

Male and Female 4" to 12" End Plugs



BANDLOCK
AMESBURY GROUP

MADE IN THE U.S.A.

BANDLOCK Reducers

Download Catalog From Our Web Site!
www.bandlockcouplers.com

1-800-659-2978
Superior "Quick" Connect Vacuum And Pressure Couplings And Accessories

WATERJET PROTECTION

PROTECTIVE CLOTHING - WITH THE STRONGEST FIBER IN THE WORLD!



+ PROTECTION UP TO 43500 PSI

+ CE CERTIFIED
VERIFIED PROTECTION

+ FAST AND EASY GEAR UP
TO MAXIMIZE PRODUCTIVITY!

+ RESISTS WATER AND DIRT
KEEPS OPERATORS
DRY AND LIGHT!

PROTECTION LEVEL 10/28
SINGLE 1000 bar/15000 psi
ROTOR 2800 bar/40000 psi
CE 89/686/EEC

PROTECTION LEVEL 20/30
SINGLE 2000 bar/30000 psi
ROTOR 3000 bar/43500 psi
CE 89/686/EEC



UNIQUE PROTECTION EQUIPMENT

For US distributors and e-catalogues, please visit:

WWW.TST-SWEDEN.COM

Pulsar 2000 Line Tracer

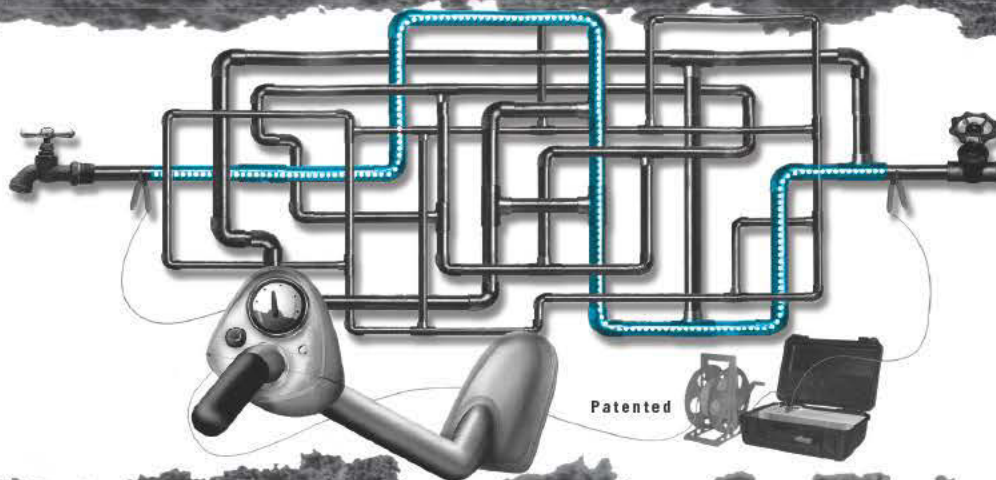

Locate Lines
Locate Water Leaks
Training Video

It's a jumble out there.

www.Pulsar2000.com
DISTRIBUTORS WANTED



The Pulsar 2000 line tracer is designed primarily to locate metallic pipes. The Pulsar 2000 is a directional line tracer. Connect the Pulsar's powerful and unique transmitter to your target pipe and locate only that pipe. Locating can be accomplished under floors, in walls and in ceilings. The Pulsar 2000 does not require grounding.

Leak detection personnel... The Pulsar 2000 is a must have locator. Now you can quickly identify the pipe location, thereby reducing the search area of the leak.

100% satisfaction guarantee... We are so sure that you will see the time saving benefit of the Pulsar 2000, we will let you return it for a full refund if you are not satisfied. If

you want to learn more about the Pulsar 2000 and our leak locating equipment, please call 1-888-752-5463 or e-mail jsmll@aol.com for a free demonstration video or CD and references of satisfied customers.

We have been using the Pulsar 2000 along with the XL2 fluid detector and Geophones since January 1989 in our leak locating business. Our leak locates are **accurate 95% of the time**, but I can honestly say, the line we trace is always there. Our equipment is user-friendly and requires very little training, as you will see on the video. Purchase the Pulsar 2000 line tracer, XL2 fluid detector and Geophones, and start locating leaks immediately.

WJTA-IMCA CONFERENCE AND EXPO SEPT. 9-11

The 2013 WJTA-IMCA Conference and Expo is scheduled for Sept. 9-11 at the George R. Brown Convention Center in Houston. Presentations include Waterjet Technology-Basics and Beyond, Sept. 9, and Boot Camp Sessions, Sept. 10-11. Featured boot camp topics include high pressure hydroblasting hose failure and life cycle analysis, hydroexcavation, refractory removal, grounding and bonding, manual waterblast efficiency, nozzle selection, robotic hydroblasting, waterblast safety, emissions-free industrial vacuuming and understanding how vacuum loaders work.

ENVIROSIGHT LAUNCHES VERISIGHT PRO WEBSITE

Envirosight launched a dedicated website (www.verisightcamera.com) for its VeriSight Pro digital push camera. The e-commerce site enables 100-, 200- and 300-foot models to be purchased by credit card or PayPal. The site also includes product information and applications.

MARTIN ENGINEERING, CCC GROUP FORM ALLIANCE

Martin Engineering and the CCC Group have partnered to design and manufacture conveyors for engineered transfer points. The companies will initially target mining and biomass applications.

PRIMELINE PRODUCTS NAMES REGIONAL SALES MANAGER

PrimeLine Products named Wesley Strong Southeast regional sales manager. He has 14 years of sales and service experience.



Wesley Strong

HONDA RECEIVES MARCOM AWARDS, DONATES GENERATORS

Honda Power Equipment, a division of Honda Motor Co., received two MarCom Awards for its computer-based dealer and distributor service training modules. Honda Engines received the Platinum Award for its maintenance course and Honda Marine received a Gold Award for its propeller basis course. The awards were presented by the Association of Marketing and Communication Professionals. Honda Power Equipment also provided Operation BBQ Relief with two of its Super Quiet Series portable generators. The relief effort cooks and caters meals for victims of natural disasters.

HAMMERHEAD RECEIVES INNOVATIVE PRODUCT AWARD

HammerHead Trenchless Equipment's 34-inch ramming hammer received the Joseph L. Abbott Jr. Innovative Product Award at the North American Society for Trenchless Technology Annual No-Dig Show.

DITCH WITCH PRESENTS SALES, SERVICE AWARDS

Ditch Witch presented Detlef Kaiser of German-based Tramann+Sohn with the 2012 Lowell Highfill Award, the organization's highest recognition for sales performance, and awarded Brent Zerr of Ditch Witch of Oklahoma with the Gold Ace Award for highest worldwide sales volume. Ditch Witch also awarded Josh Kennedy of Ditch Witch of Oklahoma with the Harold Chestnut Award, its highest recognition for service, and awarded Jeff Lone of Ditch Witch Midwest with its 2012 Service Manager of the Year award.

T-REX ADDS 35TH HYDROEXCAVATION TRUCK TO FLEET

T-Rex Hydro Excavation and Industrial Vacuum Services of Houston, Texas, added a 35th hydroexcavator to its fleet, with plans to add 14 more GapVax HV-55 hydroexcavators and 40 employees by year's end. T-Rex

provides non-destructive hydro and air excavation services through four offices in Texas, serving a growing number of projects from shale oil exploration and pipeline construction in the Eagle Ford and Permian Basin areas.

MTECH UPGRADES WEBSITE

MTech launched its upgraded website, www.mtechcompany.com. The site is designed to make scrolling and navigation of product photos and categories easier.

INSITUFORM AWARDED \$10.4 MILLION IN CONTRACTS

Insituform Technologies USA, a subsidiary of Aegion Corp., received two contracts valued at approximately \$10.4 million from the Metropolitan St. Louis Sewer District as part of the district's \$4.7 billion sewer system improvement program. The project includes installation of approximately 47 miles of cured-in-place pipe in small- and medium-diameter sewer pipelines in mostly residential areas. Work began in August and is anticipated to be completed in a year.

PIPE RESTORATION SERVICES RECEIVES AWARD, NAMED COMPANY OF MONTH

Pipe Restoration Services, a joint venture between Morrison Utility Services and U.S.-based Pipe Restoration Technologies, was named a UK Energy Innovation Award winner in the Best Innovation Implemented or Adopted by a Contractor category. The award was presented to PRS for adapting ePIPE, a technology initially introduced in the UK to eliminate lead and leaks in water and now being developed to extend asset life for gas riser systems. PRS also was selected Company of the Month by Buildings and Facilities News.

AQUATHERM RELEASES NEW LOGO, PRODUCT LINES

Aquatherm GmbH and its North American partner, Aquatherm North America, released a refreshed logo and new product lines. The German-based pipe manufacturer and supplier of polypropylene-random piping systems offers seven major product lines, with five available in North America. For the sake of unity and clarity, the Aquatherm product lines will be identified using a color-coded convention, originally tested in the U.S. market when Aquatherm's original piping product, Fusiotherm, was renamed Aquatherm Greenpipe. With the new naming, Aquatherm Greenpipe will become Aquatherm Green Pipe and Climatherm will become Aquatherm Blue Pipe. Aquatherm Lilac Pipe will remain unchanged.



aquatherm

VACUUM TRUCK RENTALS ADDS SEWER EQUIPMENT MODELS

Vacuum Truck Rentals added the Sewer Equipment Co. of America models 800 HPR ECO truck jet and 747-FR2000 ECO trailer jet to its rental fleet. Vacuum Truck Rentals has locations in Indiana, Louisiana, Massachusetts, Mississippi, New Jersey, South Carolina and Texas. They offer lease and rent-to-own options for the municipal and industrial markets.

LOGIBALL CELEBRATES 30TH ANNIVERSARY

Logiball celebrates its 30th anniversary this year. Founded in 1983, the company provides test and seal packers, reinforced multi-sized plugs and carrier packers for sectional liners, lateral cleaning equipment and specialized tools for the rehabilitation and maintenance of collection systems. 



**24 HOUR TURNAROUND - MIDWEST'S LARGEST FACTORY AUTHORIZED
REPAIR CENTER FOR GEN-EYE, GATORCAM & SEESNAKE**



ClogChopper™

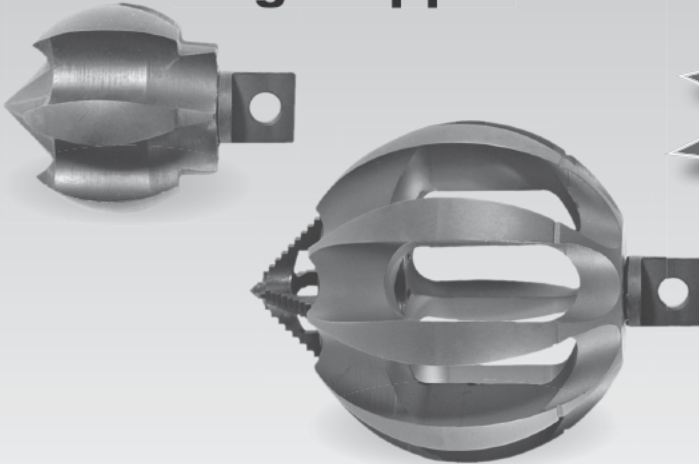

- Multi-function cutting tools
- Six self-sharpening blades
- Risk-free pipe damage
- Maneuvers around tight bends
- Safe cleaning on metal, plastic and clay pipes
- Variety of sizes
- Connector options for most drain cleaning machines

CALL FOR PRICING!

WAREHOUSE LIQUIDATION SALE

- Used Camera Kits Starting As Low As **\$500**
- G-I Reels
- G-I Monitor/VCR Combo Packages
- G-II Reels
- G-II Monitor/VCR Combo Packages
- G-II Locators
- G-III Reels
- G-III Monitor/VCR Combo Packages
- DVD Upgrades Available For Additional Charge
- J- 3055 Jetter Demo Models
- J- 3080 Jetter Demo Models
- J- 2000 (One Available, NEW In Box)

EVERYTHING MUST GO!
No Reasonable Offer Will Be Refused

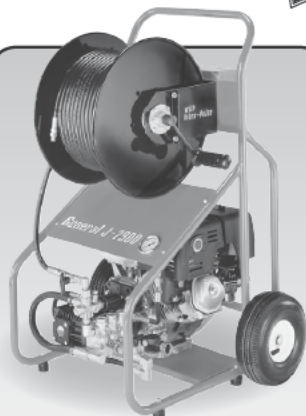

General J-2900
Basic Unit Machine Only

\$2745
FREE DELIVERY

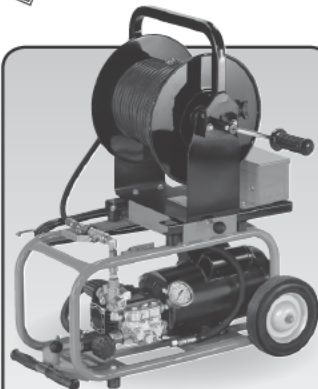

General J-1450
Portable Jetter
Basic Unit Machine Only

\$1540
FREE DELIVERY



Mini-Rooter XP™
Basic Unit – No cable cutters
or power feed

\$580
FREE DELIVERY



General Speedroooter 92™
Basic Unit – No cable cutters
or power feed

\$1160
FREE DELIVERY

Root killer prevents intrusion inside and outside sewer pipes

BY ED WODALSKI

Oblitiroot sewer line foaming root killer from Olvidium prevents root intrusion and stops root growth inside and outside pipes. The EPA-approved root killer contains dichlobenil as its active ingredient and won't foam until mixed, enabling its use in toilet bowls without the potential for overflow damage to tile or carpet.

"We made this so it won't foam until it's stirred, and it foams very slowly so you shouldn't have an accident," says Tim "Toby" Tobiason, product inventor and vice president of marketing and sales for Olvidium.

Oblitiroot contains a glue base that adheres to pipe surfaces, providing maximum effectiveness over an extended period of time.

"If you put any root killer down the line, including, at the start, this one, nearly 99 percent of it would drain away," he says. "We made this stickier and stickier during our preliminary tests and we got it so that if you put it in the toilet bowl, about 10 percent would stay in the sewer line."

Tobiason says he was able to further increase the retention rate by using a cable and cloth to apply the chemical.

"You dip the cloth fitting in the bucket of foam and send it down the sewer line, pouring the foam behind it. All this foam that would have been wasted and drained away hits the cable and stops," he says. "The water runs underneath it, then as you retract the cable it picks up the foam and puts it on as a coating of paint."

The cable-foam method also pushes the root killer into the joints of the pipe, creating a protective barrier against further intrusion.

"When you get that much root killer in the joints it solidifies and makes what looks like a piece of soft rubber," Tobiason says. "As long as that soft rubber is there with the dichlobenil in it, no roots will ever grow

in there. In fact, no roots will grow within 3 to 4 inches of it. So if you're going in blind and you can't see what's going on with a camera, the cable coating still lets you get the root killer pretty much everywhere and on everything."

Dichlobenil's vapor action stops root growth up to approximately 20 feet away, he says. When used in California orchards, the herbicide prevents shallow-rooted plants, such as grass, from growing without harming the deep-rooted fruit trees.

"If you get enough of our root killer in the first two feet of a sewer line, it can stop roots from growing up to 50 feet away because of the vapor," Tobiason says. "We anticipate that rubbery coating will stay there for up to two years, maybe more. If you get a lot in the joints, it should last up to five years."

A third form of application involves identifying root blockage inside a pipe and boring a 2-inch hole to the pipe joint and saturating it with root killer. "As this solidifies on the outside of the pipe, no roots can grow in anymore," he says. "With a 2-inch tube down there, all you have to do is reload it every few years. We also came up with the idea of a microchip to beep you each time it needs more root killer."

The root killer is available in three sizes: 1.6-pound bottle for 4-inch by 100-foot lines, 2.4-pound bottle for 6-inch by 100-foot lines, and 9.5-pound jug (approximately one gallon) for 8-inch by 100-foot lines. 877/747-3071; www.olvidium.com.



ARIES SIDE SCAN VIDEO CAMERA

The dual-viewing Side Scan Camera System from Aries Industries is designed for pipeline maintenance, inspection and rehabilitation in 6- to 48-inch-diameter pipe. The system offers synchronized playback, presentation of live video (MPEG format) and a flat, unfolded view

for quick pinpoint of pipeline discrepancies without having to stop and play to report each observation. 800/234-7205; www.ariesindustries.com.

ENVIROSIGHT DESK-MOUNT ROVER CONTROL

The DCX5000 Command Center from EnviroSight provides fingertip access to all ROVER X functions from a single interface. Twin proportional joysticks enable control of camera and crawler movement, while thumbwheels control illumination intensity, cruise speed, camera height and reel force. The 10-inch tilttable LCD touchscreen lets the operator drill down to deeper functions. 866/936-8476; www.envirosight.com.



MSA SENSOR FOR MULTIGAS DETECTORS

The SO₂/H₂S-LC XCell sensor for Altair 4X multigas detectors from MSA has a range of 0-20 ppm SO₂ and 0-100 ppm H₂S with 0.1 ppm resolution on both channels. The standard H₂S low concentration channel meets ACGIH recommendations for 1ppm TLV. The sensor provides pump tests in less than 10 seconds and full scan calibration in 60 seconds. www.msasafety.com.



RIDGID ADVANCED LITHIUM 18V BATTERIES

Advanced lithium 18V batteries from RIDGID are available in 2.0 Ah and 4.0 Ah sizes and have an operating range of 29 degrees to 158 degrees F. The 2.0 Ah battery, which comes standard with all RIDGID battery-powered press tools, can deliver 200 presses per charge, while the 4.0 Ah battery delivers 400 presses per charge. Both batteries have a lifespan of 400 to 500 charges. 800/769-7743; www.ridgid.com.



W.R. GRACE CHEMICAL GROUT

Gelacyl SR De Neef chemical grout from W.R. Grace Corp. is an acrylamide-free resin, designed for use in mainline and lateral grouting. The polyacrylate resin has no environmental labeling requirements and resists bacteria and fungi found in sewer systems. 800/732-0166; www.deneef.com.

HIGHWAY PRODUCTS PICKUP BED BOXES

High-side tool boxes for pickup trucks from Highway Products, available in sizes to fit all trucks, mount on bed rails and feature 1/8-inch thick marine grade aluminum construction. Theft-resistant T-handle stainless steel locks keep tools secure, while neoprene weather stripping keeps them dry. 800/866-5269; www.800toolbox.com.



NEXTRAQ DRIVER SAFETY TRACKING REPORT

The Driver Safety Scorecard GPS tracking report from NexTraq monitors and measures hard braking, quick acceleration, sharp cornering and excessive speed. The report provides a graphic ranking of the best and worst drivers, enabling managers to identify risky drivers and take action to eliminate aggressive driving, and reduce fuel costs, vehicle wear and insurance costs. 800/358-6178; www.nextraq.com.



CUSTOM DRILLED NOZZLES

SIX PACK KIT™



NOW OFFERING JETTING HOSE! CALL FOR A QUOTE

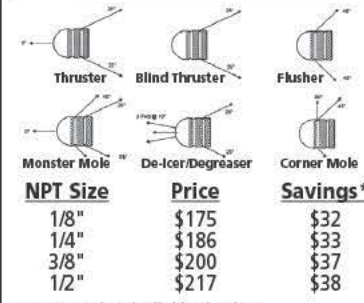

- Each nozzle is **custom drilled** to match your pump's flow and pressure specs for **optimized nozzle performance**.
- Custom drilling means **your choice of spray patterns**.
- Each nozzle is made with **heat treated 416 stainless steel** for superior corrosion and wear resistance, and rated up to 10,000 psi.
- Most orders shipped within **one business day**.
- **100% satisfaction guarantee**.

*Compared to individual prices

CALL TOLL FREE: 877-457-2782
North Royalton, OH 44133 • www.aquamole.com • Fax: 440-237-2987

Extra! Extra!

Want More Stories?

Get more news,
more information,
more features with

Online Exclusives

Exclusive online content
for *Cleaner*

www.Cleaner.com/online_exclusives



Cleaner Marketplace Advertising

Water Jets for rent



- Units from 4,000 to 40,000 psi, including convertibles
- 60-600 hp, diesel or electric
- Rent, buy or lease
- 6 convenient branches: MI, IN, NJ, LA, TX, CA

NLB Corp. 1-877-NLB-7996
www.nlbcorp.com

NEW & AFFORDABLE

AQUA SAFE SUIT



- UHP Protection
- Comfortable & Flexible

by: **CESCO**

Hose Shrouds

- Operator Protection Against Sudden Hose Leak Failure
- UHP Protective Fabric
- 48" Long Abrasion Sleeve
- Fits All Manufacturers
- Easy Installation

chris@aquamiser.com
1-800-394-4987



MY OL' DADDY CAN REPAIR YOUR SEWER CAMERA RIGHT THE FIRST TIME!

> We are an authorized service center for General Wire, Rotech, Vision and Ridgid.
> Your equipment is very expensive and we would be happy to supply references on our quality work. Just call Terry or Stan!

> We service push rod reels, cameras and command modules. We repair most brands.
> We understand when your equipment is broken, you are losing Big Bucks! We give fast and quality service.

Electronic Repair Co. • 205-836-0454 • servicewithasmile.com

Trailer Jetters Gas or Diesel

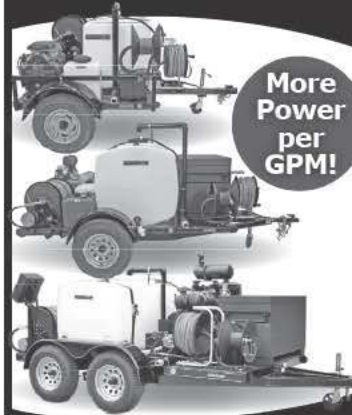

More Power per GPM!

AmericanJetter.com
866-9HI-FLOW

Advanced Work Horse

Advanced Workhorse nozzles utilize conical ceramic inserts to *Maximize Your Horsepower!*

Available through Vacall Toll Free 800-445-4752 or vacallindustries.com

AQUA BLAST™

Manufacturer Of High Pressure Cleaning Systems

Aqua Blast... Built to Last!

- Hot or cold water - electric or gasoline - diesel or natural gas - portable or stationary - truck or trailer mounted - we can do it all
- Specializing in custom-built units
- 2 GPM to 650 GPM - 500 PSI to 20,000 PSI - whatever size you need
- 1-year limited warranty
- Complete line of parts and accessories
- Unmatched service after the sale

50 years in Business.
800.338.7373
www.aquablast.com

Clean Out Plug Wrench

A wrench for nearly every size and style of clean out plug.

PROMO Code 7320

HeavyDutySupplies.com
888-745-7775

You Can Install Sewer and Water Lines (Without Digging A Trench)

Pipe Genies Do It All!
Ductile & Cast Iron, Clay & Concrete, ABS, PE & PVC

Pipe Genies Pull Any Pipe!
System Power From 20 Tons to 240 Tons!
(Rated for 1/2" - 30" Pipe)

Pipe Genies Work Anywhere!
The Most Compact Systems Available!

We have everything you need to get started making profits with pipe bursting!

www.TrenchlessAmerica.com
Toll Free 1 877 411 7473

Great Tips. Great Deals. Great Magazine.

Turn the page and stay up-to-date on the latest products, equipment and information for your industry.

Don't miss an issue - Subscribe today!
Call **1.800.257.7222**
or go to www.mswmag.com

WWW.PUMPERSHOW.COM

PUMPER & CLEANER ENVIRONMENTAL EXPO INTERNATIONAL

Indianapolis
FEBRUARY 24-27 2014
INDIANA CONVENTION CENTER

REGISTER TODAY!

T&T Tools, Inc.
800.521.6893



**CALL
 for a
 FREE
 Catalog**

Many styles
 Available

Insulated
 Soil Probes
 (for locating)

Heat-Treated
 Hooks
 (for covers, lids, etc)

www.mightyprobe.com



Cua Claws

A Simple Solution for
 Slippery PVC Pipe -
The Right Wheels
 We now resurface all makes
 of steel transport wheels

CALL JERRY AT 714-697-8697
www.cuaclaws.com



NEW!

**Get it ALL
 in one convenient
 eBook!**

www.cole-mart.com/cleaner

Cleaner magazine is written solely for
 professionals who service
 residential and commercial drain and
 sewer maintenance, cleaning and repair
 business along with industrial high
 pressure cleaning contractors.



DYE TRACERS
 Solutions
 for:
 • Infiltration
 • Septic Systems
 • Cross Connection
 • Leaks and more...

**BRIGHT
 DYES**
 Division of Kingscote Chemicals

NSF Certified to ANSI/ISO 9001

www.brightdyes.com • 1-800-394-0678

**ERICKSON
 Tank & Pump**

WE TAKE TRADES

509.785.2955
 CALL FOR UPDATED LIST OF
EQUIPMENT
WWW.ERICKSONTANK.COM

Masport®
 PUMPS & QUALITY COMPONENTS
 800 Rd. P5 S.W. / Quincy, WA 98848
 fax: 509.785.3770
 e-mail: sales@ericksontank.com
 "TANKS" FOR YOUR BUSINESS!

Over 25 years
 of building
 quality equipment

HotJetusa®
 DRAIN LINE JETTING EQUIPMENT

**Most Versatile Jetter
 On The Market!**

• 35 HP Vanguard
 • Remote Control
 • Cleans Drains from 2"-8"+

On Sale For Only
\$24,995!

Fully loaded! Call for details!

1-800-213-3272
www.hotjetusa.com

**Waterblaster
 Rentals & Sales**

Houston, Texas

Boatman Industries

1K to 50K psi
 60 hp to 1000 hp
 Waterblasters & Accessories
 Used Equipment Sales

713-641-6006
www.boatmanind.com

**Manhole Rehabilitation
 Equipment**

Portable, Trailer Mounted, Spincasters,
 Individual Components, Accessories
 for Cementitious and Epoxy products.

**We have what you need.
 Call us at (800)356-9023.**

**Affordable
 UHP Waterjetting
 is Here...**

Quality waterjetting pumps, sapphire
 nozzles, jetlances & UHP hose.

All Jetting Technologies strives to manufacture a
 product that will make your job more productive,
 safer and more profitable

Made in the USA

**All Jetting
 Technologies, Inc.**
 772.286.1218 F: 772.286.0069
 E: info@alljetting.com www.alljetting.com

**DYNAMIC
 REPAIRS**

We Repair:
 General Wire, Ratch, RIDGID, Hathorn Corp.
 Electric Eel, GatorCams, Vision Intruders
 and Vivax Inspection Cameras,
 Locators, Command Modules and Cables

**New & Refurbished Inspection
 Equipment For Sale**

**Rental Equipment Available
 Daily & Weekly Rates**

Ask
 About
 Our
 48-Hr.
 Turn
 Around
 Time

**INSPECTION CAMERAS
 ARE OUR
 ONLY BUSINESS!**

973-478-0893

DYNAMIC REPAIRS
 40 Arnot St., Unit 20
 Lodi, NJ 07644
dynamiceablerepairs@yahoo.com
www.dynamicrepairs.net

**Out With The OLD...
 In With The NEW!**

Replace **Water Services** in
 Less time for Less Money!

WEDGE

Galvanized
 Copper
 PE

Factory Direct
SPECIALS
 On Now!

Split or Pull Out Copper,
 Galvanized and Plastic Pipe.

THINK TRENCHLESS!

Call us toll free:
1-888-737-3668
 Or visit us at:
www.footage.com

**Footage
 TOOLS**
 Tools made for work!

**CONFINED SPACE
 ENTRY PACKAGE ONLY \$2,995**

• 4-Gas Air Monitor
 • 7' Tripod
 • 3-Way Fall Protection
 • Work Winch
 • Full Body Harness

Add a Blower with 15' of duct for only \$350!
 Add a 5 Minute Escape Respirator for only \$500!

MECH. 800.362.0240
www.mtechcompany.com

**Follow Cleaner
 on**

www.facebook.com/CleanerMag twitter.com/CleanerMagazine

classifieds

see photos in color at www.cleaner.com

BUSINESSES

WWW.ROOTERMAN.COM. Franchises available with low flat fee. New concept. Visit website or call **1-800-700-8062 x26**. (CPBM)

Central Florida septic/sewer service company in business for over 20 years. All equipment, accounts, office and yard. Staff in place. SepticForSale.com Bill 407-641-4775 (C08)

West Texas Plumbing Business for Sale: In business for 60 years. Owner retiring. For more information, e-mail drip001_2@att.net. (C08)

COMPUTER SOFTWARE

FreeServiceReminderSoftware.com, FreeServiceDispatchSoftware.com, FreeRouteManagementSoftware.com. (CBM)

DRAIN/SEWER CLEANING EQUIPMENT



2005 Sterling Aquatech combination sewer cleaning truck: 10-yd. body, 624 Roots PD vacuum blower, General pump 35 gpm @ 2000 psi, 10-yard debris body, 28,153 miles.\$90,000

972-938-1905 TX
khtrucks.com

C08

Used and rebuilt cable machines in stock: RIDGID K-7500, K-40, K-60, K-1500, Roto-Rooter #55, WXL #C, Spartan #1064, #300, #100, Electric Eel model #C machines. The Cable Center: 800-257-7209. (CBM)

General Wire models J-3055, J-3080, and J-2000; Spartan #717; Electric Eel gas jetters. The Cable Center: 800-257-7209(CBM)

DEWATERING



2013 De-Cant Tainer 15YD-RB-NCW: 2013 new 15yd dewatering vacuum truck special filter box, roll-over tarp system with quick release bows, filter media, loading manifold, drain and wash-out ports.\$24,500

For more info call
863-984-8994

C08

HAZARDOUS WASTE UNITS

New 3,200 U.S. gallon, carbon steel, DOT certified 407/412 vacuum tank; dump type with full open rear door and a Presvac PVB-750 vacuum-pressure pump installed on a 2014 Peterbilt 348 cab and chassis. (Stock #13563A-B) **www.VacuumSalesInc.com, (888) VAC-UNIT (822-8648).** (CBM)

JETTERS-TRAILER

1992 FMC Trailer Jetter: 35gpm @ 2,000psi, 600-gallon water tank. Good tires. Recently inspected. Approx 500' 3/4 jetter hose. Recently painted. Unit is ready to be put to work. Continental diesel engine. \$8,500. Please call me with any questions: Patrick 484-535-2550. Shipping to be arranged by buyer. (C08)



Xtreme Flow Hot/Cold Jetter! Model #HJ2TA8536, tandem axle trailer, 35 hp Vanguard 8.5 gpm @ 3,600 psi, 325-gallon water tank, 300' hose, General Pump. List \$34,995. On sale for \$29,995. Fully loaded!

800-213-3272
www.hotjetusa.com

CPBM



2007 US Jet 4018 (wireless) 300 gallon water, 18 GPM at 4000 PSI. Hatz silent diesel pack. Super clean, work-ready unit.\$19,888

1-800-627-0778

C08



Harben 4018 300 gal water 18 GPM at 4000 PSI. Hatz silent diesel pack. Clean, work-ready unit.\$17,300

1-800-627-0778

C08

1999 O'Brien Trailer Jet with 165 original hrs. 4-cylinder diesel engine, 800-gallon plastic water tanks, Myers 65gpm 2000psi pump, 500 feet of new jet hose, new white paint. Pictures at www.empireequip.com \$23,500. 714-639-8352 (CBM)

JETTERS-TRUCK



2009 Ford PipeHunter: Giant pump 29 GPM @ 3000 PSI. 3/4" jetting hose. 700-gallon Poly water tank. John Deere rear engine.\$38,500

972-938-1905 TX
khtrucks.com

C08



2008 Ford F-550 PipeHunter 7844TMV: 3/4" Jett hose. Giant pump 14.2 GPM @ 4000 PSI. Tuthill blower. John Deere rear engine. 294 hrs.\$36,500

972-938-1905 TX
khtrucks.com

C08

2008 Ford F-750 PipeHunter: Giant pump 47.5 GPM @ 3000 PSI. 1500-gallon poly tank. 1/2 and 3/4 inch hose reels. John Deere rear engine. 972-938-1905 khtrucks.com \$37,500 (C08)

Jack Doheny Supplies Inc. offers a full range of late model combo units and DOT industrial vacuum loaders. Call us @1-800-3DOHENY. (CPBM)

Skid unit — US Jet 6,000/18 and 3,000/36. 2 reels, 600-gallon water tank. 480 hours on unit. \$14,000. Call 605-996-1765. (C08)

PIT SHOT LINER

Complete CIPP Kit



Hot Water

Productivity Booster

Fill line up just once with hot water at 100°F for a near instant cure. Say goodbye to recirculation headaches!

Includes Pre-Measured Resin, Col Tube & Liner.

Kit available for 40' to 164' run lengths. Fully illustrated instructions included.



866 535 3694 | www.gadmon.com

CIPP THAT FITS!

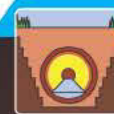

PIT SHOT LINER

Complete CIPP Kit

Transition

One Size Fits All

Reduce offcut waste! This kit's liner can expand to diameters within a 4-6" range.

Includes Pre-Measured Resin, Col Tube & Liner.

Kit available for 40' to 164' run lengths. Fully illustrated instructions included.



866 535 3694 | www.gadmon.com

CIPP THAT FITS!

2006 GMC TC6500 cab and chassis with Pipe Hunter trunk mounted jetting unit, 3,000 psi @ 50 gpm with a 1,000-gallon water tank, rear mounted hose reel with Jet Eye Camera System, **6,800 original miles, like new. \$89,000 sale price.** (Stock #13234V) www.VacuumSalesInc.com, (888) **VAC-UNIT (822-8648)**. (CBM)

JET VACS



2000 Sterling Vactor 2100: Cat motor - 10-speed tandem axle, 1,500-gallon water capacity, 18" Roots blower, 80gpm @ 2,500psi Rodder pump, 15yd debris tank. Ready to work \$85,000
954-782-6752, FL C08

2006 2112 Vactor on a Sterling LT7501; CatC7 engine. 60,000 GVW. Rebuilt Roots 824PD blower, 80gpm 2,000psi pump. Pictures at www.absolutelinetechologies.com \$145,500. Call 352-409-3284 (C08)

1996 L8000 Vac Con: Single-axle. 2-stage fan. 5-yard box. Runs great. Auto transmission. Used as a back-up truck and it needs to go to work. \$50,000 shanestambaugh@hotmail.com FL (C09)

2003 Vactor 2110PD on a Sterling LT7500. Pump 80 gpm, 2,500 psi. Roots 824 blower. 1,500 gallon water capacity. New paint. Was a city-owned unit. Pictures at www.empireequip.com. Price \$129,900. 714-639-8352. (CBM)

2006 Peterbilt Vac-Con; 2003 Sterling Vac-Con. Call Joey for information and prices 904-284-2141 (C08)



2006 Peterbilt Vac-Con: 80 gpm, 3-stage fan, 12-yard debris tank, 65,000 miles. \$135,000
Call 1-877-389-2227 IN CPO8



2006 International Vac-Con: 80 gpm, 3-stage fan, 12-yard debris tank, 73,000 miles. \$135,000
Call 1-877-389-2227 IN CPO8

2007 Aquatech B5 on a Sterling LT7500; CatC9 engine with 40,300 miles. 60,000 GVW. Roots 824PD blower, 80gpm 2,000psi pump. 500 ft. new jet hose. Was a city-owned unit in excellent condition. Pictures at www.empireequip.com. \$134,500. Call 714-639-8352. (CBM)

Vac-Con V390LHA combination unit with Roots 827 blower, 1999 International Model 2554 cab and chassis. (Stock #3918C) www.VacuumSalesInc.com, (888) **VAC-UNIT (822-8648)**. (CBM)

LEASE/FINANCING

North Star Commercial Credit: Commercial loans for trucks or equipment. Flexible purchase programs to fit your budget. 21 years in the industry. Contact **Tom Myers - 877-804-2274**. (CBM)

Capital Connection is the leader in sanitation equipment financing. From Jetters to toilets, cameras to sewer trucks; we've been helping companies grow for over 23 years. Call today and let us help you acquire the equipment you need to grow your business. Jeff can help you. Pease call 808-214-4456. (C08)

MISCELLANEOUS

Best Reasonable Offer: 1. One pallet of 2" air diaphragm pumps plus electrical pump and three pallets of air supply, suction, and discharge hoses as a package. 2. Boiler Cleaning Equipment: aluminum sections for suspended rotary unit, two hydraulic motors, electric/hydraulic pump...package. 3. 4" air diaphragm pump. 4. Various components for abrasive jet cutting: garnet feed hopper, hyd. motor, rail and etc. 5. Hydrodemolition travel assembly... mounts on 4-inch rails... left, right, forward, reverse. Pictures available. willhamilton01@gmail.com 617-680-4569. All items: As is, where is... you ship. (C08)

Chemical Cleaning (tt) Trailer: Main tank capacity 1,350 gal., designed for caustic material. 2 CAT pumps, 2 heat exchangers, (2) 50-hp electric motors, (2) 425-gal. tanks. Tanks and piping all stainless. Extra pumps. Has chemical hoses and pumps and reels. 617-680-4569. (C08)

Titan 8000 series, high performance, RIDGID 8000 Zero-Gravity. The Cable Center: 800-257-7209. (CBM)

NOZZLES

SAPPHIRE NOZZLES for UHP, laser-etched, heat treated, excellent quality, fantastic savings! 772-286-1218. info@alljetting.com; www.alljetting.com. (CBM)

PARTS & COMPONENTS

US Jetting provides aftermarket rebuilding services and **replacement parts for Harben® pumps**. Low prices, fast response. Why pay more? Call today. 1-800-538-8464, ext 25 or 18. (CBM)

PIPELINE REHABILITATION

Permaliner inversion system, complete installation system purchased 2012. Like new condition. System includes materials and multiple inversion heads from 3" to 6". \$26,500. 626-221-5379 ask for Joel. (C10) One trade-in model of Pipe Genie heavy-duty, pipe bursting equipment. Excellent condition, looks new, 30-ton, 100 feet cable, full 2-year warranty. 877-411-7473. (CBM)

POSITIONS AVAILABLE



WORK CLOSE TO HOME! We're looking for experienced CCTV Operators (PACP-certified), Cleaner Operators, and CIPP liner installers in the Raleigh-Durham NC area. These positions include competitive pay and per Diem, company-paid training, and real advancement opportunities for the right candidates. Contact Ray Douberly today at 912-647-2847 extension 233. Southeast Pipe is an Equal Opportunity Employer and a Certified Drug-Free Workplace. C09

Pearpoint Inc., an SPX Brand, is currently seeking a sales professional in the Southeast region for our inspection product line. Experience in pipeline inspection and/or product sales through distribution channels for the utilities, municipal or construction markets desired. Remotely based anywhere in southeastern US. Salary plus 50% commission plan. Visit our career site to apply. <http://spx.avature.net/Careers/JobDetail/Atlanta-Georgia-United-States-Area-Sales-Manager/1357> (C08)

PIT SHOT LINER

Complete CIPP Kit

Tropical

No Sweat System!
For those working in 90°F and above. Specially retarded resin to give up to 3 hours working time.

Includes Pre-Measured Resin, Cal Tube & Liner.
Kit available for 40' to 164' run lengths. Fully illustrated instructions included.

866 535 3694 | www.gadmon.com CIPP THAT FITS!

CLEAN OUT PATCH

CIPP Patch Kit

Standard

Save \$\$\$ on our Jumbo Kit
The only patch solution available in convenient kit form but sold at discount bulk pricing!

Includes Pre-Measured Resin, Cal Tube & Liner.
Kit available for 2' to 40' lengths. Fully illustrated instructions included.

866 535 3694 | www.gadmon.com CIPP THAT FITS!

POSITIONS AVAILABLE

GapVax, Inc., a nationally recognized manufacturing business, is seeking a talented, highly motivated individual to fill a full-time Sales Position in the Midwest (Iowa based preferred) region. GapVax is the leading manufacturer of industrial and municipal vacuum units and hydroexcavation units in the United States. We provide the most reliable, comprehensive, and efficient mobile vacuum units in the industrial and municipal markets. Specifications of the position are listed on our website, www.gapvax.com, click on the Now Hiring link in the left hand column. Send resumes to Lthomas@gapvax.com or 575 Central Avenue, Johnstown, PA 15902. (CPMGBM)

Waterblasting Technicians - Tampa, FL. Mechanically inclined, OT/Out Town Travel/Pass Drug/Background Screens. EOE. Resumes to Dennis Braswell: dbraswell@blasters.net or call 813-985-4500. www.blasters.net (C08)

POSITIVE DISPLACEMENT BLOWERS

(2) New Sutorbilt PD blower, model GAFMBPA catalog no., 6 mp. \$2,500/each or \$4,500 for both. 714-639-8352. Pictures at www.empireequip.com. (CBM)

PRESSURE WASHERS



NEW pressure washer trailer.... JUST ADD WATER! \$7,995. Hot water skid, (3000psi, 4.8gpm) on a 200-gallon trailer with stainless hose reels. Other configurations available. Contact Hydro Tek for a local distributor.

800-274-9376
www.hydrotek.us C08

PUMPS

Honda model WP40X, 8 hp, 4" with hoses. Honda 4 hp, 2" pump with hoses. The Cable Center: 800-257-7209. (CBM)

Buy & Sell all makes and models, **new & used** vacuum pumps & high pressure water pumps, and good used replacement parts. Call for an inventory sheet and save. www.VacuumSalesInc.com, (888) VAC-UNIT (822-8648). (CBM)

RENTAL EQUIPMENT

Liquid vacs, wet/dry industrial vacs, combination jetter/vacs, vacuum street sweeper & catch basin cleaner, truck & trailer mounted jettors. All available for daily, weekly, monthly, and yearly rentals. **VSI Rentals, LLC, (888)VAC-UNIT (822-8648) www.vsirentalsllc.com.** (CBM)

SERVICE/REPAIR

Dynamic Repairs - Inspection Camera Repairs: 48 hour turn-around time. General Wire, Ratech, RIDGID, Electric Eel Mfg, Gator Cams, Insight Vision, Vision Intruders. Quality service on all brands. **Rental equipment available.** For more info call Jack at 973-478-0893. Lodi, New Jersey. (CMPBM)

www.servicewithasmile.com **Sewer Cam Reel and Camera Repair: Authorized for General Wire, Ratech, Vision & Ridgid. Quality service on all brands. Need more info? Just call Terry or Stan. Electronic Repair Co., Birmingham, AL 35206. 205-836-0454; email: part@servicewithasmile.com.** (CBM)

SEPTIC TRUCKS

Many low mileage used trucks available. Under CDL. www.pumpertrucksales.com. Call JR. @ 720-253-8014, CO. (PBM)



1999 International 7400: 1999 International 2554 with a Vac-con model V312/LHA 1300. 10-ft. telescoping boom, articulated hose reel, new 3-stage fan. Rebuilt pump 60gpm @ 2000psi. 69,458 miles.....\$80,500

1-800-349-8000 C10

TRUCKS (MISC.)

2000 International DT4900 tanker truck: Auto. trans. 3,500-4,000-gallon tank. 125,000 miles. Well maintained. Good shape. \$21,000. Cortez, Colorado 970-565-3962. (C08)

TOOLS

T&T Tools: Probes, hooks. Probes feature steel shafts with threaded and hardened tips. The insulated **Mighty Probe™** tested to 50,000 volts. **Top Poppers™** open man-hole covers easily. Free catalog. www.TandTtools.com. Phone 800-521-6893. (CPBM)

Ritchie Yellow Jacket Recovery System & BULLET 7 cfm pump. The Cable Center: 800-257-7209. (CBM)

SOLD

Reach over 26,000 potential buyers each month when you list your equipment in the classified section. Plus, your listing is placed automatically online at the *Cleaner* website.

That's two ways to move your equipment out of the yard!

Sell your
equipment in
Cleaner
classifieds

Why wait?

Go to
Cleaner.com/classifieds/place_ad

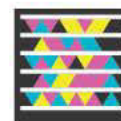

Scan the
code
with your
smartphone.

Bosch Brute hammer drill with cart irons. The Cable Center: 800-257-7209. (CBM)

RIDGID model #300 with stand, RIDGID stand vises, RP 330 ProPress kit. The Cable Center: 800-257-7209. (CBM)

TV INSPECTION

2007 EnviroSight CCTV trailer with Rover 125 & 225, Wincan software. Lots of extras. Call for pictures and more info. 801-971-5385 api.inc@netzero.com. (C08)

IBAK TV Van. Please go to www.cctvvan.com. (C08)

Lots of Aries camera equipment for sale: 1 Pathfinder Saturn system with 1 TR3300 and 1 TR3400 with large line kit, PE3500 zoom camera and full set of tires, re-term kit and misc nuts and bolts \$60,000. 1 Pathfinder Saturn system with 2 TR3300 tractors, PE3300 non-zoom camera and a set of tires \$25,000. 1 2 PE3600 with pathfinder adapter \$14,000. Package deal for everything. Call or email Kyle 515-360-8582 kyle@accujetiowa.com (C10)

Used and rebuilt camera kits in stock: RIDGID Mini Compact, Mini Color, Standard Self-Leveling, General Gen-Eye I, II and III, Aries Seeker, and SRECO kits. The Cable Center: 800-257-7209. (CBM)

CUES K2 SYSTEM: Steerable Compact Pipe Ranger (CPR), OZ3 camera, 1000' gold cable, auto cable reel, CPU, CCU, wireless controllers, six different wheel sets, two different wheel spacer sets, tool and manual. Like new (app. 40 hours) at 20% off list. Call 866-936-8476 or emailoffice@envirosight.com.(CBM)



2007 Freightliner MT45: CCTV Aries 2007 Freightliner: Diesel pipeline inspection step-van with brand new command center, never been used, fully loaded sewer TV system in 18' step-van. Portable pathfinder, pan and tilt, Badger, LETS lateral launcher, pole camera, thermal image camera, DVD/VCR, PipeTech software, compressor, restroom, sink, generator, winch, plus much more! Finance\$199,999/OBO.

925-784-2837, CA CBM

1999 E-450 V10 Cues CCTV; Cues Inspector General portable CCTV unit. Call Joey for information and prices 904-284-2141 (C08)

1998 CUES Mainline TV System: GMC Savanna 3500, CUES with Pro-Data on-screen titler, Honda generator, Sony combo DVD/VHS, 1,700' of M/C cable, pan & tilt camera with shorty transporter. \$29,500. 608-835-7767, WI. (CBM)

VACUUM LOADERS

2013 Western Star cab and chassis, Power Vac 5300, 3,250 U.S. gallon, carbon steel DOT 407/412 regulations vacuum tanker with a Hibon PD blower, 5300 SCFM with vacuum to 28" mercury. Dump Type with full open rear door, and a Presvac PVB 750 vacuum-pressure pump. (Stock #13518V) **www.VacuumSalesInc.com, (888) VAC-UNIT (822-8648).** (CBM)



Immaculate 2008 International Guzzler Ace: 5,000 blower hours, 115,000 miles. New front floater tires, sludge pump, wash-down system. New filter bags, REGEN warning system.\$220,000

502-594-2101 SC C08

1988 Ford with Guzzler body. Stainless box and 12-yard capacity. New silencer and rebuilt blower. Electric blowdown does not work. \$21,500. Runs and drives and sucks. Holiday, FL shanestambaugh@hotmail.com (C08)

WANTED

Wanted to Buy: Vactor 2100's and late model Guzzlers. Cash. 800-336-4369. (CPBM)

Wanted: 2-stall restroom trailer with showers. Any condition. Please call 541-297-4295. (C08)

WATERBLASTING

40,000 psi Sapphire Nozzles, UHP hoses & replacement parts. Excellent quality & prices. 772-286-1218, info@alljetting.com, www.alljetting.com. (CBM)

Gardner Denver T-375M: Bare Shaft pump. Gardner Denver T450M Bare Shaft pump NLB 20-200: 12 gpm @ 20,000 psi. Gardner Denver LC-1500: 390 gpm max, 15,000 psi max. NLB 36-200 6 gpm @ 36,000 psi. HT-150S 25 gpm max 10,000 psi max, Shell Side Machine, Wheatley 165: 30 gpm @ 10,000 psi, Wheatley 165: 17 gpm @ 20,000 psi. Wheatley 125 with aluminum bronze fluid end. Boatman Ind. 713-641-6006. View @ www.boatmanind.com. (CBM)

WATER JETTING EQUIPMENT: We sell, repair and retrofit water blasters. Visit us at: www.waterjettingequipment.com or phone 714-259-7700. (CBM)

Featured In An Article?

We provide reprint options

POSTERS
Starting At
\$35

Sizes: 24" x 30" & 36" x 45"

LASER REPRINTS
Starting At
\$10

ELECTRONIC REPRINTS
Starting At
\$25

Order through our website
www.cleaner.com

What's Your MONEY Machine?

Do you have a go-to service vehicle or high-tech workhorse tool that conquers many jobsite challenges?

Let us know about it at editor@cleaner.com and we'll consider highlighting your most valuable performer in our Money Machines feature.

Cleaner



It's black and white.

In every issue of *Municipal Sewer & Water*, you'll read all about sanitary sewer, stormwater and water system professionals. You'll discover:

- Who are the innovators in system repair and maintenance
- How they make sound decisions that improve service and save money
- What tools and technologies drive efficiency and performance
- Where to go to find the latest equipment and advice

No gray area here.

Municipal Sewer & Water has it all. And it's **FREE**.

Start your subscription today at mswmag.com
or call 800-257-7222.

GapVax®

888-442-7829

WWW.GAPVAX.COM



#1 CHOICE

Industrial Vacuum Equipment



UPCOMING SHOWS:

Sept. 9-11 WJTA-IMCA Expo - Houston, TX

Sept. 12 PA SAFETY DAYS - Monroesville, PA

Sept. 18-19 South Texas Oilfield Expo - Corpus Christi, TX

Sept. 24-26 Tri-State Seminar on the River - South Point, NV



THE WARRIOR. THE SOLDIER.

NOW REPORTING FOR DUTY.



Spartan Soldier



Spartan Warrior



SPARTAN
FOR TOUGH CUSTOMERS.
SINCE 1943

Introducing the industry's sleekest, quietest trailer jets ever. Spartan's fully enclosed, 4,000 PSI Warrior and stealthy 3,000 PSI Soldier feature exclusive soundproofing technology for engine noise below OSHA's strict standard for mandatory hearing protection. What's more, both come packed with all the power and performance you expect from the most trusted name in the business. Spartan. Innovation comes standard.



Pop the hood: Uncover all the hard-hitting features and specs at spartantool.com

CONTACT US TODAY | 800.435.3866