

FOR RESIDENTIAL, MUNICIPAL AND INDUSTRIAL CLEANING CONTRACTORS

Cleaner



**SHOW
ISSUE**



The Old Is New Again

United Industrial Services prospers in a time of high fuel prices and environmental awareness

PAGE 46

COLE PUBLISHING INC.
1720 MAPLE LAKE DAM RD.
PO BOX 220
THREE LAKES WI 54562

CHANGE SERVICE REQUESTED

PRSTD STD
U.S. POSTAGE
PAID
PERMIT NO. 659
Bolingbrook, IL

MONEY MANAGER

Parking your cash profitably

SAFETY FIRST

A ban on driving while phoning?

TECH PERSPECTIVE

Maintaining your computers

Take Clogged Drains by Storm

Now available with optional variable speed reel controller



Booth 3147



**J-2512
TYPHOON**

General's water jetters give you the power, flow, and toughness you need.

The **J-2512 Typhoon** trailer jet blows away blockages in big lines and long runs. 12 gallons a minute storm down the line at a powerful 2500 psi to blast lines clear of grease, sediment and debris. A 200-gallon holding tank carries enough water to handle remote applications where access to water is limited.

The Typhoon features a 24 hp Honda engine, 400 ft. jet hose reel and 150 ft. supply hose reel mounted at the rear of the unit, and a lockable tool box with engine controls mounted inside.

Standard equipment includes electric brakes, safety strobe light, rear fold-down stabilizer jacks, retractable hose guide arm, and antifreeze system.



**J-2512
TYPHOON**

With its 3000 psi, 5.5 gpm pump, the **J-3055** has the thrust to pull the hose down long runs, the pressure to cut through tough grease deposits and the flow to flush them away. In fact, the J-3055 has the highest flow rate available without requiring a holding tank.



J-3055

The **J-2900** is light, maneuverable, and delivers a strong performance at a very reasonable price. This compact, rugged unit delivers 3000 psi at 4 gpm. All General's jets have Vibra-pulse® on-demand to help slide the nozzle around tight bends and propel the hose down longer lines.



J-2900

General
PIPE CLEANERS
www.drainbrain.com

For more information on all of our water jets, visit www.drainbrain.com or call us at 800-245-6200 or 412-771-6300.

The toughest tools down the line.™

Less Noise

Vac-Con's larger capacity hydrostatic pumps allow the system to perform at a much lower RPM which means quieter operation, a healthy benefit for operators and community residents around the world.



Less Exhaust

Because of the efficiency of our hydrostatic drive systems, Vac-Con machines use less fuel, which means lower cost...and less exhaust.

Less Fuel

Vac-Con's exclusive 3-Stage Centrifugal Compressor operates at a performance level that loads material faster than the competition. This equals Less Time on the job which means Less Fuel is used.

Less Water

Vac-Con's available high pressure/low volume water systems conserve water.

We Were "Green" Before It Was Even Called "Green"

VAC-CON MACHINES HAVE BEEN "GREEN" FOR MORE THAN 20 YEARS.

Vac-Con is proud to be a leader in the worldwide environmental industry.

We have been manufacturing products that assist public and private entities in maintaining water collection systems and treatment facilities for more than two decades. We can all help assure that the world's potable water supplies are preserved for future generations simply by not wasting or polluting this precious resource. *Think high pressure/low volume!*

VAC-CON MACHINES – LEADING THE INDUSTRY IN "GREEN" INITIATIVES.



A HOLDEN INDUSTRIES Company

www.vac-con.com

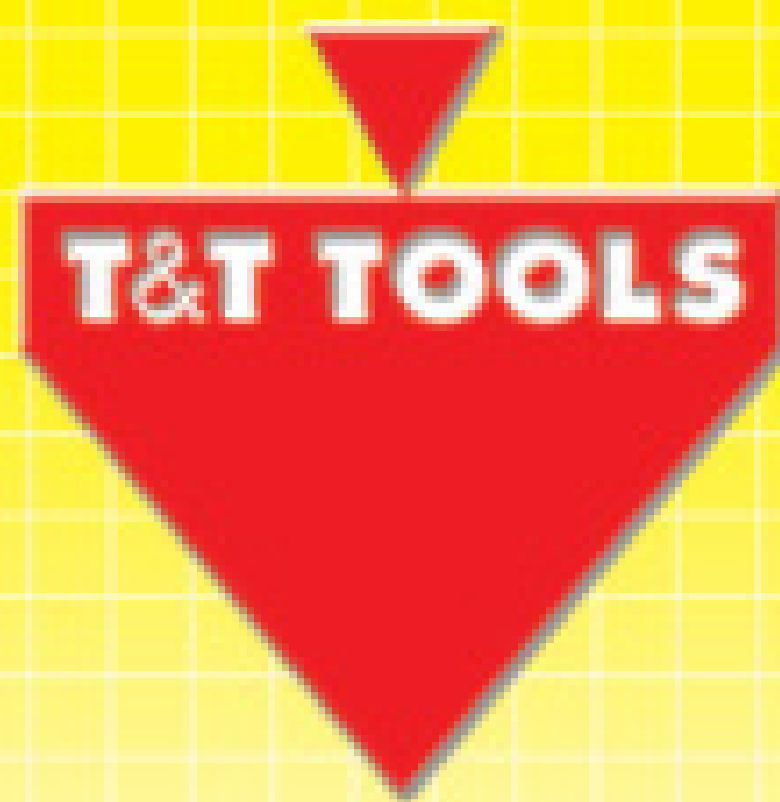

T&T Tools, Inc.

Fax: 800.521.3260
Email: sales@tandttools.com



800.521.6893

www.MightyProbe.com



Call for a FREE Catalog

Call for a FREE Catalog

HOOKS...

- > Several different styles of heat-treated hooks are available
- > Top Poppers are great to open manhole covers
- > The Handy Hooks allow two handed use

PROBES...

- > Insulated, standard, and specialty soil probes
- > Metal shaft sizes: 3/8" round, 3/8" hex, or 7/16" hex
- > Replaceable tips are threaded on and hardened
- > A "slide" allows the handle to pound the shaft into the ground

Trap-Cleer

Solutions for all Waste & Grease Problems

2009 Stimulus Package

Call Today!



Limited Time Only!

BEST PACKAGING - BEST PRODUCTS - BEST PRICE



Discover Marketing Secrets to More Pump-Outs

1-800-223-3083

Call Today for Your **FREE** Sample



Trap-Cleer

Lenzyme

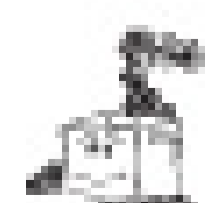

Vac-Con® Owners

Inlet/Outlet Seals ~ Rear Door Seals

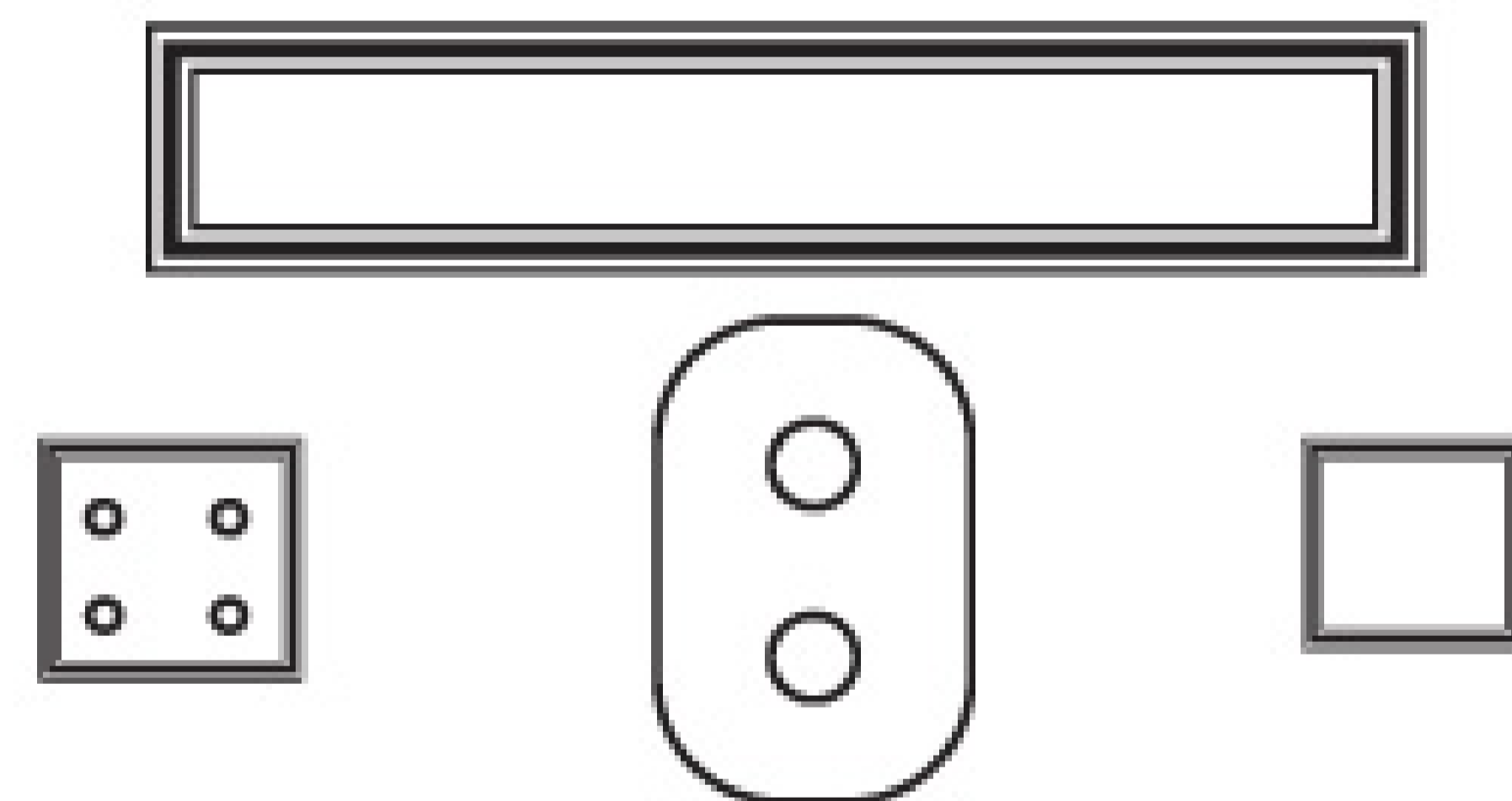

Vac-Con® #	Description	Size	Cost
690-0848	Inlet Seal	13"x11-5/8"	\$36
690-0847	Outlet Seal	10-1/4"x9-1/2"	\$32
690-0440	Vac Breaker Door Seal	7-1/4"x8"	\$22
690-0444	Vac Breaker Lid Outlet Seal	31-3/4"x4-1/4"	\$24
690-1179	Rear Door Seal	282"	\$180

All Of The Above Exceed Manufacturer's Specs.

Call Today & Save \$\$\$

In Stock For Immediate Delivery



Toll Free: 800-365-6583
www.cloverleaftool.com

Full Catalog Online with Prices

SARASOTA, FLORIDA • PHONE: 941-739-0707 • FAX: 941-739-0001



"Pipeline/Sewer Cleaning & Maintenance Equipment For Jetters & Jet/Vacs"

Pan/Tilt Lateral Launch *Crawls 300', Extends 100'.*



SuperVision™ SAT crawls 300' down lines 6" and larger, and then pushes its camera 100' into laterals as small as 3.5". Its auto-leveling camera pans and tilts to capture sidewall detail, and is pushed by force-sensing wheels designed to prevent cable damage. Easy to use and maintain, the system integrates with any existing SuperVision™, adding only a small reel alongside the primary crawler reel.

Digital Side-Scanner *Images Pipe Walls on the Fly.*



DigiSewer™ simply attaches to an existing or new ROVER™ crawler, making pipe inspection's fastest-growing technology both less expensive and exceptionally versatile. DigiSewer™ captures footage at up to 70 fpm without stopping to pan, tilt or zoom. It generates flat scans that can be reviewed and annotated far quicker than video. And because it leverages ROVER's™ steerable 6-wheel drive, DigiSewer™ scans even the most difficult lines.

Hydro-Powered Cutter *Delivers 5X Torque, 3X Productivity.*

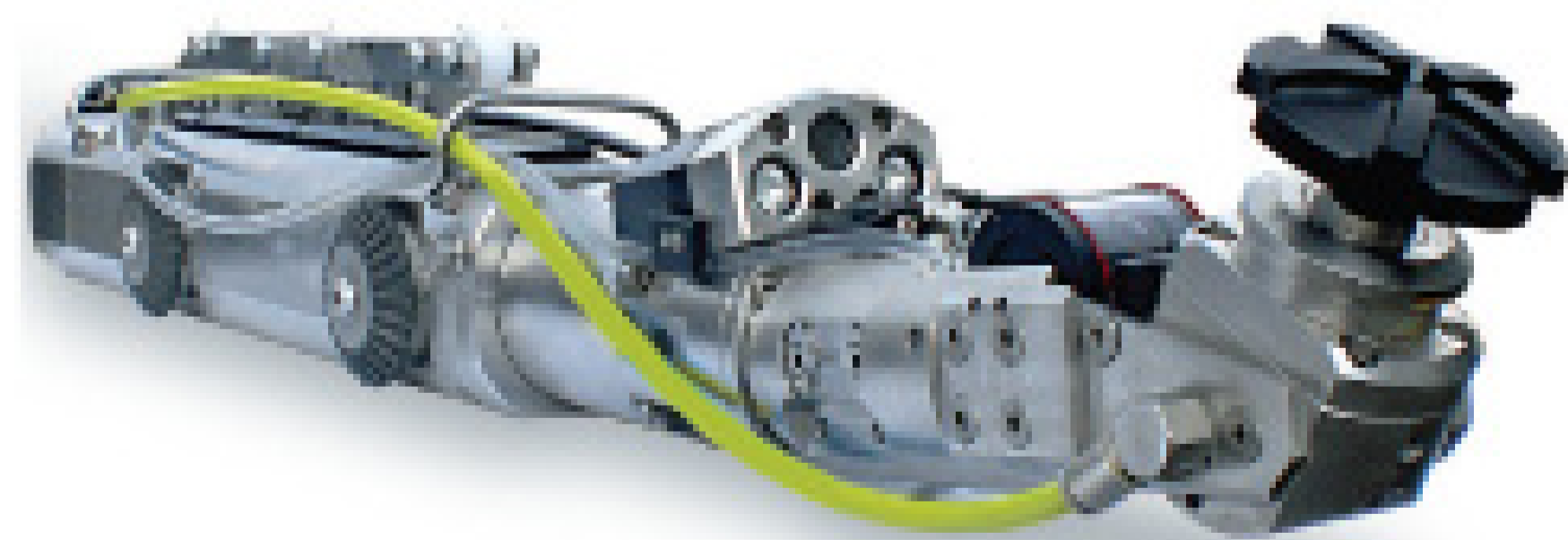

Do sloppy cuts, stalls, and poor visibility hold back your relining crew? Regain productivity with EnviroCut™, the hydro-powered cutter for lines 3.5" and larger. EnviroCut™ mills quickly and cleanly through tough materials. High-pressure water generates 5 times the conventional cutting force, cleans the onboard cameras, and cools the motor and bit. Self-propelled, EnviroCut™ requires no additional CCTV equipment, jetter, or secondary access point.

WinCan V8
Inspection Data Management & Reporting
Factory-Certified Training/Support
Factory-Direct Reseller

Louisville Booth
1130

What It Means To Go Digital

VeriSight™ delivers smart features to make you more efficient, like storage for 45 hours of MPEG4 video, a CF card reader, USB connectivity, tri-frequency SONDE, and a self-leveling head.

Even so, VeriSight's™ rugged design ensures dependable performance. Its welded stainless steel frame, shock absorbers and splash-proof ABS controller withstand everyday punishment, and its Kevlar/epoxy-reinforced push rod maintains 4000-lb break strength.



Long-Range Zoom Cam *Shines Brighter, Sees Twice as Far.*



QuickView™ operators can now see as far as 300' down 18" lines, all while capturing excellent sidewall detail. QuickView™ delivers powerful zoom capability, plus lamp technology that's 65% brighter. Measurement tools and several recording options are available.

Worldwide
Service & Support

Envirosight LLC
SPECIALISTS IN PIPELINE INSPECTION

(866) 936-8476 • (973) 252-6700 • www.envirosight.com



SUBSCRIPTION INFORMATION: A one year (12 issue) subscription to *Cleaner* in the contiguous 48 U.S. states costs \$15.50 (24 issues for \$25; 36 issues for \$35). Subscriptions to Canada or Mexico cost \$27.50 per year (24 issues for \$52). Subscriptions to all other foreign countries cost \$80 per year. Subscribers are guaranteed monthly delivery of the paper. To subscribe, send company name, mailing address, phone number and check or money order (U.S. funds payable to COLE Publishing Inc.) to the address above. MasterCard, VISA and Discover are also accepted. Supply credit card information with your subscription order.

CLASSIFIED ADVERTISING: RATE: \$1 per word, per month. Minimum of 20 words or \$20. All classified advertising must be PAID IN ADVANCE. **DEADLINE:** Classifieds must be received by the first of the month for insertion in the next month's edition. **PHONE-IN ADS ARE NOT ACCEPTED.** Ads may be faxed only when charging to MasterCard, VISA or Discover. Please supply all credit card information with faxed ads. Be sure to include your phone number (with area code) in your ad. Make checks payable to COLE Publishing Inc. and mail with classified ad to the address above. **CLASSIFIED ADVERTISING APPEARS NATIONWIDE AND ON THE INTERNET.** Not responsible for errors beyond first insertion.

DISPLAY ADVERTISING: Call 800-994-7990 and ask for Jim, Kim, Winnie or Phil. Publisher reserves the right to reject advertising which in its opinion is misleading, unfair or incompatible with the character of the publication.

CIRCULATION: Circulation averages 26,185 copies per month. This figure includes both U.S. and international distribution.



**PUMPER & CLEANER
ENVIRONMENTAL EXPO
INTERNATIONAL**

Education Day: Feb. 24, 2010
Exhibits Open: Feb. 25-27, 2010

Kentucky Exposition Center
Louisville, Kentucky

www.pumpershow.com

ARTICLES

46 THE OLD IS NEW AGAIN

By Mary Shafer

On the cover: United Industrial Services in Meriden, Conn., is a diverse business that includes industrial cleaning and vacuum loading of waste. The company has grown with a clear vision combined with hands-on management. Here, Bill Adomo, environmental technician, empties a vacuum truck. (Photography by Johnathon Henninger)

38 STARTING OVER

Farrell Brown invested in video technology and relaunched his business as an inspection and cleaning service. Now he's added pipe bursting and pipe lining.

By Erik Gunn

54 AFTER HOURS: SPIRIT AND DETERMINATION

Despite visual impairment, a Pittsburgh contractor returns to college at age 41, aiming to earn his degree and set an example for his children.

By Christa Kolster

70 RUNNING THE SHOW

The latest versions and tools in business and office productivity software help service businesses stay on top of routing, finance and much more.

By Scottie Dayton

80 TECH PERSPECTIVE: AN OUNCE OF PREVENTION

Like any machine, your computer needs regular maintenance. Here is some basic advice for keeping your system running and protecting it from threats.

By Doug Day

REGULAR FEATURES

10 FROM THE EDITOR: WHAT PERCENT DO YOU USE?

You may never use or need all the computing power that's on your desktop. But chances are you could be using more of that power than you are today.

By Ted J. Rulseh

16 SAFETY FIRST: TOO EXTREME? OR ABOUT TIME?

The National Safety Council proposes a national ban on cell phone use while driving.

By Ted J. Rulseh

24 MONEY MANAGER: FINDING A PARKING PLACE

Your cash reserves don't have to sit idle. With a little planning, you can put these dollars to work earning more for your business.

By Erik Gunn

32 BETTER BUSINESS: PROTECTING YOUR IDEA

If you've ever thought of taking an invention to market, here are some strategies for keeping control of what you have created.

By Fred S. Steingold

62 MONEY MACHINES: GIVING A LIFT

Cranes help technicians move heavy equipment to and from service vans, saving their backs and helping to prevent accidents.

By Ken Wysocky

86 READER PIPELINES: TALKING TECH

Contractors describe how they have adopted technology and innovation to make their businesses more efficient, profitable and satisfying.

By Mary Shafer

92 TOUGH JOB: FRUIT COCKTAIL

A multilayered poly resin liner enables a Pennsylvania food manufacturer to stop leaks and maintain production.

By Scottie Dayton

104 PRODUCT NEWS

Product Spotlight: Compact Crawler Camera System Provides Versatility

By Ken Wysocky

112 INDUSTRY NEWS

COMING IN APRIL

**Special Issue: Drainline TV
Inspection, Location and
Leak Detection**

- Reader Pipelines: Attacking the root cause of stoppages
- Money Manager: Getting a handle on sales taxes
- Profile: Municipal Pipe Tool Co. Inc., Hudson, Iowa
- Profile: Rooter-Man, Charleston, S.C.
- Better Business: The contractor's spouse
- New technologies on display at 2009 Expo

New!

MORE AMMUNITION FROM THE MAKERS OF ROOTX

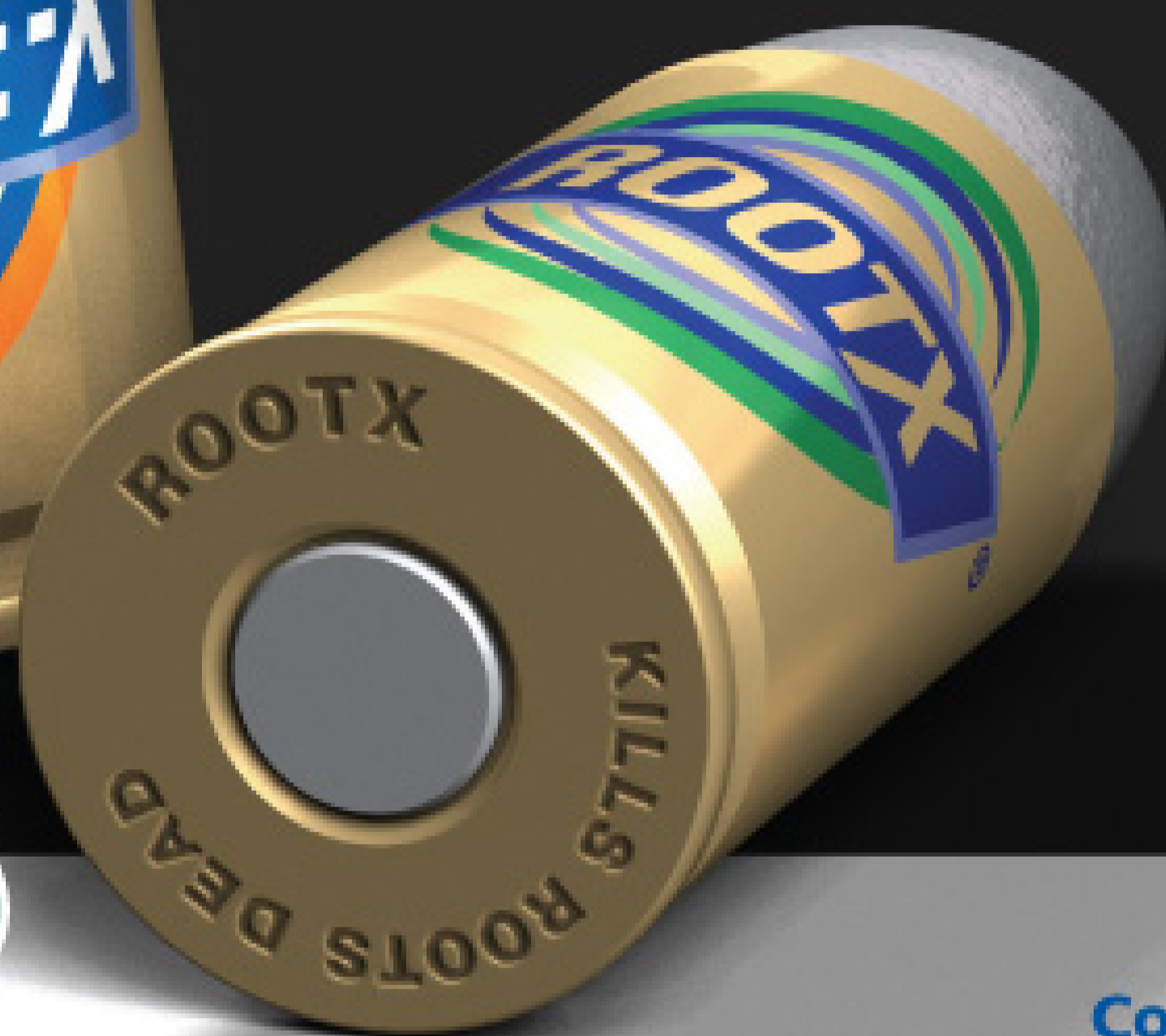

Booth 134

Arm your crews with Grease-X to keep your pipelines FOG-free

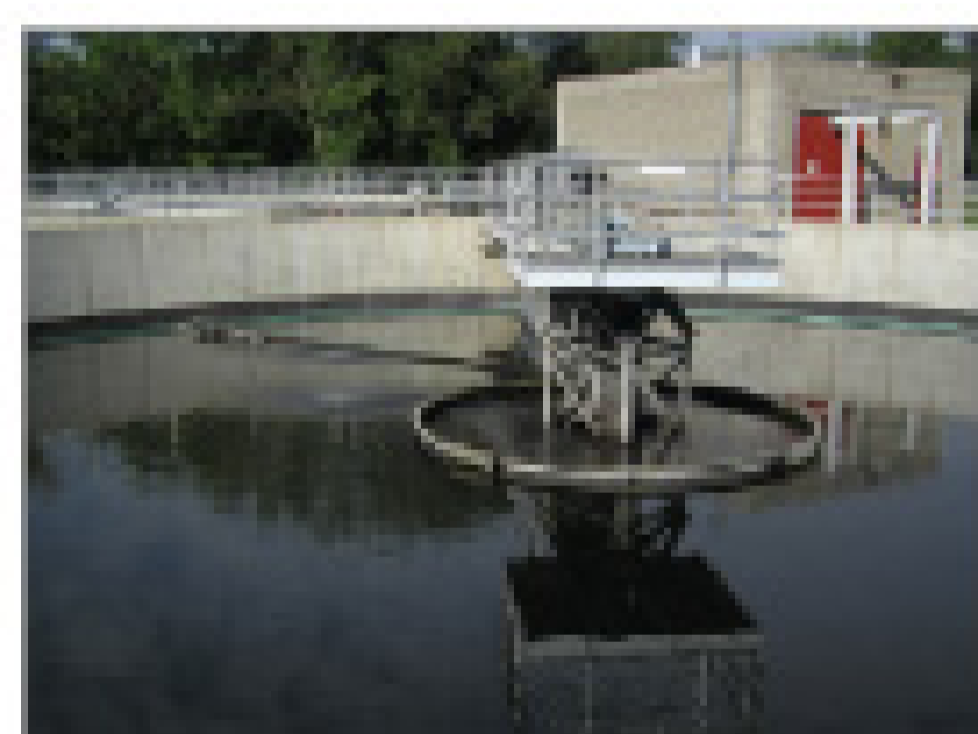

Grease-X reduces the load on your wastewater treatment plants.

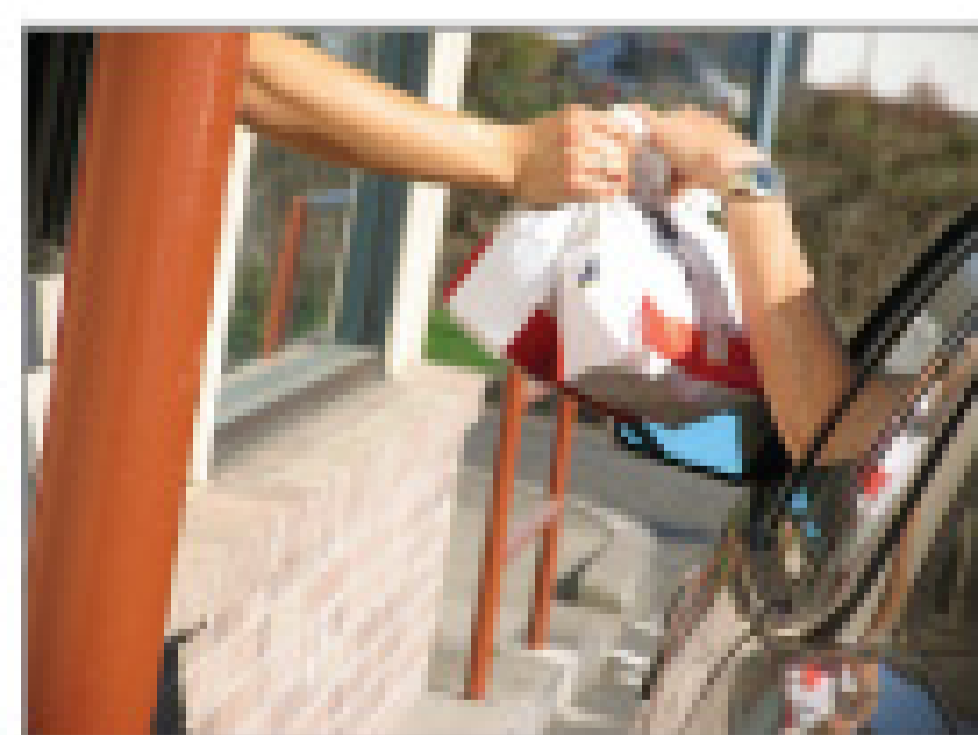

Regular treatments with Grease-X can help prevent FOG buildups—important in problem areas such as near fast-food restaurants.

Introducing Grease-X®—four powerful weapons in the battle against the fats, oils and grease (FOG) that can clog municipal wastewater systems. Grease-X gives you the power to clear FOG-choked pipelines and lift stations, prevent FOG buildup and eliminate pipeline odors using your own crews and equipment.

- **Grease-X Emulsifier**—Non-caustic, non-polluting formula penetrates and softens FOG to clear blocked lift lines.
- **Grease-X Jet**—Fast-acting emulsifier specially formulated for your jetting equipment to open blocked pipelines.
- **Grease-X Biozyme**—Highly concentrated microorganisms break down and digest FOG to keep pipelines clear.
- **Grease-X Biodeodorizer**—Digests odor-causing wastes to eliminate pipeline odors at the source.

Complete sewer system maintenance from a name you trust

You can count on Grease-X to be easy to use and effective because it comes from the makers of RootX®. Together, RootX and Grease-X



It takes just 30 minutes to treat a 400-ft. mainline with RootX.



RootX kills roots on contact and keeps them from coming back.

give you all the ammo you need to keep your wastewater system flowing smoothly.

Both RootX and Grease-X are non-caustic and non-polluting—so they won't harm pipes or wastewater treatment operations. And both are easy to apply. Your crews can treat a 400-foot mainline with RootX in 30 minutes or less. FOG-choked pipelines can be cleared by simply adding Grease-X Jet to normal jetting operations. Plus, Grease-X Biozyme comes in convenient, water-soluble bags, making it easy to keep your pipelines FOG-free.

Don't wait for FOG or roots to back up your sewer system. Arm your crews with RootX and Grease-X.

**Call 800-844-4974 or visit
www.rootx.com to learn more.**

A

A Corp/Rooterman 34



Advanced Infrastructure 68

Al Asher & Sons, Inc. 111

Allan J. Coleman Co. 31, 87

Amerik Engineering 84



Aqua Mole Technologies 22



Aries Industries, Inc. 35

Arthur Products 72

Avanti International 91

B



Bowman Tool Co. & Systems 36

Bright Dyes/Div. of Kingscote 68

C

Cable Center, The 14, 89

Cam Spray 32

Canplas Industries Ltd. 18

Cape Cod Biochemical Co. 22



Central Oklahoma Winnelson ... 108

Chempure Products Corp. 66

Cloverleaf Tool Co. 4, 18



Cobra Technologies 30

Coxreels 78



CUES, Inc. 41

Cyclops Electronics, Inc. 56

D

Doug Meadows Co. LLC 64



Draincables Direct 26



Duracable Manufacturing Co. 76

Dyna-Vac Equipment 68

E



Electric Eel Mfg. 115

Engines Inc. 50



Envirosight, LLC 5

EnviroSpec 107



ENZ USA, Inc. 34

F

Fluid Systems, Inc. 64

Flush Quip 42

ForBest Technologies Corp. 74

Fruitland Tool 76



FS Solutions 45

G

GapVax Incorporated 114

Gardner Denver Waterjetting 109



General Pipe Cleaners 2

Gorlitz Sewer & Drain, Inc. 37

Granite Leasing Co. 53



Guzzler Mfg. Inc. 11

H

Haaker Equipment Co. 30

Hackney Specialized Vehicles 18, 40

Hammelmann Corp. 74

Hannay Reels 42

Hi-Vac Corporation 83

High Pressure Equipment Co. 28

Hotsy Cleaning Systems 19

I

Ingersoll-Rand Hibon 50

Insight Vision 67

J

Jack Doheny Supplies, Inc. 61



Jetstream of Houston 17

J.M. McKinney Co. 82

K



KEG Technologies Inc. 90

Ken's Truck & Equipment 107

Ken-Way Corp. 52

KMH Equipment, Inc. 72

KMT Aqua-Dyne, Inc. 34

L

Lansas Products Mfg. 52

LaPlace Equipment Company ... 60

Lenzyme Inc./Trap-Clear 4

Liberty Financial Group Inc. 88

Lindhorst Workhorse Nozzles ... 44

Link Manufacturing 84

Logiball Inc. 36

M

Masterliner Inc. 109

MAX-LIFE Mfg. 56

MaxLiner 71

Milwaukee Rubber Products 106

Moro USA East, Inc. 56

Mr. Rooter Corp. 57



MyTana Mfg. Company, Inc. 7

N

NESCO, LLC 108



NLB Corp. 51



Northcutt Co./Scooter Video 29



NozzTeq, Inc. 64

Nu Flow Technologies, Inc. 75

P



Pat's Pump & Blower 93



Pearpoint/Radiodetection 58



Perma-Liner Industries, Inc. 13

Petersen Products Co. 109

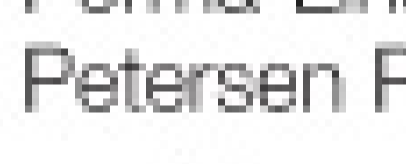

Pipe Genie Manufacturing 69

PipeLogix, Inc. 65

Piranha Hose Products 60

Pittsburgh Wire & Cable 112

Poly-Flow Mfg. LLC 36



PrimeLine Products, Inc. 82

Prototek Corp. 111



Pulsar 2000 27

R



Ratech Electronics Ltd. 55

Rausch Electronics USA, LLC 78

Real-Tite Plugs, Inc. 72

Relining Technologies, LLC 9

RIDGID 33, 43



Ritam Technologies, LP 91



RootX Root Control Corp. 7



RS Technical Services 44

Rush Sales 66

S

Safety Corporation of America ... 42

Sewer Equipment & Supplies ... 74

Sewerin USA LLC 22



Shamrock Pipe Tools, Inc. 28

Soil Surgeon 44

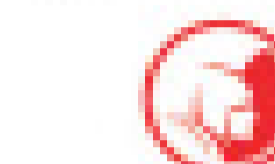

Spartan Tool, LLC 116

Spectrum Environmental 88

Speedway Drain Cleaning Prod. . 77

SPIR STAR, Ltd. 25

SRECO-FLEXIBLE, Inc. 49

Stephen's Technologies 59

StoneAge, Inc. 26, 27

Super Products LLC 79



Superior Signal 10

T



T&T Tools, Inc. 4

Tornado Technologies 90

Triple R Specialty 50

TRY TEK Machine Works, Inc. ... 16

U

US Jetting, LLC 15



USB Sewer Equipment Corp. 106

V

Vac-Con, Inc. 3

Vactor Mfg. 23

Vacuum Truck Rentals 84

Vaporooter 66

Vivax Corp. 60

W

Water Cannon Inc. 85

WaterJet Technology 78

Western Mule Cranes 52

Westmoor Ltd. 58



WinCan America, Inc. 12

WMI Inc. 14

Wolf Creek Co., Inc. 84

World-Tech Industries 63

Woma Corp 111

Classifieds 96-99

Marketplace 100-103

Truck Stop 94-95

**Safeguard your profitability and grow your business...
Diversify.**

800 496 1498 WWW.RELININGTECHNOLOGIES.COM

“We used to install another lining product. We tried Relining Technologies and are so impressed with their customer service, the improvement in our productivity and cost savings, that Relining Technologies is now the only solution we’ll use for our CIPP projects.

-- Anthony Pouliot, General Manager
All Pro Plumbing, Rancho Cucamonga, Calif.

- Rehab 2" to 12" diameter lines
- Applied from the clean out
- Minimal disruption
- Cures in just over 1 hour
- Installed within 1-2 hours
- Custom-built lining rig to fit your needs and budget
- Retrofits of your existing equipment available

FINANCING AVAILABLE

See Us In Louisville! **Booth #5069**

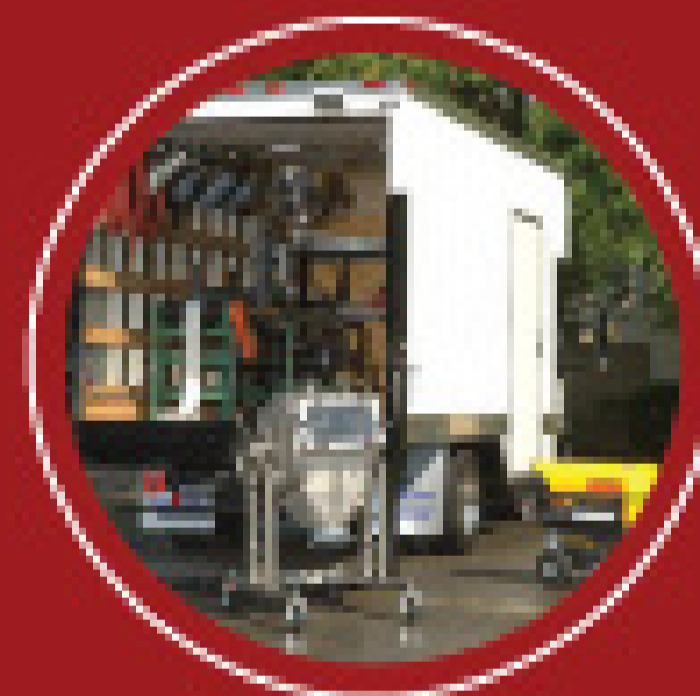

INCREASE YOUR BOTTOM LINE

We are the ideal solution for plumbing contractors looking to expand and diversify their services by offering trenchless repairs—without costly franchise fees or territory restrictions.



PROVEN TECHNOLOGY & TURN-KEY SYSTEMS

With over 10 million feet of lining installed worldwide, our complete turn-key packages help you get started quickly in the fastest growing segment of the contractor market.



SUPPORT FOR SUCCESS

Unlike other vendors that offer just equipment or materials, we provide the tools, sales training, marketing techniques and expert advice needed for achieving unparalleled profitability.



NOT READY YET? SUBCONTRACT!

Tap into the profit potential of CIPP through subcontracting. We offer CIPP outsource services in various geographic locations, call us for details.

What Percent Do You Use?

You may never use or need all the computing power that's on your desktop. But chances are you could be using more of that power than you are today.

Ted J. Rulseh



There's a scene in the movie "Tommy Boy" where the snotty David Spade character tries to teach the thick-headed party boy boss's son about the one-and-a-half-percent carrying charge for merchandise in the Callahan Auto warehouse.

"Let's try an association," the Spade character says. "The average person uses 10 percent of his brain. How much do you use? One-and-a-half percent."

Well, anyway, the common belief that the average person uses just 10 percent of his or her brain is a myth. But odds are most of us use no more than 10 percent of the electronic brain of the computer that sits on our desktops.

Watching the young

I'm reminded of this often when I see my son working on the computer at home. He gets things done so fast my head spins; he seems to know all the shortcuts so that he can do basic things like finding and opening files, organizing pictures, and conducting Internet searches in half to a third the time it takes me.

Of course, I spend most of my time writing (typing) in a word-processing program. It's not as if I need to know multiple software packages to do my job. But I'm pretty sure I don't use even that one program to full advantage. So I wonder, what

about business owners and their office staffs who probably work with software for word processing, spreadsheets, databases, accounting, dispatching, page design and slide creation (for marketing materials), and more.

Software today is to a great extent simple and intuitive – if you know the basic Windows or Apple operating system, you can get reasonably up to speed on most programs without a lot of help. Still, to what extent are your people really proficient versus just getting by on what they've picked up by themselves? What percent of that computing power are they really using?

A revelation

I remember the first company I worked for that used electronic communication extensively – this was in the early 1990s. They offered a couple

surprised at what I could now do with the machine, and how fast.

Today, I know I could benefit from some professional instruction in the software programs I use, and probably from learning a few tools that I don't use now, or use sparingly, but are common currency in business.

How productive?

It makes me wonder: How proficient are most people working in critical office functions for service contracting businesses? A good deal more proficient than I am, no doubt, but how much do they really know and use versus what they could or should?

Have you assessed your people's computer skills lately? Is it possible that if given some formal instruction in the programs they use, they could

To what extent are your people really proficient versus just getting by on what they've picked up by themselves? What percent of that computing power are they really using?

of in-house courses on their e-mail and calendar systems. I was doing all right with both, I was busy with my job and didn't feel as if I had a half-day to spare for training. But I took the course anyway. It opened my eyes.

About once every five or ten minutes I found myself saying silently, "You mean I can do THAT?" Things I learned in that course saved me an absolute ton of time from that point on. And when I got my first home computer (around that same time) I made it a point to take the tutorials on the software that came with it. Again, I was

get their work done faster and more accurately and use new productivity tools they have not been using up to now?

Maybe the modest tuition and a few hours off from work to attend software-specific classes at a local technical college would be a wise investment for your key office team members. Maybe some additional training from your provider of routing or dispatching software would help you take performance up a notch.

I am by no means suggesting that your people aren't up to the task. I am simply asking if your company is really getting the most from your electronic tools. Are your people using just a small percentage of that computer's brain? And if they could use a bigger slice of it, how would that help your business? ■

Superior[®] SMOKE



Classic or Fluid

Only Superior offers Both





**Maximizing your Smoke Testing
results for over 45 Years!**



Booth 6141

www.SuperiorSignal.com

1-800-945-TEST



WE DELIVER MORE THAN JUST A SHINY NEW TRUCK...



We already offer you the most offloading solutions in the industry, and can custom build our vacuum loaders to suit your exact needs. We can help you find financing. And, with our Right Start program, we personally deliver the keys, provide operator and safety training and give you all the information you need to be more productive from the very beginning.

Beyond that we support your new or hard-used old trucks with fast access to genuine Guzzler parts and a toll-free number you can call for application expertise. We also have regional FS Solution service centers that can provide anything from minor repairs and refurbishing to total rebuilds.

And because we want your business to shine as much as a new truck we will pass along customer referrals every chance we get.

For a demo of a shiny new truck*, go to www.guzzler.com today, or call 1-800-627-3171

*Some qualifications apply.

©2008 Federal Signal Corporation. Listed on the NYSE by the symbol FSS.



Infrastructure Inspection Solutions

Direct from competitors specifications,
advertising and comments:



**“Imports/Exports
to WinCan”**

“Synchronize’s with WinCan”

“Runs in WinCan mode”

*Feels
Acts*
“Looks like WinCan”



© WinCan and WinCan America. All rights reserved. WinCan and the WinCan Logo are trademarks of WinCan America, Inc.

Laterals

WCA's unparalleled service and support back **Pipes**
the industry's most popular inspection
collection, analysis, and management software.

Analysis

For information on inexpensive starter
packages to full turnkey solutions to manage
your inspections, checkout our website today!

Manholes

Collect. Analyze. Deliver.

Reporting

505.341.0109

www.wincanamerica.com

It's New!

FREE

information from
advertisers.

See

page 113

for details.

PERMA-LATERAL[™] LINING SYSTEM

- Liner Cures Without External Heat Source
- NSF and IAPMO Certified
- Permanently Stops Root Intrusion
- Seamless/Jointless From Beginning to End

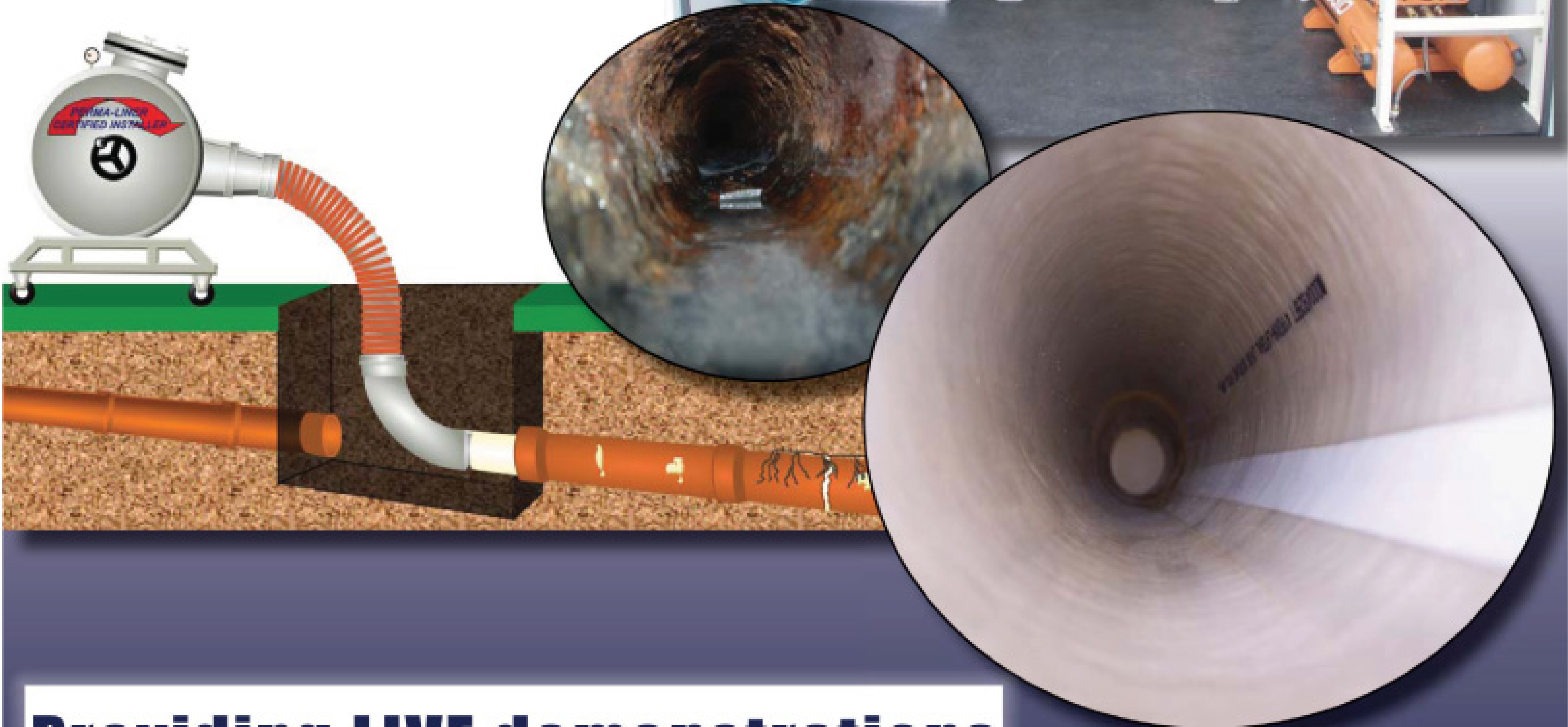

**Providing LIVE demonstrations
at the Pumper-Cleaner Expo**



Visit us at Booth 1186

**PERMA-LINER[™]
INDUSTRIES, INC.**

CELEBRATING OUR 10TH ANNIVERSARY
1999-2009

1-866-336-2568 TOLL FREE

1-727-507-9749 INTERNATIONAL

WWW.PERMA-LINER.COM



Tracked Power Carrier

The WMI TransPorter is specifically for use in the Pumper/Cleaner Industry. You will have unparalleled access to manholes in WETLANDS, WOODED AREAS, NARROW ALLEYS, practically anywhere. The TransPorter is sold with or without the reel and hose.

The unique rubber tracked power carrier has given the Big Roll Sod installation industry years of reliable service. Now you can utilize this remarkable All Terrain Workhorse in the Pumper Cleaner Industry.

The WMI TransPorter will give you an added advantage when you are bidding work in tough to get to locations.

OUTSTANDING MANEUVERABILITY

For more Information or to request a Demonstration or Video, contact our Sales Department:

800-503-0076 • 800-654-1218 • 251-987-1236
28325 Vargo Lane • Elberta, AL 36530
www.wmitsh.com • wmitsh@gulftel.com

THE CABLE CENTER 1-800-257-7209

SUPER SALE

Why wait
for the Show?
Show
specials starting
NOW!

CALL FOR
SPECIAL
PRICING ON
ALL CAMERA
KITS!

FREE
DELIVERY
ON ALL RIDGID
CAMERA
KITS

*** 24 HOUR TURNAROUND ***
MIDWEST'S LARGEST FACTORY
AUTHORIZED REPAIR CENTER FOR
GATORCAM, GEN-EYE
& SEESNAKE

RIDGID Durability Combined
with Digital Technology

- Record videos digitally onto DVD and view on the system or any DVD player.
- High resolution LCD provides superior picture quality, even in sunlight.
- Lightweight at just 25 lbs., for increased portability.
- Water resistant touchpad makes it easy to navigate controls and keeps hands off DVD recorder.



SeeSnake[®] LCD Monitor+DVD

• THE CABLE CENTER • 8318 OLIVE BLVD. • ST. LOUIS, MO 63132 • 314-993-3099 •

US Jetting presents the proven economic stimulus package



4025/600 DUAL REEL TRAILER

Hatz Silent Pack diesel engine

US Jetting 4025 Run-Dry pump

600 gallon, low profile water tanks

Detachable Mini-Jet Hose Reel with 150' of 1/4" hose

Hydraulic power pull-out swivel hose reel with 500ft of 5/8" hose 4000psi @ 25gpm

Gen II Wireless remote control system

Recyclable antifreeze system

Twin full size tool boxes on both sides



CALL 1-800-JETTING
CALL 1-800-538-8464



Training Service/repair Business start-up Loyalty appreciation

WE'RE HERE TO HELP - ALL THE WAY

Too Extreme? Or About Time?

The National Safety Council proposes a national ban on cell phone use while driving

By Ted J. Rulseh

The National Safety Council has not only called on motorists to stop using cell phones and messaging devices while driving – it is urging businesses to enact policies prohibiting those practices, and asking governors and legislators in all 50 states and the District of Columbia to pass laws banning them.

Safety FIRST

In a January news release, NSC president and CEO Janet Froetscher observed, “Studies show that driving while talking on a cell phone is extremely dangerous and puts drivers at a four times greater risk of a crash. Driving drunk is also dangerous and against the law. When our friends have been drinking, we take the car keys away. It’s time to take the cell phone away.”

It would be a mistake to underestimate the NSC’s credibility or effectiveness. The council led the adoption of the “Click It or Ticket” seat belt-use campaign from a one-state pilot project to a 50-state program. “We believe the same kind of culture and behavior change must – and can – be achieved to stop cell phone use while driving,” Froetscher says.

Another distraction

The NSC puts cell phone usage in the larger category of distracted driving. The council observes that driver inattention is a leading cause of traffic crashes. The National Highway Traffic Safety Administration (NHTSA) says driver inattention is responsible for about 80 percent of all collisions.

“Studies show that driving while talking on a cell phone is extremely dangerous and puts drivers at a four times greater risk of a crash. Driving drunk is also dangerous and against the law. When our friends have been drinking, we take the car keys away. It’s time to take the cell phone away.”

**Janet Froetscher
President and CEO
National Safety Council**

And cell phone use, hands-free or not, is a major source of distraction, the NSC argues. The council cites a study from the Harvard Center of Risk Analysis estimating that cell phone use while driving contributes to 6 percent of crashes, which equates to 636,000 crashes, 330,000 injuries, 12,000 serious injuries and 2,600 deaths each year.

The study also put the annual financial toll of cell phone-related crashes at \$43 billion.

Talking on a cell phone may be less distracting than some other activities people may engage in while

driving, but the use of cell phones and texting devices is much more pervasive, making it more dangerous overall, Froetscher states.

The NSC also points to studies from the University of Utah showing that hands-free devices do not make it safe to make cell phone calls while driving. “Another study demonstrates that talking to passengers, as

opposed to talking on a cell phone, actually makes adult drivers safer, because passengers help alert drivers to potential driving risks,” the news release says.

Froetscher adds, “When you’re on a call, even if both hands are on the wheel, your head is in the call, and not on your driving. Unlike the passenger sitting next to you, the person on the other end of the call is oblivious to your driving conditions. The passenger provides another pair of eyes on the road.”

Big use in business

The NSC acknowledges that a significant amount of vehicular cell phone use occurs on the job. “Many businesses have already acknowledged the injuries and costs associated with this behavior by adopting policies that ban cell phone use by employees on the roads,” the council states.

Among NSC member businesses that responded to a survey, 45 percent said they have company policies prohibiting on-road cell phone use. Of those, 85 percent said the policies make no difference in business productivity.

“Anyone with a busy job knows the temptation to multitask and stay in touch with the office while driving,” Froetscher says. “Believe me, I’ve been there. I didn’t realize how much risk I was taking. Most people don’t. Employers understand how dangerous the behavior is and their potential liability. We are asking all businesses to join us by adopting policies banning calling and texting while driving on the job.”

Froetscher has sent letters to all governors and state legislative leaders encouraging them to adopt statewide bans. She acknowledged that achieving and enforcing bans in all states will be a challenge, but she said the NSC has successfully faced similar challenges in the past – notably, seat belt enforcement.

‘There will be a day ...’

“It may be hard for some people to imagine how certain laws, such as those concerning drunk driving, teen driving, seatbelt use and booster seats, can be enforced by observation alone,” Froetscher said. “Smart people in law enforcement get together to address such issues. They develop creative and successful measures to identify violators, such as high-visibility enforcement strategies.”

The NSC will take a three-fold approach to leading change: advocating legislation; educating the public and businesses about the risk of cell phone use while driving; and supplementing distracted driving content in its training of 1.5 million people annually in defensive driving.

“The change we are looking for, to stop cell phone use while driving, won’t happen overnight,” Froetscher says. “There will be a day, however, when we look back and wonder how we could have been so reckless with cell phones and texting devices.”

For a fact sheet, data resources and other information concerning cell phone use while driving, visit the NSC Web site at www.nsc.org. ■

TRY TEK Machine Works, Inc.

FAST DELIVERY
on
replacement parts

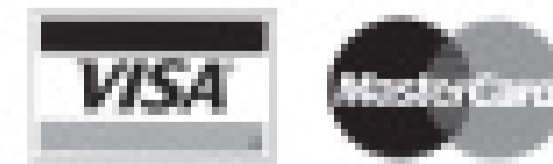

We accept VISA or MasterCard



Contact us for more information:
Phone: 717-428-1477
Fax: 717-428-2865
Email: trytek@trytek.com

250 N. Main St.
Jacobus, PA 17407
USA



**Hundreds
in use!**

www.trytek.com
6" to 15" Tap Cutter

Serving the
industry for
21 years

EASV

to operate • to maintain • to work with



Jetstream waterblasting equipment is easy to operate and easy to maintain. More than that, our units, parts and accessories are backed by knowledgeable, approachable people who understand that our business is your business.

"We always use Jetstream because they have less downtime and they are easier to work on. The people are knowledgeable and helpful. You tell them your problem, and they help you fix it. They'll even drill special nozzles for you."

*Steve Johnson, Division Manager
CCS, Longview, WA*

"They worked with us until the operation was up and running smoothly. With Jetstream's help, we finished what would have been a two-week project in six days."

*Charlie Underwood, Operations Manager
Midwest Waterblasting, Clinton, MI*

It's easy to choose Jetstream.

For more information or a demonstration
call **1-800/231-8192** or visit **www.waterblast.com**.

©2008 Federal Signal Corporation, listed on the NYSE by the symbol FSS.

Jetstream
Subsidiary of Federal Signal Corporation



Pipeline Cleaning & Maintenance Equipment *for*



JETTERS & JET VACS

Penetrators

1/4"-15°	\$24.00
3/8"-15°	\$33.00
1/2"-25°	\$46.00
1/2"-25°LT	\$49.00
3/4"-12°	\$55.00
3/4"-12°LT	\$65.00
1"-12°	\$69.00
1"-12°LT	\$81.00

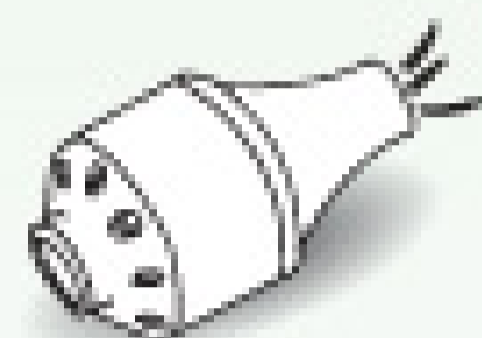

Aluminum Sand

3/4"-24°	\$139.00
1"-17°/24°	\$153.00
1"-24°	\$139.00



Swivel Joints

T-M® Style	
90° or Straight, 6000 psi	
3/4" & 1"	\$175.00
1-1/4"	\$179.00
1-1/2"	\$453.00
2"	\$570.00

Aluminum Grease



3/4" or 1"-17° \$122.00

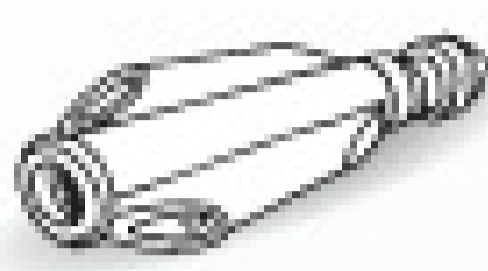

Truder

1" \$345.00



Shark

1" \$480.00
1" Big Shark \$595.00

Stainless Steel Nozzles

1/8"	\$30.00
1/4"	\$33.00
3/8"	\$39.00
1/2"	\$54.00
3/4"	\$59.00
1"	\$105.00

Ball Valves

Dyna Quip®

Style	
3000 psi	
1"	\$227.00
1-1/4"	\$243.00

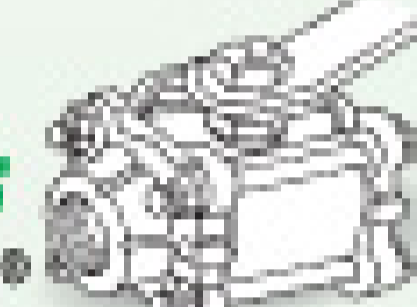

Radial Bullet

3/4"-18° or 35°	\$50.00
3/4"-18°/24°	\$53.00
1"-18° or 30°	\$66.00
1"-15° or 30°	\$68.00
1-1/4"-18 or 35°	\$85.00

Steel Sand

1"-12° \$70.00

NEW Storm/Culvert Floor Cleaner Nozzles

Parker & Piranha Jetter Hose

1/8"-1-1/4"

Saw Blades

4"-18"
NEW Chain Root Cutters
4"-48", All Stainless Steel, No Lubrication

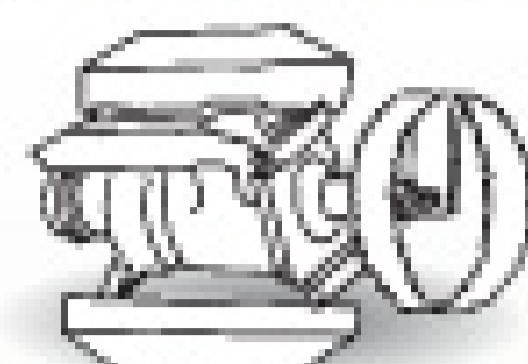

Root Cutter Assemblies

Skid Mounted	
w/flat blades	\$868.00
w/concave blades	\$910.00
w/spiral blades	\$910.00
Donut Mounted	
w/flat blades	\$847.00
w/concave blades	\$889.00
w/spiral blades	\$889.00
Lateral Mounted	
w/flat blades	\$825.00
w/concave blades	\$895.00

Assemblies come with one ea. of 6, 8, 10 and 12" blades, saw blades, hub, skids, etc.

Sewer Hose Guides

TigerTail™ Style	
3" x 36"	\$40.00
2" x 36"	\$34.00

with 24' rope



Clamps

Power Clamps	
8"	\$13.00
3"-6" available	
King Clamps	
8"	\$29.75
4"-6" available	
Bandlock® Clamps	
8"	\$24.00
3"-6" available	
Quick Clamps	
8"	\$26.50
3"-6" available	

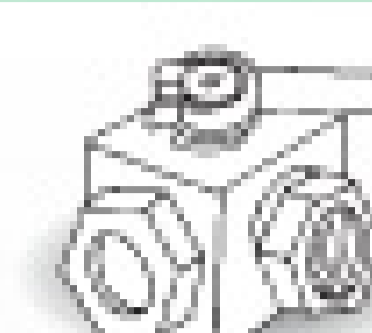

Hycon® Valves

2 & 3-way Ball Valves

5000 psi	
1/2" 2-way	\$65.00
3/4" 2-way	\$89.00
1" 2-way	\$119.00
1-1/4" 2-way	\$226.00
4500 psi	
3/8" 3-way	\$115.00
1/2" 3-way	\$160.00
3/4" 3-way	\$180.00
1" 3-way	\$190.00
1-1/4" 3-way	\$440.00



HD Washdown Gun

25 gpm @ 850 psi
1/2" Inlet \$155.00

Pipe/Sewer Plugs • Hose Reels • Aluminum Intake Tubes
Kanaflex™/Rubber Debris Hose • Full Line Of Warthog Nozzles



Toll Free: 800-365-6583
www.cloverleaftool.com

Full Catalog Online with Prices

SARASOTA, FLORIDA • PHONE: 941-739-0707 • FAX: 941-739-0001

MANY OTHER STYLES, SHAPES & SIZES AVAILABLE

CALL FOR OUR COMPLETE CATALOG WITH PRICES

Endura® Grease Interceptor

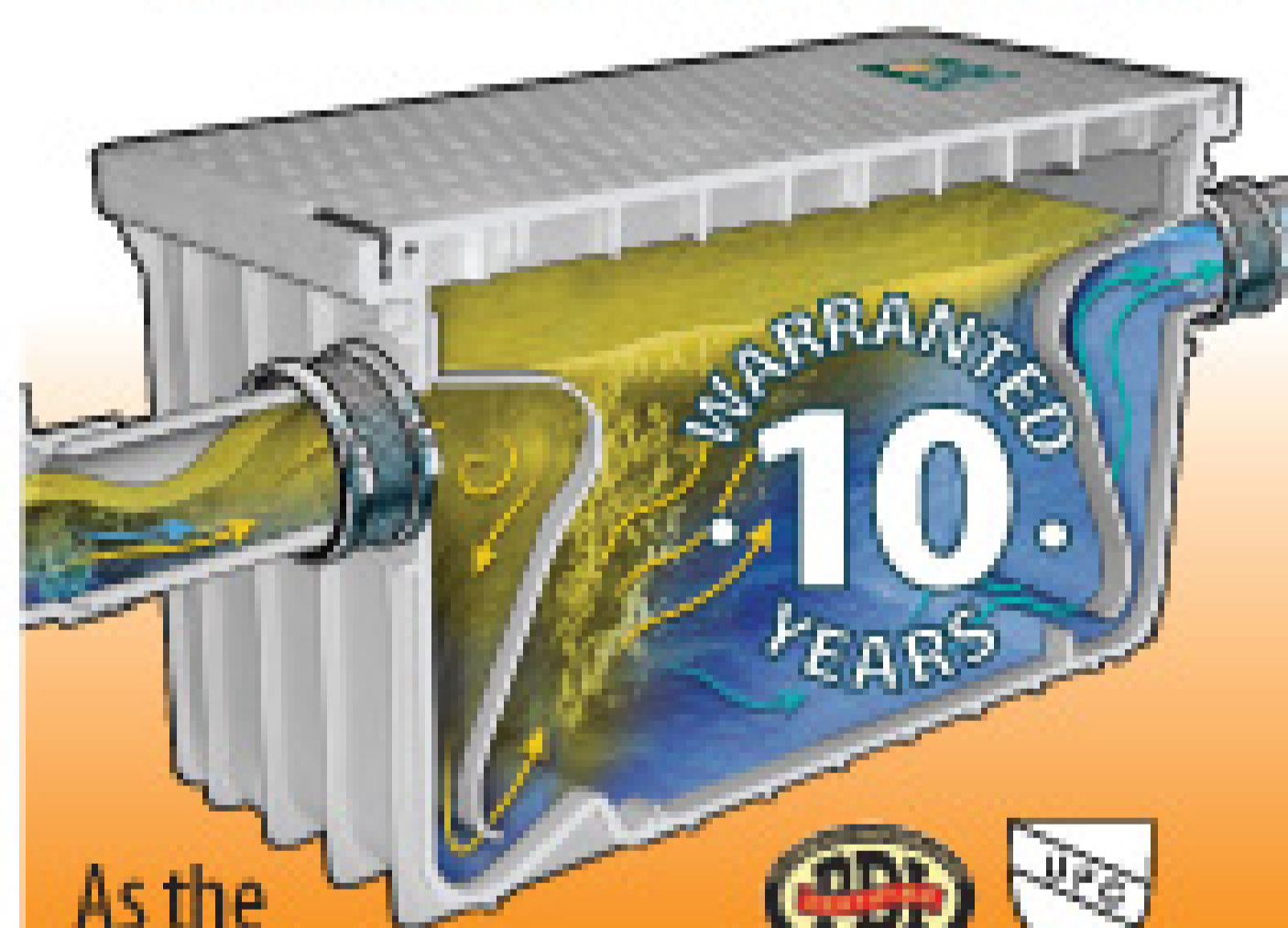

As the only injection molded grease interceptor available, Endura® provides today's installation professional with the best balance of performance and margin opportunity.



Guaranteed to:

1. be where you need it, when you need it!
2. add value to your business
3. be a superior product at a competitive price
4. outlast and outperform

Know when your Endura® interceptor requires cleaning



Endura SENTRY GREASE MONITORING SYSTEM

- Wireless technology between the grease interceptor sensor & wall mounted receiver
- Ensure effective operation against rated capacity
- Maintain record of operation electronically

Visit us at the PUMPER Show Booth #14018
1-888-461-5307 www.endurainterceptor.com



THE P/2000 Supertruck

The Ultimate Service Vehicle



1-800-763-0700 ext. 2317 or visit www.hackneyplumbing.com

Protect your equipment!



IT'S BACK!

hotsy

**\$250 INSTANT
REBATE
& FREE
HOSE REEL
OFFER** (\$250 Value)
★ Limited
Time Offer
A \$500 COMBINED VALUE!

Buy a new Hotsy 795SS Hot-Water Pressure Washer between March 2 and April 30, 2009 and get a **\$250 INSTANT REBATE... plus a FREE EZ HOSE REEL** – that's a \$500 combined value.

The EZ Reel keeps up to 100-ft (3/8") of high-pressure hose safely stored and off the ground.



Model 795SS 3.5 GPM @
2000 PSI, 5HP, Belt Drive

For details, visit
www.Hotsy.com/Rebate3
or call **800-525-1976**

hotsy

Louisville '09
YOUR PLACE. YOUR TIME.

FEBRUARY 25-28, 2009 • KENTUCKY EXPOSITION CENTER, LOUISVILLE KY



WELCOME!

TO THE
PUMPER & CLEANER
ENVIRONMENTAL EXPO INTERNATIONAL

- ▲ **MORE THAN 500 EXHIBITS!**
- ▲ **OVER 60 EDUCATIONAL SEMINARS!**
- ▲ **NETWORK WITH YOUR PEERS!**
- ▲ **WORLD CLASS ENTERTAINMENT!**



In its 29 years, the Expo has helped thousands of professionals like you to build successful businesses and live their dreams. Thanks for making the commitment to visit the Expo. You'll meet the greatest people in the world – and find out just how good your business can become.



Exhibits Open at 9 a.m. on Thursday!
For additional info please visit www.pumpershow.com



SCHEDULE OF EVENTS

Schedule subject to change without notice.

WEDNESDAY February 25, 2009

- Education Day - All Day - No Exhibits
- More than 40 Educational Sessions
- Networking 5-7 p.m.

THURSDAY February 26, 2009

- Certified Onsite Installer Course
- Exhibits Open: 9 a.m. - 5 p.m.
- Educational Seminars: 8 a.m. - 12 p.m.
- Women's Wine, Cheese and Fashion Show
2 p.m - 4 p.m.
- Industry Appreciation Party
5 p.m. - Refreshments Available

FRIDAY February 27, 2009

- Exhibits Open: 9 a.m. - 5 p.m.
- Educational Seminars: 8 a.m. - 12 p.m.

SATURDAY February 28, 2009

- Exhibits Open: 9 a.m. - 3 p.m.
- Saturday Evening Jam
5 p.m. - 38 Special
7 p.m. - Montgomery Gentry
(Show times are approximate)



 **25¢**
Tap Beer!
Thursday Night Only



INTRODUCING...



The Next Generation in Soil Absorption Area Restoration:

SAME DAY BIOREMEDIATION SERVICE!

Cape Cod Biochemical Company, the premier provider of natural septic system solutions since 1976, proudly introduces the culmination of intensive, dedicated laboratory research....

AfterShock Soil Absorption Restorative

AfterShock is a unique blend of laboratory-enhanced, naturally-occurring, primarily aerobic organisms that are type-specific to the various substances that typically clog drain fields and leaching structures. **AfterShock** also contains a proprietary, bacteria-friendly, time-release oxidizing agent that will accelerate the bacterial action of the organisms in the product to restore drainage in most soil absorption areas.

Unlike all other oxidizing products, **AfterShock's** consortium of bacteria and oxidizer can be applied **at the same time**. The oxygen-accelerated bacterial action will quickly digest the solid material that reduces the drain field's capacity to absorb water, effectively restoring drainage through a natural process. The bacteria contained in **AfterShock** are authorized by the USDA, and have been treating septic systems around the world since 1976.

To learn more about this revolutionary approach to restoring drainage, as well as our entire line of products for residential and commercial septic system treatment, grease waste systems, and for bioremediation, please call us toll-free at 1-800-759-2257 to request our product information package. Or log on to www.septiconline.com. There is no cost or obligation, and no obnoxious salesman will call you (a big plus with us).

If you've waited to get involved with bioremediation because the process is so tedious and time-consuming, now is the time to get involved. Do it all in ONE TREATMENT. Please call today. Thank you.

—Rick Howe, President



Visit us in Louisville Booth #3201

GREEN PRODUCTS FOR SEPTIC PROFESSIONALS SINCE 1976

CAPE COD BIOCHEMICAL COMPANY

P.O. Box 990 • Pocasset, MA 02559



1-800-759-CCLS
(1-800-759-2257)

FAX: 508-564-9974 • www.SepticOnline.com



Stethophon® 04



WATER LOSS



Wireless headphone

Now available with Sewerin Digital Radio!

303-424-3611 • www.sewerin.net



CUSTOM DRILLED NOZZLES

SIX PACK KIT™

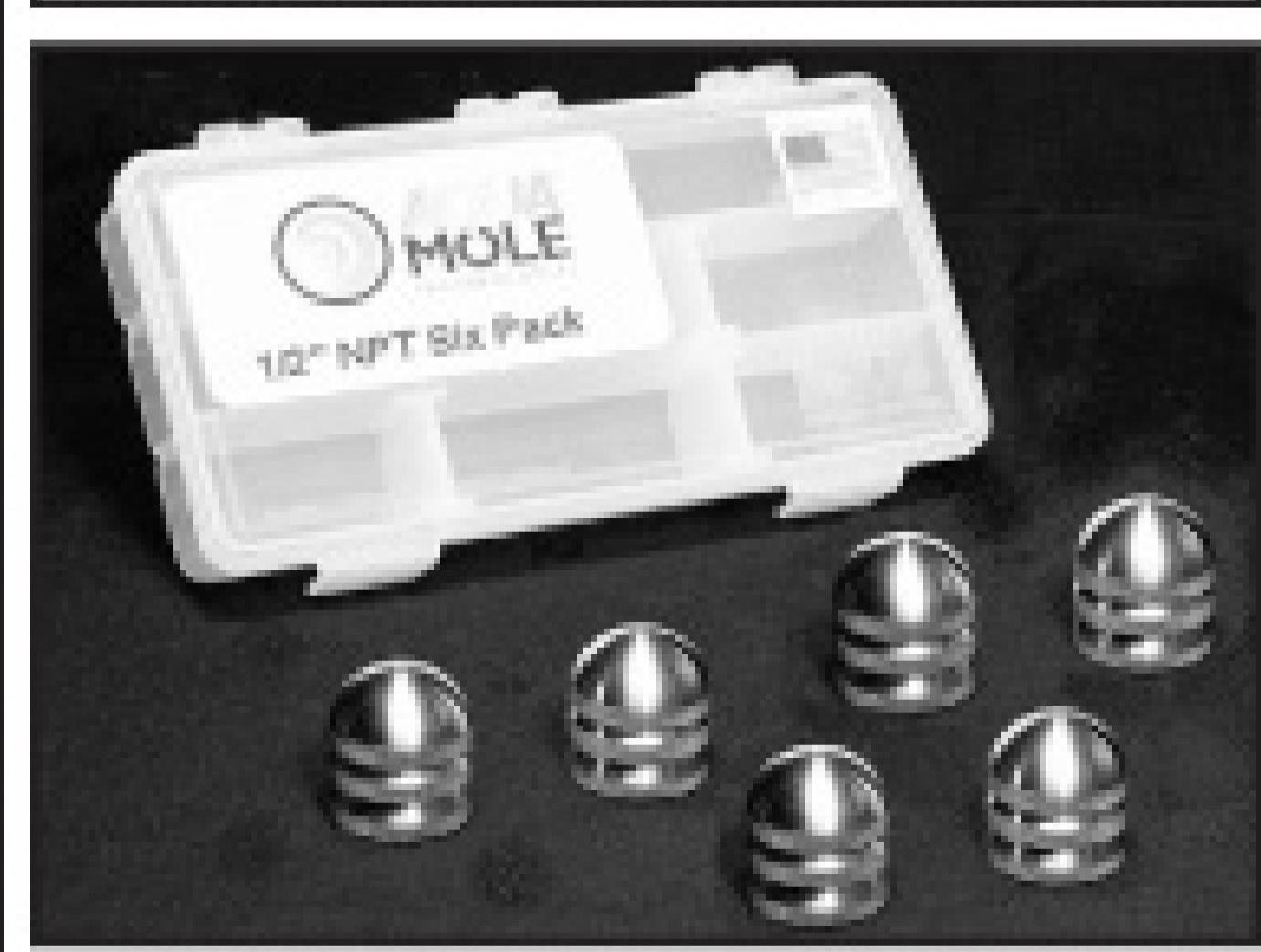

- Each nozzle is **custom drilled** to match your pump's flow and pressure specs for **optimized nozzle performance**.
- Custom drilling means **your choice of spray patterns**.
- Each nozzle is made with **heat treated 416 stainless steel** for superior corrosion and wear resistance, and rated up to 10,000 psi.
- Most orders shipped within **one business day**.
- **100% satisfaction** guarantee.

NPT Size	Price	Savings*
1/8"	\$138	\$32
1/4"	\$149	\$33
3/8"	\$159	\$35
1/2"	\$173	\$39

*Compared to individual prices



CALL TOLL FREE: 877-457-2782
North Royalton, OH 44133 • www.aquamole.com • Fax: 440-237-2987

VACTOR **2100**
Plus



THE STRENGTH TO CLEAN. THE SMARTS TO SAVE.

PROOF THAT VACTOR® 2100 PLUS IS THE SMARTER PARTNER.*

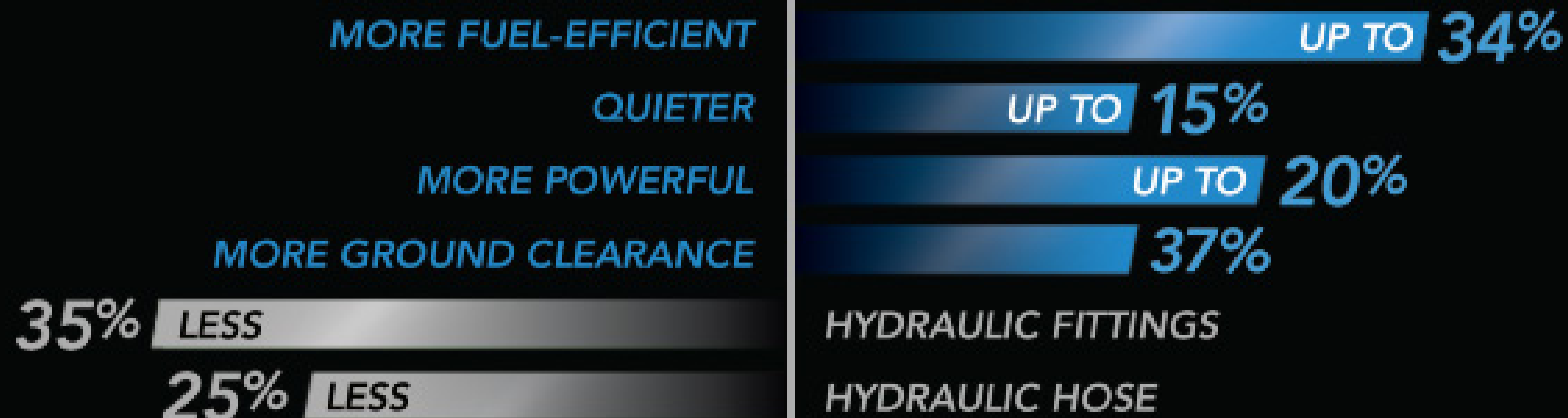

More than just a powerful combination sewer cleaner, the new Vactor 2100 Plus is the all-around smart partner you want working for you. Thanks to exclusive industry-leading innovations, the Vactor 2100 Plus is now quieter, more powerful and more fuel-efficient, saving you up to \$13,500 every year in fuel costs. Add to that a dealer support system that rivals none other and more standard features than ever before, and it's clear that the Vactor 2100 Plus is more than just muscle. It's a smarter, more powerful partner.

To find a Vactor Dealer near you,
call **1-815-672-3171**.

VACTOR®

A Powerful Partner

Visit us at
vactor.com.

©2009 Federal Signal Corporation. Listed in the NYSE by the symbol FSS.

*When compared to Vactor 2100 model. Source: Federal Signal engineering department. Fuel savings assumptions: 3 gallons/hour saved in combination mode (4" orifice at vacuum, 80 gpm @ 2500 psi), 1,500 hours per year at \$3.00/gallon.

Finding a Parking Place

Your cash reserves don't have to sit idle. With a little planning, you can put these dollars to work earning more for your business.

By Erik Gunn

A healthy business generates cash. But what to do with your earnings can be a more challenging question. For too many small business owners, cash not yet paid out for expenses just sits around in a checking account, or perhaps a pass-book savings account.

That's OK if you need quick access to that money. But with just a little bit of inquiry you could do much more with it, and earn a little more money in the process.

So where do you park your money?

The first thing to consider is how soon you need the money you're parking. "People need to know their business and their business cycle," says Jerry Love, a certified public accountant in Abilene, Texas. "Just the fact that you have money today does not mean you're not going to need it 30 days from now or six months from now."

Look at cash flow

So take a close look at your cash flow budget. Your month-to-month bills – payroll, fuel, supplies, insurance – should be fairly predictable. Your monthly gross revenue may be a bit less so. But if you look over the last year, you should be able to estimate how much you need on hand in order to meet your expenses in any given month.

"If you've got to have that money six months from now, you need to know that," says Love, president and CEO of the accounting and consulting firm Davis, Kinard, and Co. Love has another tip: Start very close to home in your search for a cash-management solution. "In most cases, small businesses are best served by going in and sitting down with the banker they already have a relationship with."

Whatever you put cash in, it should be as secure and easy to get at as possible. That means, not the stock market. Because stocks can go down as well as up, they're best investments made with a long time horizon, and even then, you may be better off picking a broad-based mutual fund rather than individual stocks.

"The general consensus is, don't go to the stock market with something you need in less than five years," Love says. The good news is you have other options.

"The general consensus is, don't go to the stock market with something you need in less than five years."

Jerry Love

Consider CDs

Certificates of deposit (CDs) are short- and medium-term savings instruments available at the bank. They pay higher interest than almost any savings or checking account, and like your bank account, they're insured by the federal government.

CDs have one big drawback, though. They're for a set time period, and if you suddenly need the money before they mature, you'll pay a penalty. At the very least, you may be forced to forgo the interest you've earned, and depending on the policies of the institution, you may have to pay an additional fee.

Still, for medium-term savings, they're a safe haven. You could even view the penalties as an advantage, if you need that kind of a roadblock to keep you from spending otherwise ready cash impulsively.

You can also make your money a little more accessible by purchasing several small CDs that expire at different times, instead of buying one big CD. "Laddering" CDs in this way makes at least some of the money available at almost any time.

Money market checking

A money-market checking account doesn't pay as much as a CD, but it offers an important advantage: The money is immediately accessible. Money market accounts usually carry minimum deposit requirements: If your account falls below the minimum, you get no interest and may be charged a maintenance fee.

Bond funds

Various kinds of bond funds may be an option if they don't tie up your money for longer than you can realistically afford. "If you've been through a full business cycle and you're confident that you've got so much money or more available to you, then you might look into moving into a bond instrument that would give you a bit higher return than a CD rate," says Love.

Erik Gunn is a magazine writer and editor in Racine, Wis., where he operates Great Lakes Editorial Services, consulting for businesses, nonprofits and individuals. Readers may direct inquiries to him by contacting this publication at 800/257-7222 or e-mailing editor@cleaner.com.



Use caution, however: Bonds are safer than stocks, but they aren't risk-free. Pick a bad one and you could wind up losing money. Also, like CDs, they'll lock up your money for a time.

If, after consulting with your financial adviser, you decide bonds make sense, you have one other question: taxable, or tax-free? Various kinds of municipal or government bonds pay less interest than private-sector bonds, but their tax-free earnings can actually make some of those funds a better deal.

Sweep accounts

Banks offer these accounts to people with substantial amounts of cash. A sweep account is one that lets the bank put your money overnight into a money-market fund. Essentially the bank is borrowing money for very short-term investments, using the cash to oil the wheels of commerce. You get the money back, along with an interest payment, by the time business opens the next day.

Ask questions

Web sites such as www.money-rates.com can give you ready access to information about the best deals on these and other accounts nationwide, but it's important to be sure that you're doing business with an institution that allows you easy access – to its personnel and to your money.

"You're still going to need to move money back and forth," Love points out. "You need to make sure that you know something about them." You'll also need to make sure no single bank account you carry exceeds the federal limit for deposit insurance.

Never make a change in your current banking and investing arrangements without first understanding your alternatives and the risks and benefits of the change you plan to make. As Love notes, your existing banker is a good place to start.

Indeed, if you move money to some other bank chasing a higher rate, you may find your current bank – where you may hold a line of credit or have a good loan history – will hike your lending rate in the future, because you're no longer a favored customer.

But don't let those warnings turn you away from exploring all possible alternatives. After all, you work hard in your business. Your cash should, too. ■

SPIR STAR®



Tough Times Demand Tough Hoses

Count on our cost effective solutions

Blast-Pro®

- Allows faster cleaning rates and reduces job time.
- Increases operating pressure at the nozzle for improved efficiency.

Duralife® Flex

- Lasts 40% longer than standard flex lances.
- Decreases downtime and replacement costs.

Silver Mongoose®

- Built for extreme service and rough handling.
- Super urethane cover lasts three times longer than standard rubber hose.

Maximus®

- Larger ID increases flow and decreases costly pressure drop.
- Reduces wear and fatigue on your entire pump system.

Proven products that keep your profits up and costs down!

10002 Sam Houston Center Drive • Houston, TX 77064

Toll Free: (800) 890-7827 • Fax: (888) 893-1255 • Phone: (281) 664-7800 • Fax: (281) 664-7850

www.spirstar.com

© 2009 SPIR STAR

Come see us at the Show!

New Tools, New Booth, New Catalog

If you are interested in the latest advancements in high pressure waterblast tools come see StoneAge.

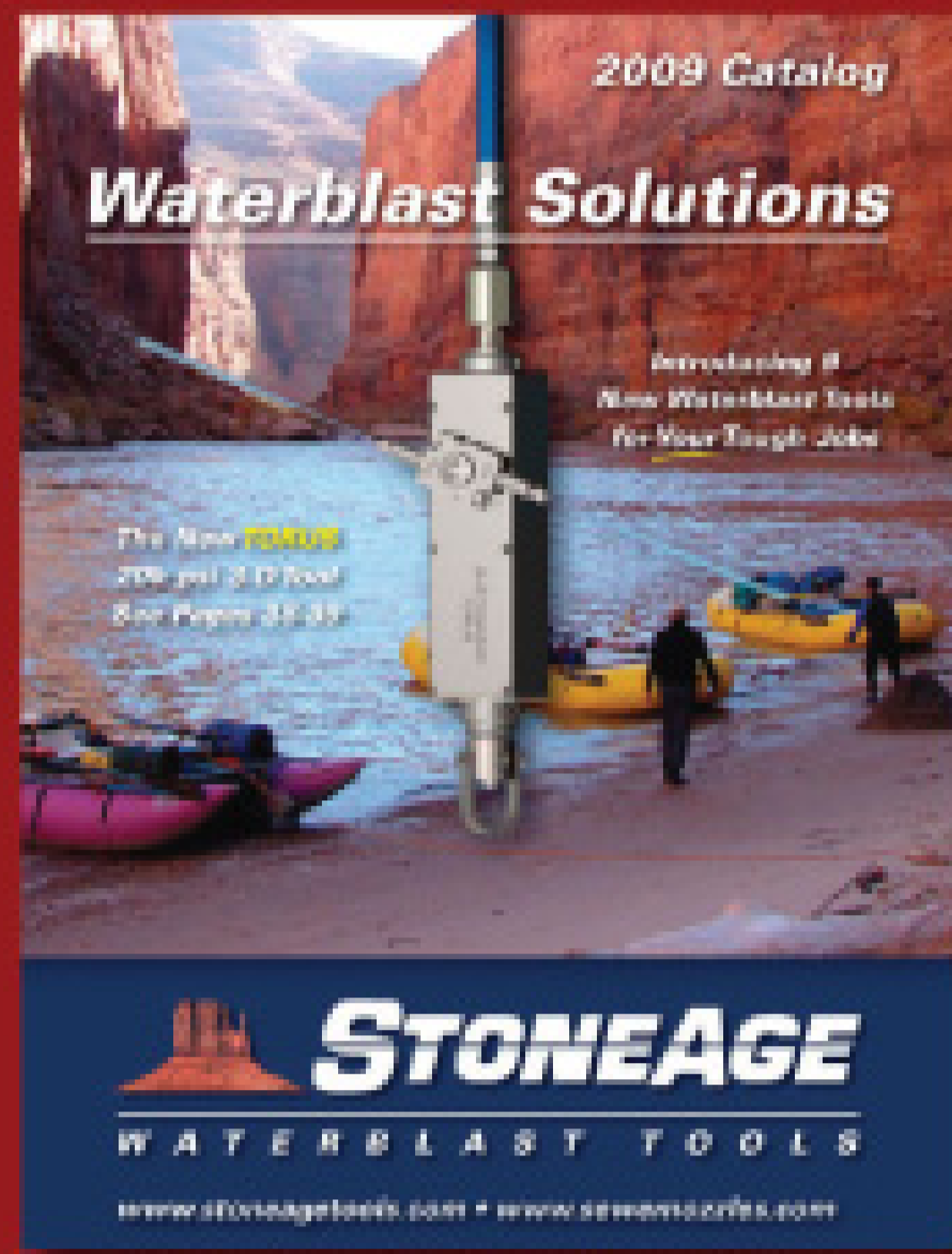

2009 StoneAge catalog with 9 New Tools!

- **New Tools** - We will have a booth full of new tools for cleaning tanks, tubes, pipes, surface preparation, providing both safety and automation.
- **New Booth** - We have moved our booth location to #4133, it's over 2 times larger than last year!
- **New Catalog** - Our new 2009 catalog is full of our latest advancements. Come by and get your new copy.
- **New Website** - Our 2009 catalog becomes our web site, so if you can't make the show, see us on the web.

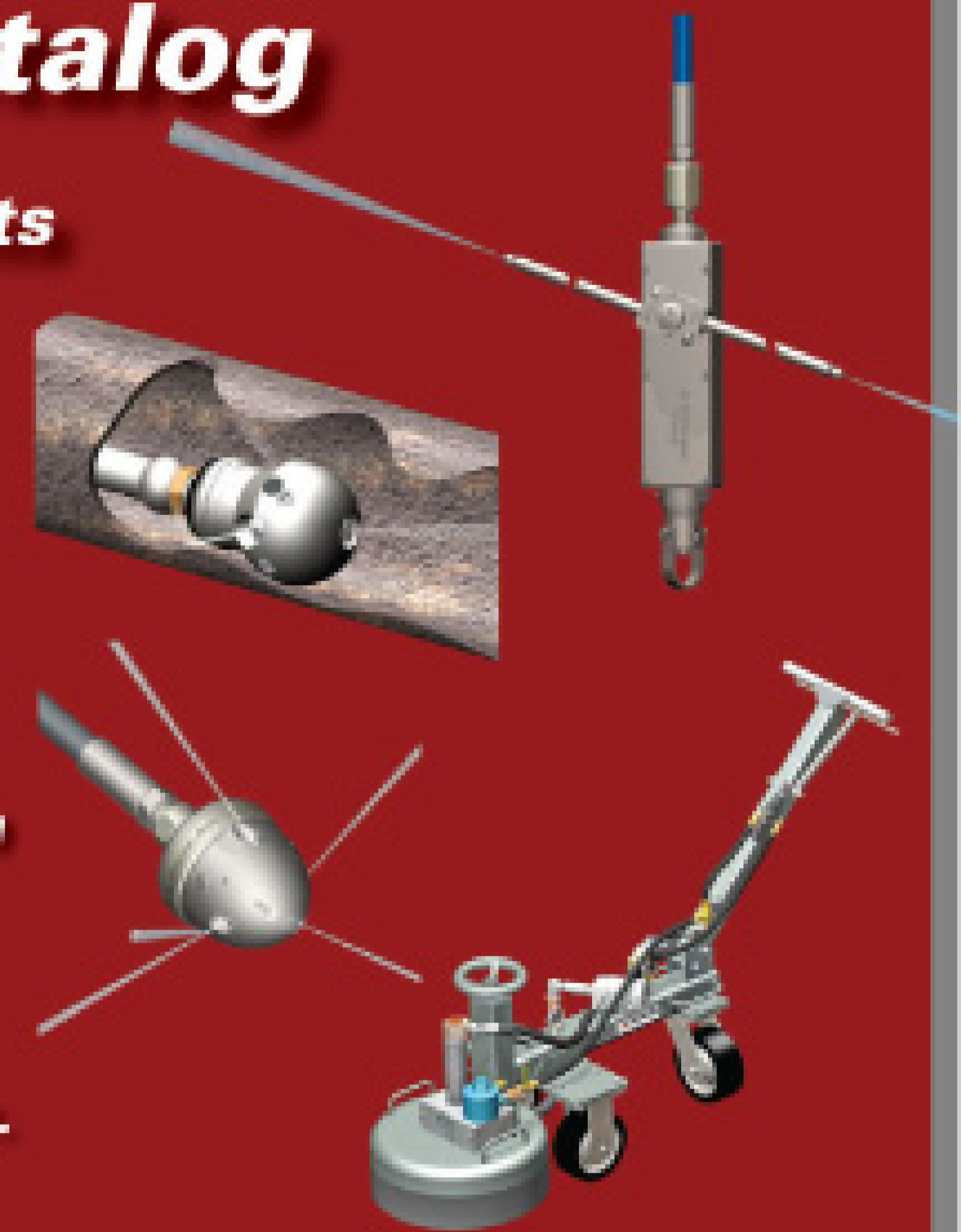

Here is just a sample of some of the new tools!

www.stoneagetools.com

P. (866) 795-1586 F. (970) 259-2868

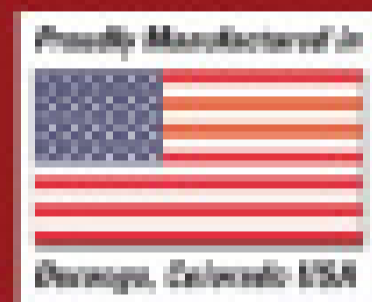

EXPO SHOW SALE 15%* off

CABLES, TOOLS & ACCESSORIES

Now Available!
Video Inspection Cameras!
Stop by booth #4118



Call or visit us at the show
1.800.421.4580
www.draincables.com



Sale effective Jan. 19th - March 27th, 2009



* Some exclusions apply



NEW!
Now manufacturing!
.55 & .66
Double Wound Cables
Available in 25' or 50' lengths

4370 Moline Martin Road
Millbury, OH 43447
PH: 419.838.6090
FAX: 419.838.6071

a division of Service Spring Corp.
DRAINCABLES
direct

WARTHOG™ Solutions

For Demanding & Abrasive Sewer Line Cleaning

NEW

For everyone from trailer jettors to pumper trucks & municipalities

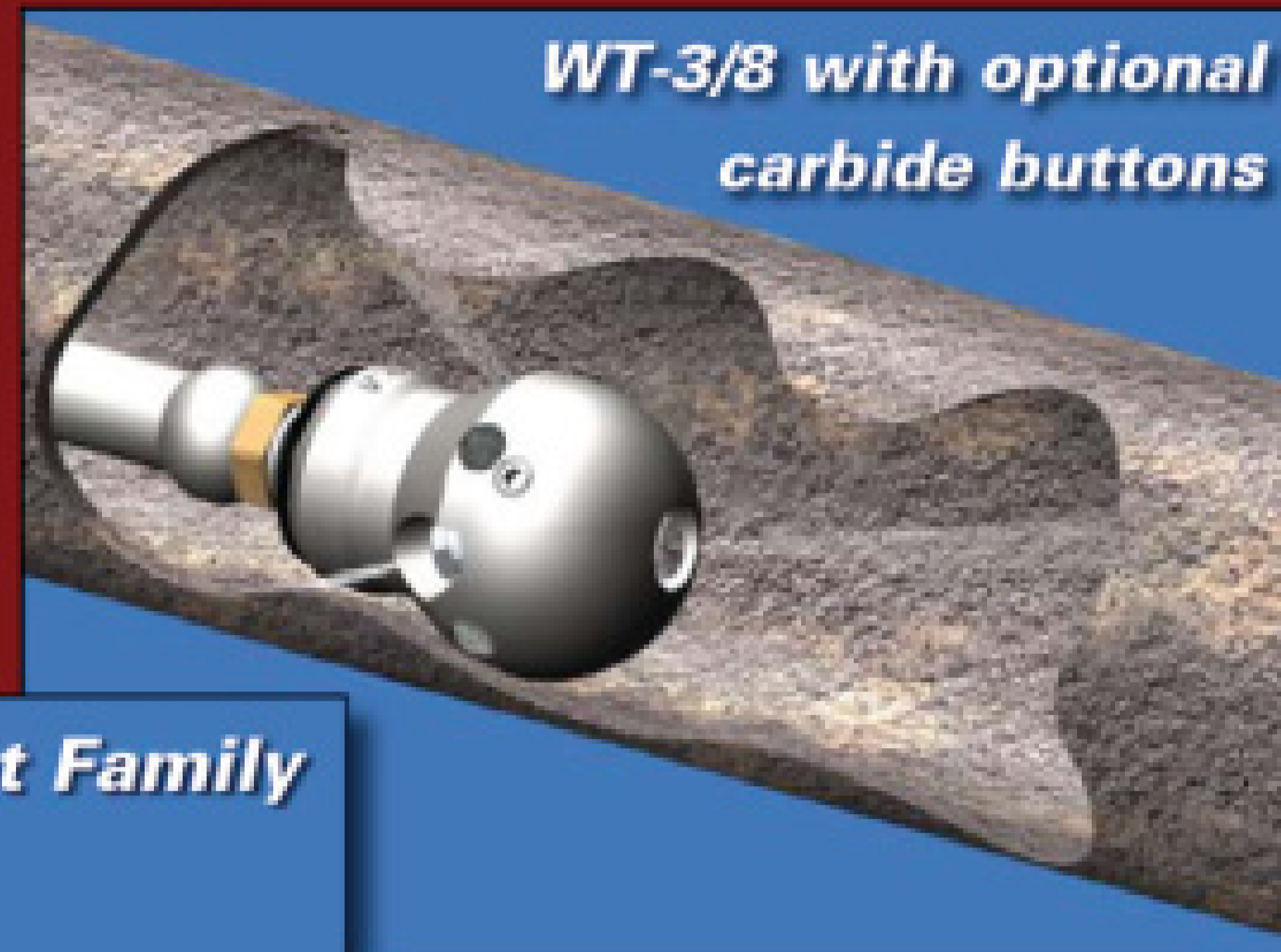

WT-3/8 with optional carbide buttons

WT-3/8 Warthog™ now available with carbide buttons

Pipes made of cast iron or those with sand or silt can act as abrasive agents that aggressively wear out tools. StoneAge has added carbide buttons to the WT-3/8 to extend the life of the tool by at least 3 times.

The WARTHOG™ Sewerjet Family



WD 1-1/4
6"-36"
Pipes

WG-1
6"-36"
Pipes

WH-3/4, 1/2
6"-18"
Pipes

WS-1/2
4"-8"
Pipes

WT-3/8
3"-6"
Pipes

Visit www.sewernozzles.com for a dealer near you!



Pulsar 2000 Line Tracer

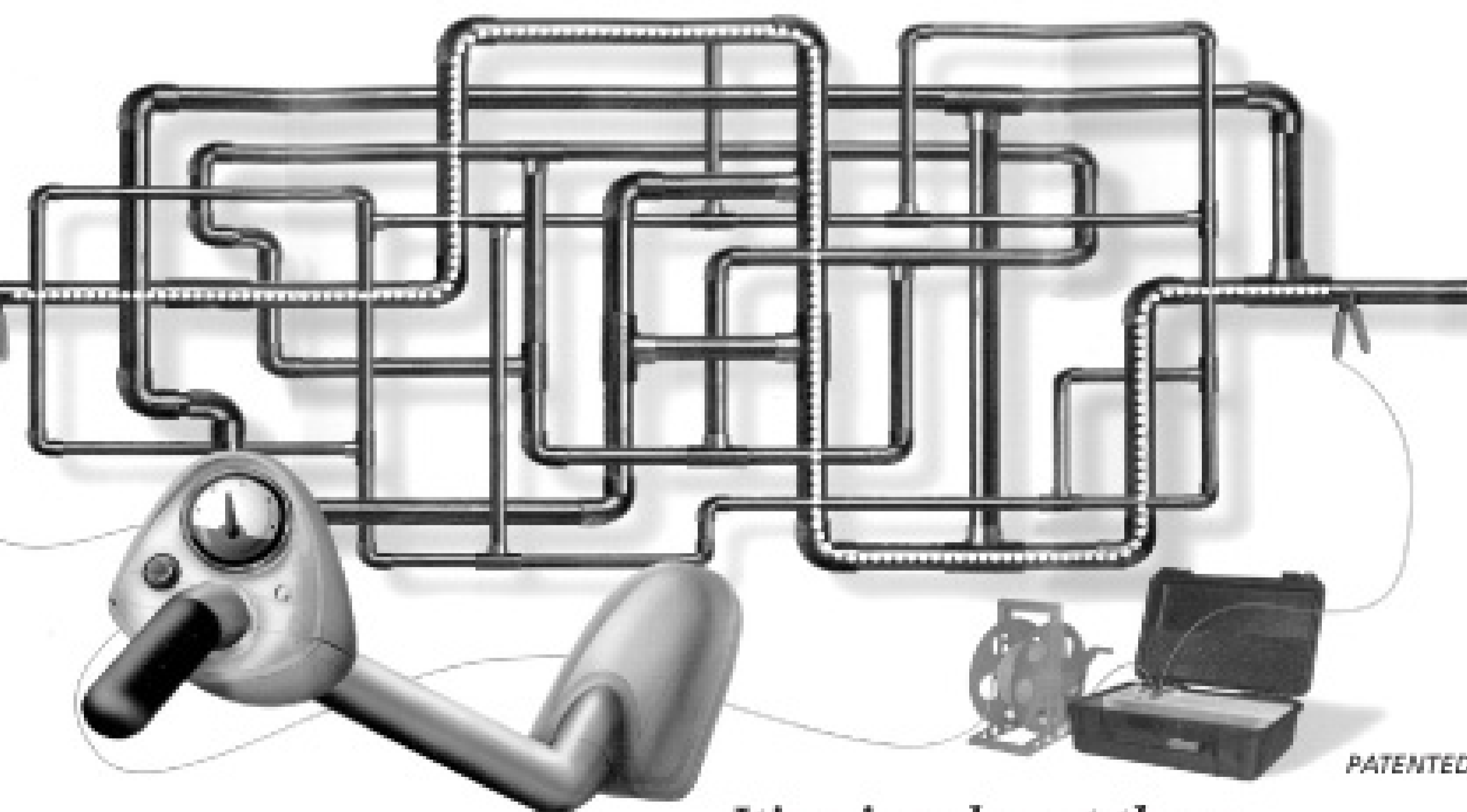

It's a jungle out there.

Locate Lines • Locate Water Leaks • Training Video

www.Pulsar2000.com

DISTRIBUTORS WANTED



The Pulsar 2000 line tracer is designed primarily to locate metallic pipes. The Pulsar 2000 is a directional line tracer. Connect the Pulsar's powerful and unique transmitter to your target pipe and locate only that pipe. Locating can be accomplished under floors, in walls and in ceilings. The Pulsar 2000 does not require grounding.

Leak detection personnel... The Pulsar 2000 is a **must have** locator. Now you can quickly identify the pipe location, thereby reducing the search area of the leak.

100% satisfaction guarantee... We are so sure that you will see the time saving benefit of the Pulsar 2000, we will let you return it for a full refund if you are not satisfied. If you want to learn more about the Pulsar 2000 and our leak locating equipment, please call **1-888-752-5463** or e-mail jsm11@aol.com for a **free** demonstration video or CD and references of satisfied customers.

We have been using the Pulsar 2000 along with the XL2 fluid detector and Geophones since January 1989 in our leak locating business. Our leak locates are **accurate 95% of the time**, but I can honestly say, the line we trace is always there. Our equipment is user-friendly and requires very little training, as you will see on the video. Purchase the Pulsar 2000 line tracer, XL2 fluid detector and Geophones, and start locating leaks immediately.

A Boost in Productivity.

Free with every nozzle.

For over 25 years Shamrock Pipe Tools has been helping sewer service pros achieve unparalleled results with high precision tools for every type of pipe cleaning project.

Call or visit us online today to learn how working with our tools can impact your sewer cleaning performance and productivity.

SHAMROCK
PIPE TOOLS, INC.®

800.633.7696 | www.shamrocktools.com

Made In the USA



See Us in Louisville #2203

EXCELLENCE IS REFLECTED IN EVERYTHING WE MAKE.™

Count on HiP for Reliable High Pressure Flow Control

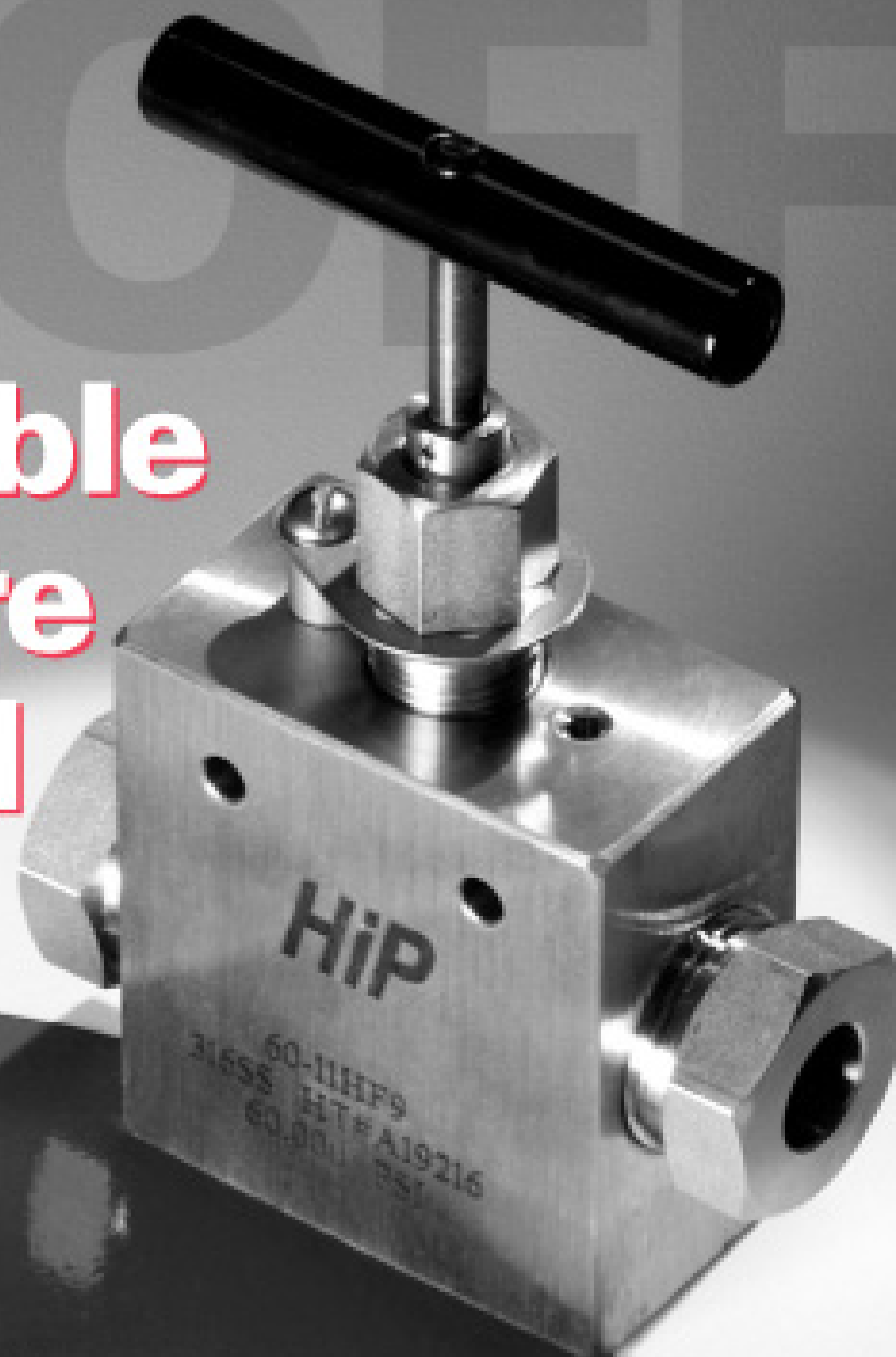

High Pressure Valves

Six valve patterns in six pressure classes (up to 150,000 psi) for reliable and flexible shut-off

High Pressure Fittings

Complete range of elbows, tees and crosses for all pressure classes and tubing connections

Air Operated Valves

Five lines of air operators accommodate remote operation of high pressure valves up to 100,000 psi

High Pressure Tubing

Tubing is cold drawn, seamless 316 S/S and supplied in 1/8 hard conditioned (not annealed)

Specialty Valves

Ball, high temperature, micro-metering, relief, pipe connection and male bottom connection valves. Special materials available.

**HiP... Our Name
is High Pressure**

Call 800-289-7447 or visit
www.highpressure.com

"Simplify your life!"

SCOOTERS ARE EASY TO USE,
TOUGH AND DEPENDABLE.
DON'T LEAVE THE SHOP WITHOUT ONE.

Scooter
Sez!!!

10% OFF

After Christmas
Clearance
Sale

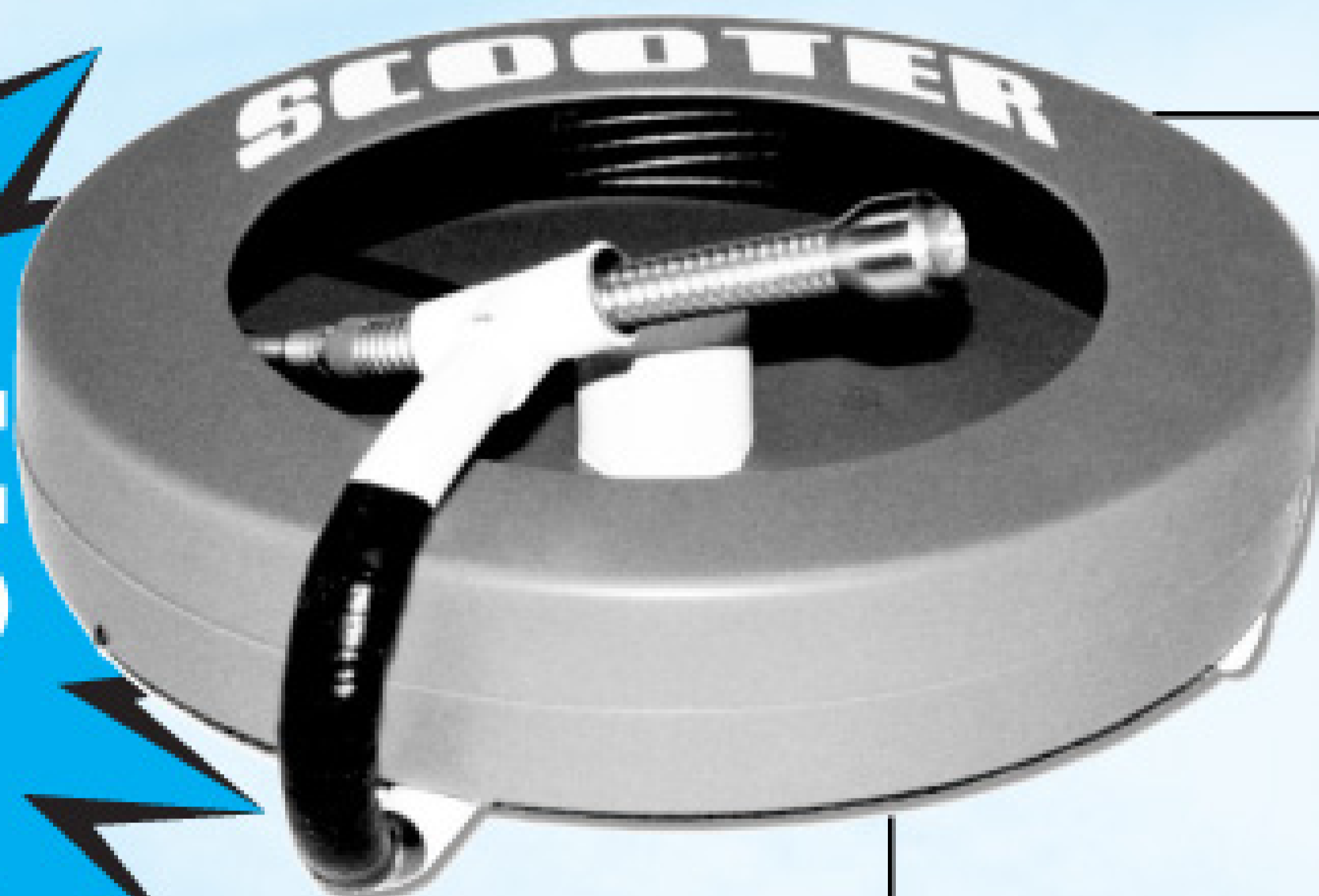

COLOR

Video Inspection Systems

Complete from **\$4,595**

Black & White
Video Inspection Systems

Complete from **\$3,295**

FEATURES:

- Diffuser lighting
- Flexrite gooseneck
- Quick change cameras
- Ultra tough pushrod
- Lightweight/compact
- Solid state lights
- One Year warranty

OPTIONS:

- Image inverters
- Voice over
- VCR/monitors
- Locators
- Carrying cases

Prototek
Line Locating Tools - We
Feature the Finest!



Now
with
DVD!

The New Attaché Monitor
Lightweight & Compact!

VCR combo can be ordered with any Scooter system!



SCOOTER

VIDEO
INSPECTION SYSTEMS

20843 Santa Lucia • Tehachapi, CA 93561 • Fax: 661.822.8917

800.772.6165 www.tvinspection.com

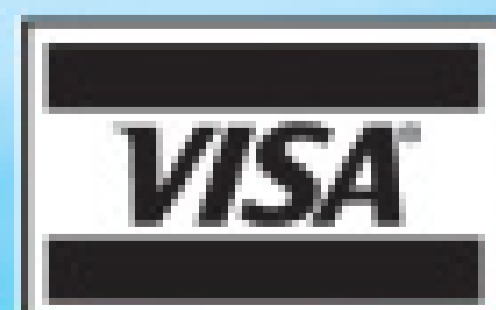

COME SEE WHAT'S NEW

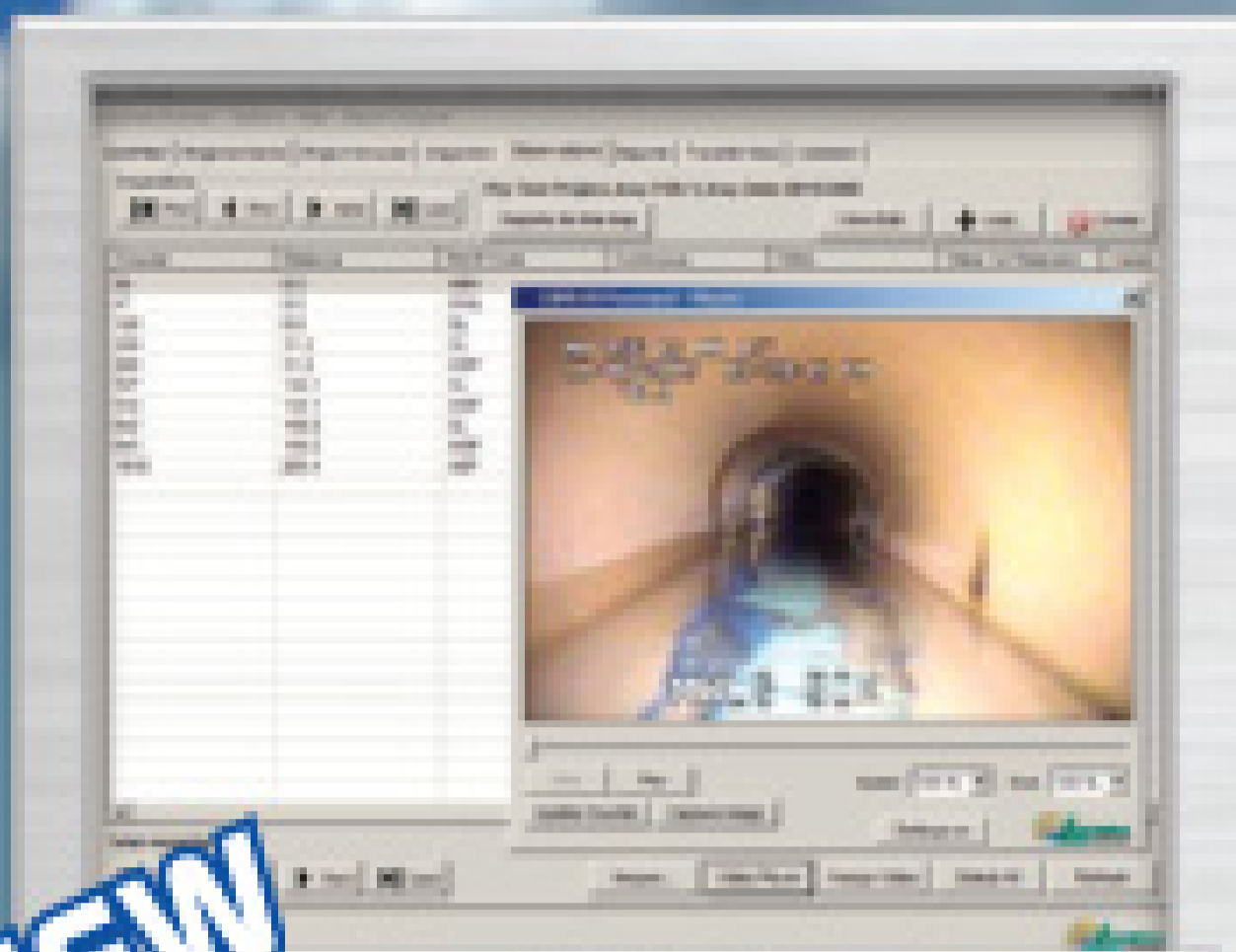

NEW

CIMS v9
Data Management Program

CIMS v9:

The next step in the evolution of our data management software built on a SQL database. This program keeps all of the features our CIMS™ users know and love while adding powerful new tools such as customizable reports and more robust sort, filter, and search functions.

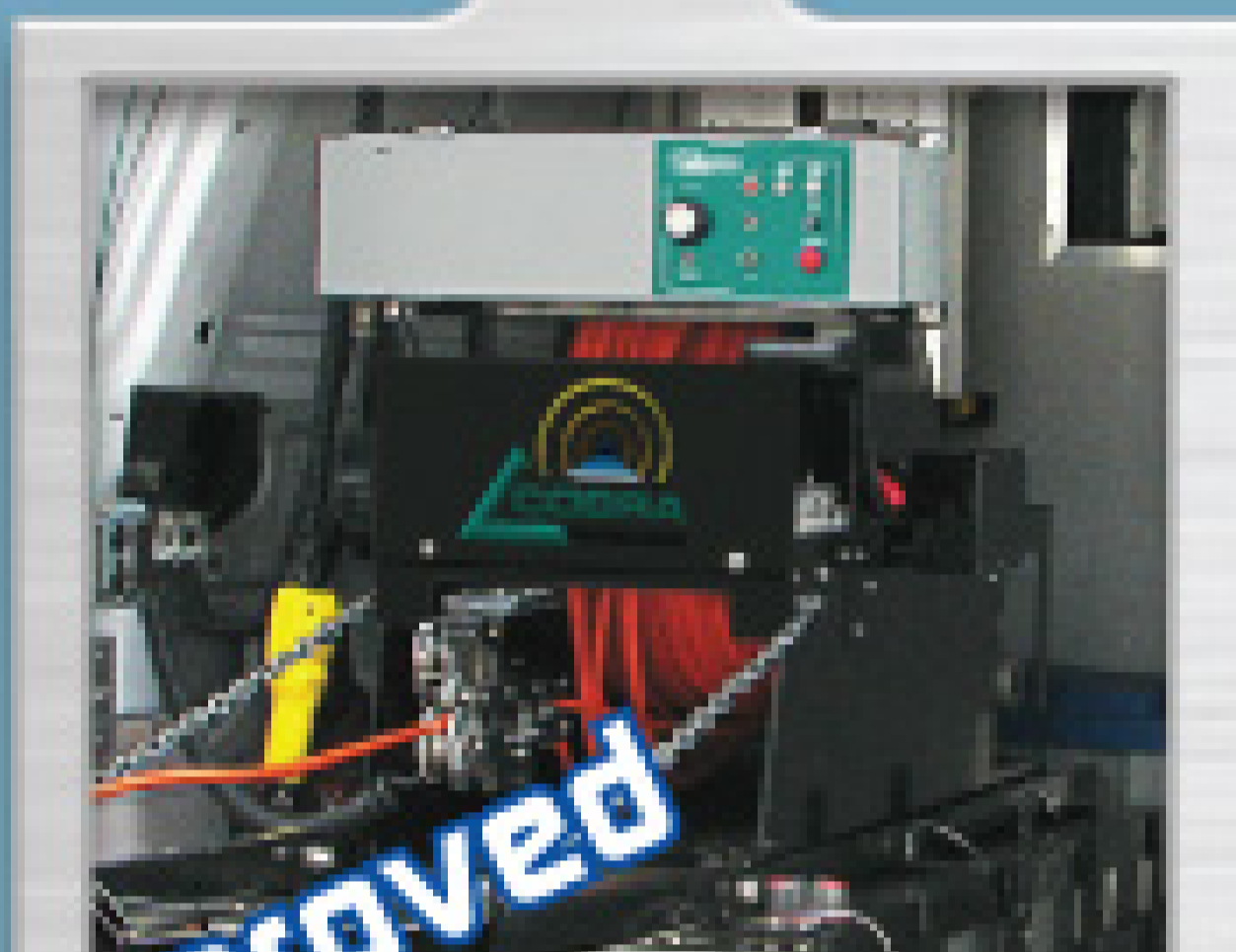

Improved

Main Line Reel

Main Line Reel:

We've added a positive-engagement electro-mechanical clutch which eliminates any possibility of slippage. It also provides automatic cable feeding taking some of the load off the crawler.

Come see our exciting new and improved products at the Pumper Cleaner Show.



NEW

Portable Inspection System

Portable System:

Our new portable system, now in a much smaller package, has a sunlight readable touch screen and all the features of our truck mounted system.

Steerable Crawler:

We've completely redesigned the drive system to make it more powerful.



Improved

Steerable Crawler & Remote Gantry

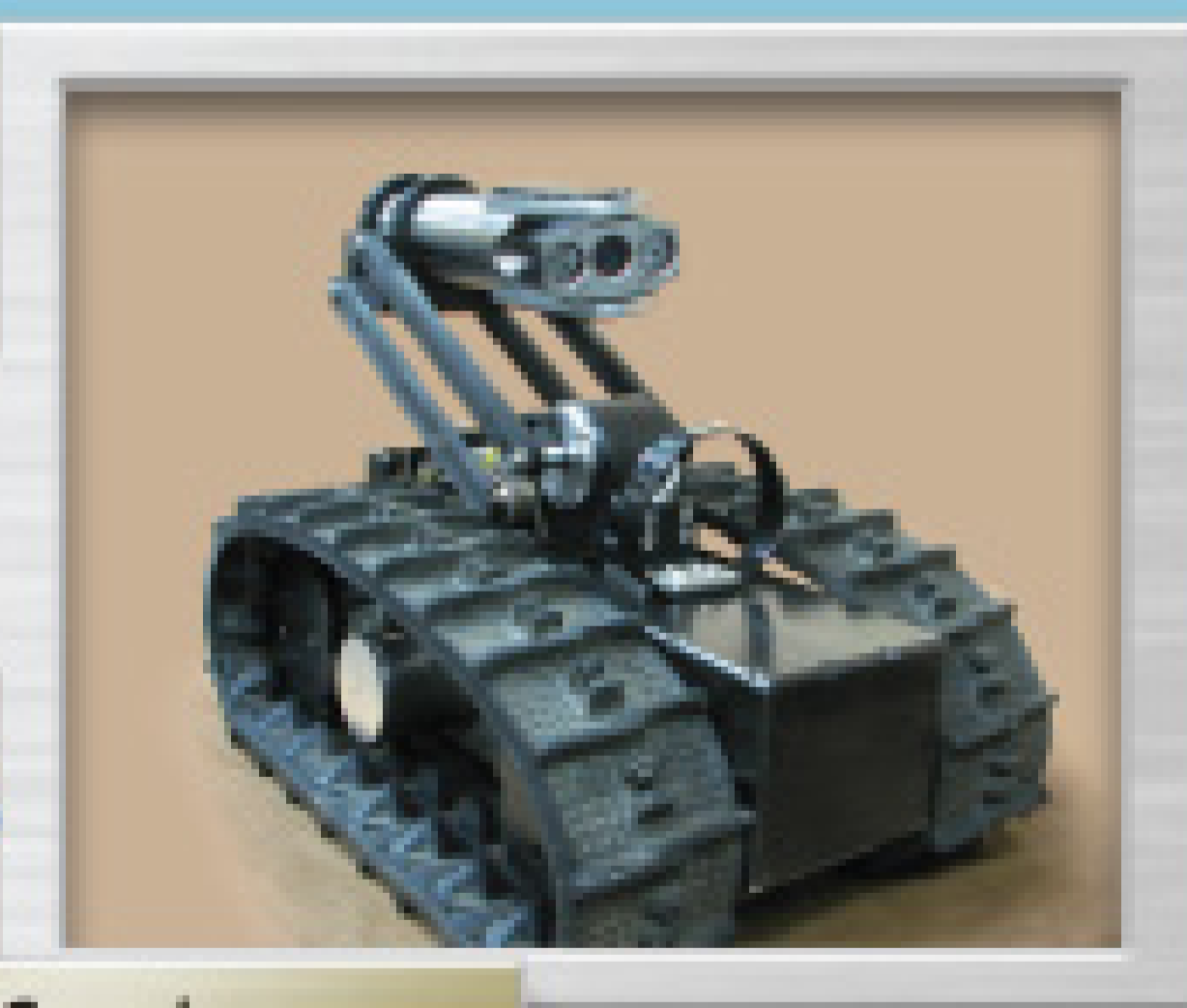

www.cobratec.com Sales: 800.443.3761 E-mail: sales@cobratec.com



RENTALS • SALES • USED

“America’s
Longest Standing
VACTOR Dealer”
VACTOR
Subsidiary of Federal Signal Corporation

Southern California & Southern Nevada

VACTOR RENTALS

Rent a wide variety of Vector, Elgin and Guzzler Equipment throughout the Western United States

Fresh Reconditioned
Units **in STOCK**

**NOW WITH TWO LOCATIONS
TO SERVE OUR CUSTOMERS**

Haaker Equipment Company

2070 N. White Ave. • La Verne, CA 91750

909-598-2706

&

Haaker Equipment Company

10 W. Mayflower Ave., N. Las Vegas, NV 89030

702-639-0156



New Ridgid
Calendar FREE
With \$500
Purchase

OLDEST NAME IN THE BUSINESS

— Over 100 YEARS OLD —

**Call for the lowest prices on General Machines...
...I'd give them away, but my wife won't let me, SHE'S CRAZY!**

Now Available



CALL FOR
GENERAL
SPECIALS



Special pricing on all General jetters, cameras and machines



Repair Center for:
Ridgid SeeSnake, Gen-Eye, Radiodetection, Vision Technology, Electric Eel & Spartan Cameras
Fast Turnaround Time

Root Rat root cutter nozzle

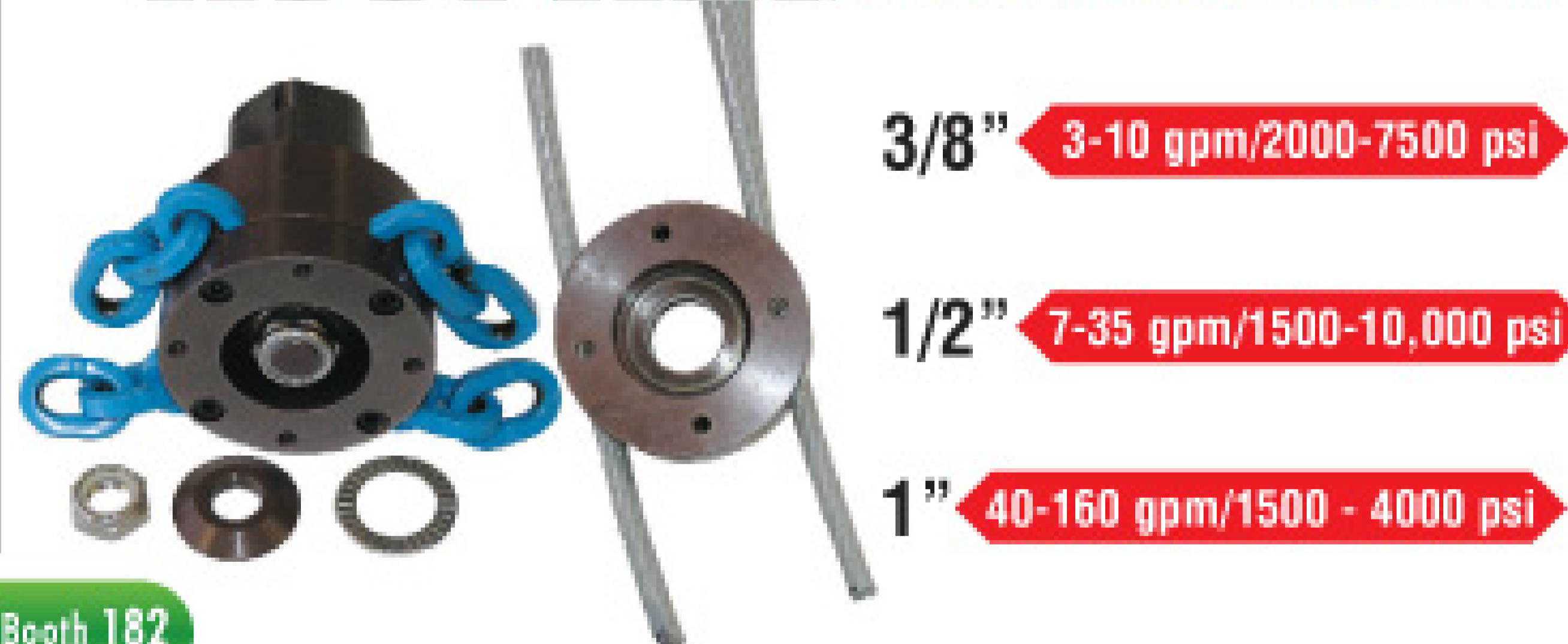

Allan J. Coleman Co., Since 1905 - Call us today! 773-728-2400

"THESE PRODUCTS ARE SO GOOD, WE GIVE YOU OUR ADDRESS!"

5725 North Ravenswood Avenue • Chicago, IL 60660 • www.allanjcoleman.com

PHCC MEMBER

Protecting Your Idea

If you've ever thought of taking an invention to market, here are some strategies for keeping control of what you have created

By Fred S. Steingold

It's a dilemma that perplexes many an inventor: You want to make sure that no one steals your great idea. At the same time, you're reluctant to spend \$5,000 to \$10,000 – or even more – to file a full-fledged patent application through a patent attorney. Maybe you need more time to explore the commercial possibilities of your invention before committing the big bucks.

Fortunately, there's an easy way to resolve this dilemma. You can file a provisional patent application, which will safeguard your claim for up to a year. This is a do-it-yourself procedure that lets you buy time before you decide to take the full plunge.

Like a full-blown patent application, the provisional version is filed with the U.S. Patent and Trademark Office (USPTO).

Many advantages

In their book *Patent Pending in 24 Hours*, attorneys Richard Stim and David Pressman say that filing a provisional patent application offers these benefits:

- You can take up to 12 months to decide if your invention will be profitable before you spend thousands of dollars on a regular patent application.
- You can use a Patent Pending notice to head off competing inventors.
- You can delay building and testing your invention.
- You can establish an official filing date for your invention.
- Your application is kept confidential.
- Your patent's expiration date is extended if your patent is later approved.

In their book, Stim and Pressman recommend that you begin the process by checking on earlier patents so that you avoid spinning your wheels on something that's not really new. You also want to avoid claims of patent infringement. You can conduct much of your research online.

The application

A provisional patent application consists of two main parts: a drawing and a description. The drawing can take many forms. Certainly, a line drawing will qualify, but so will a flowchart, a schematic or a photograph. The drawing must be understandable and fit in a regular file folder.

If you're artistically challenged, review the dozens of practical tips that Stim and Pressman offer in their book. And if you're still intimidated by producing a graphic representation of your

Fred S. Steingold practices law in Ann Arbor, Mich. He is the author of *Legal Guide for Starting and Running a Small Business and The Employer's Legal Handbook*, published by Nolo. Legal strategies may vary depending on the state in which you live and the specifics of your situation. See your lawyer for legal advice.



invention, you can always hire a graphic specialist at modest cost.

The description or text part of your provisional application can be written in plain English rather than in the technical, formal style required for a full application. The heart of the application consists of four types of information:

- The parts or components of your invention.
- How the parts or components connect or interact.
- How your invention achieves its result.
- Alternative ways, if any, that your invention can achieve its result.

If this sounds a bit abstract, don't worry. Stim and Pressman provide several sample applications that you can use as a model for your own. Remember, it's OK to write in the first person: "I invented a device for removing seeds from watermelons."

Feel free to use bulleted lists: They make your application easier to read. To make sure you're communicating clearly, ask a friend to review your application and give you constructive criticism. If you're still uncertain, have a patent lawyer review your work.

Once you've filed your provisional patent application, you can mark your application Patent Pending or refer to it that way.

Finishing up

You can file your provisional patent application by mail or online. You'll find details at the patent office site (www.uspto.gov) or in the Stim and Pressman book. For small businesses, there's a \$100 filing fee; for others, the fee is \$200.

Once you've filed your provisional patent application, you can mark your application Patent Pending or refer to it that way. If you manufacture your invention, mark it – and the packaging – U.S. Patent Pending. But don't do this for more than a year, unless you file a regular patent application.

Although you have a full year to file a regular application, don't wait until the last minute. At least two or three months before the year is up, start preparing your regular application if you're convinced that your invention can be profitable.

You can still file a regular application if you've missed the 12-month deadline, but you'll lose some benefits. For details, see *Patent Pending in 24 Hours*, published by Nolo and available at bookstores and online (www.nolo.com). ■

Working well under pressure!



GET MORE JETTER FOR YOUR DOLLAR!

We include all the options, others charge extra!

UVJ Models
5 gpm @ 4000 psi
Cold Water \$5995
Hot Water \$7995

Fully Loaded Models
7 gpm @ 4000 psi **\$10199**
11 gpm @ 2500 psi **\$11999**
15 GPM @ 3000 psi **\$18399**
20 gpm @ 2000 psi **\$19999**
18 gpm @ 4000 psi **\$37899**

See our complete lineup from economy models, van mounts, portables and more on the web at:
www.camspray.com **800-648-5011**

NEW Models



Don't see what you want? We do custom fabricate!



The Emerson logo is a trademark and service mark of Emerson Electric Co. © 2008, RIDGID, Inc.



GOES ANYWHERE YOU GO.

The RIDGID® K-400 — The Most Portable Drain Cleaner Of Its Kind.

This new, heavy-duty drain cleaner for 1-1/2" to 4" lines is designed specifically for easy maneuverability to, from and on the job site. Its innovative features include a wheeled cart for portability; built-in, telescoping handle for easier transport and storage; and an integrated stair climber design for use in multi-story buildings. Get the K-400 and get going...anywhere you want.

Learn more and schedule demonstrations: 800.769.7743 or www.RIDGID.com.

**We
Build
Reputations™**

RIDGID®

EMERSON.
Professional Tools

DIAGNOSTICS

PRESSING

PIPE & TUBE TOOLS

DRAIN MAINTENANCE

POWER TOOLS

ENZ USA INC

STRONG, FAST AND ENGINEERED TO LAST!

READY FOR ACTION!

PUT A NEW SPIN ON LIFT STATION CLEANING!

- **ELIMINATES WASTEWATER DISPOSAL.**
Emulsifying the grease allows the operator to pump the wastewater to a treatment plant.
- **FAST & EFFICIENT.**
Just lower the nozzle into the wet well and reach all the spots you want to hit in a matter of minutes.
- **SCOURING FORCE & DEBRIS-FLUSHING.**
Four radial rotating jets propel water, cleaning the walls, then act like a blender at the bottom liquefying grease chunks suitable for treatment.
- **5 models available to fit connections from 1/2" - 1-1/4"**



CALL 877-ENZUSA1 FOR
(369-8721)
A DEALER NEAR YOU

ENZ USA INC. • 1585 Beverly Ct., Unit 115 • Aurora, IL 60502

www.enz.com



Golden Jet Radial RotoJet
RGS Nozzle (Type 01.100A/LS)



For over 38 years, KMT Aqua Dyne has been supplying water blasting equipment to the water jetting industry.

KMT Aqua Dyne can provide a total solution for any industrial cleaning or surface preparation needs.

Join the thousands of customers worldwide who come to depend on KMT Aqua Dyne to do the job right!

BLASTMAX™ is Our Most Popular & Versatile Pumping Unit for Industrial Cleaning, Surface Preparation & Petro-Chemical!

Water Blasting Dump Gun used for cleaning & surface preparation

Water blasting Rotary Gun used for ship cleaning

KMT Aqua-Dyne
aqua-dyne.com
713 864 6929

Booth 8079

Join The Rooter-Man Team

WWW.ROOTERMAN.COM

ROOTER-MAN®

"To The Rescue"

See us in Louisville February 2009

Booths 9015 9115

AS SEEN ON TV

New Concept In Franchising

NO ROYALTY ON PERCENTAGE OF SALES BASED ON POPULATION

Exclusive Territories Available

Reserve your Territory, Call 1-800-700-8062

FRANCHISE PACKAGE \$7,950.

ARIES INDUSTRIES

IN-LINE CUTTING SYSTEMS FOR ALL APPLICATIONS



DC 70 • 4" - 10" PIPE & ELBOWS



DC 60 • 3" - 6" PIPE & ELBOWS



RAPTOR • 6" - 15" PIPE



FNF • 10" - 24" PIPE

**Sewer Cutting Systems
for pipe preparation
and pipe opening in
buildings, laterals
and mains**

Grinding, Cutting, Opening

Air Motor styles & bits for all applications & materials

Call **800-234-7205** for more information

Visit Aries Industries at the Pumper & Cleaner Expo
in Louisville, Booth #1008



Wisconsin - 1-800-234-7205 • California - 1-888-285-0366
Florida - 1-800-327-4346 • Mississauga ONT - 1-877-730-7010

FOCUSED ON THE WORLD'S INFRASTRUCTURE

ARIES®

Collection System Maintenance & Rehabilitation Equipment

Proven Infiltration Control With Chemical Grouting

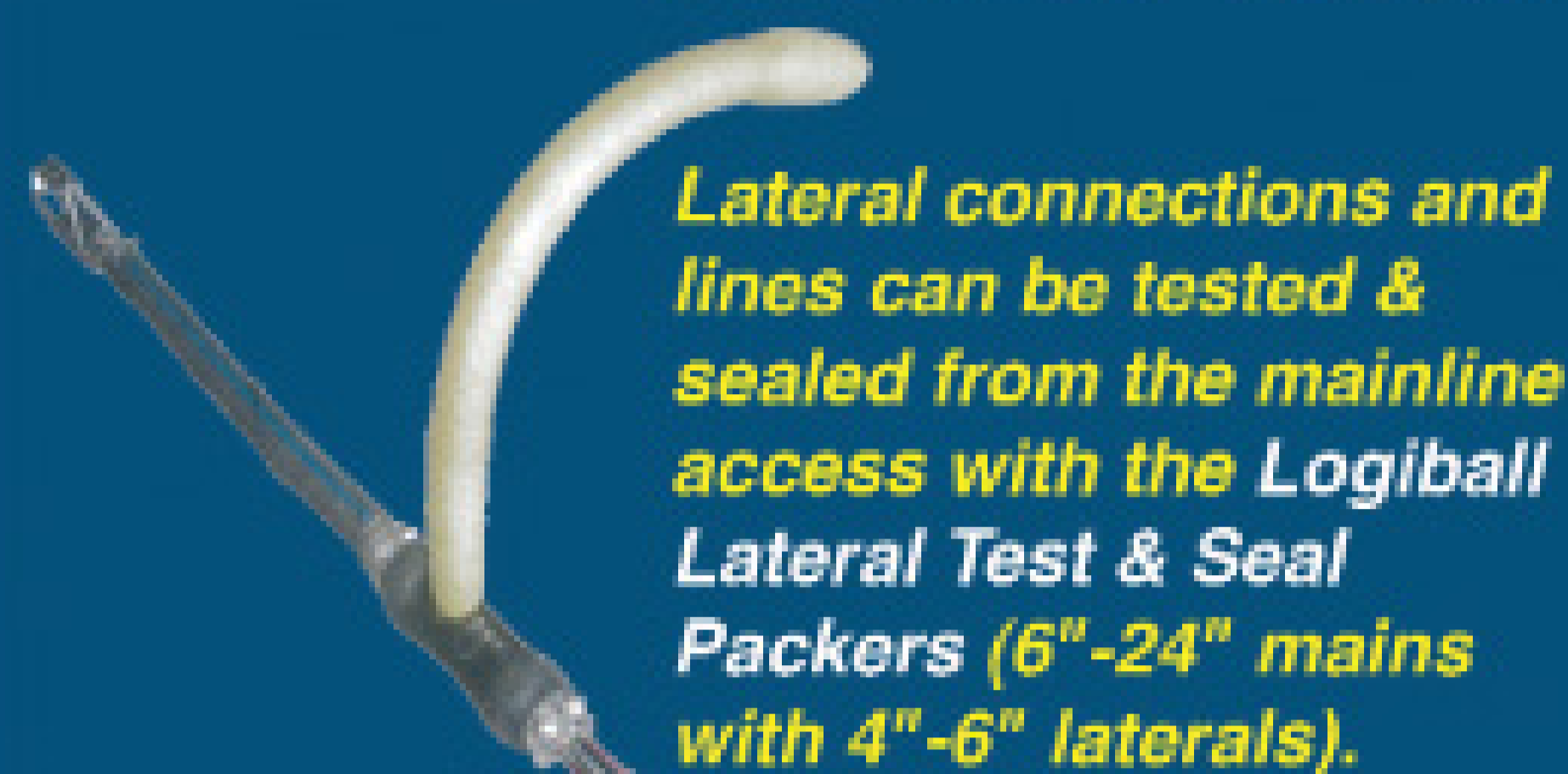

Lateral connections and lines can be tested & sealed from the mainline access with the Logiball Lateral Test & Seal Packers (6"-24" mains with 4"-6" laterals).

Lateral lines can be tested & sealed from an above ground access with the Logiball Flexible Push Type Packers (4"-6")

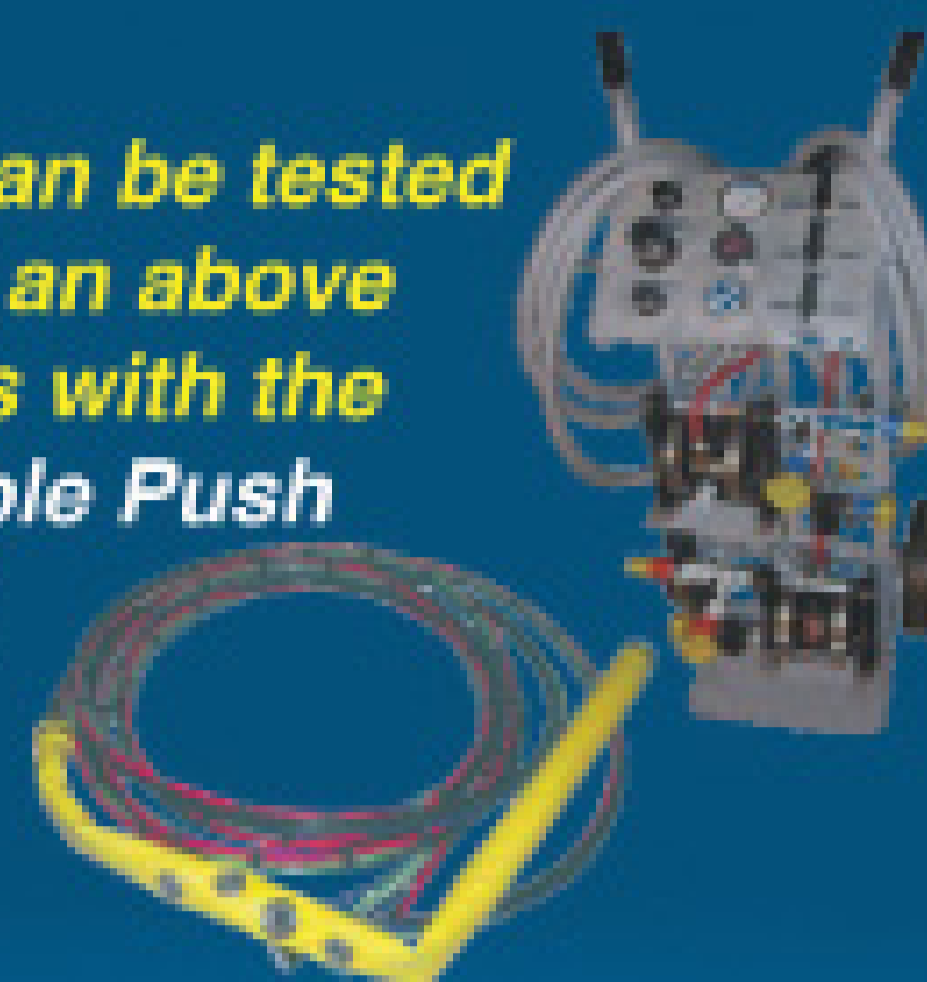

Logiball Multi Size Sleeve Installers for your CIP point repairs.



Laterals coming into manholes or man entry pipes can be sealed with the Logiball Man Entry Lateral Packers (4"-6")



Logiball Multi Size Plugs, large flow thru, testing & blocking



Logiball Lateral Cleaning Launcher to clean lateral lines from the mainline sewer



Mainline joints can be tested & sealed with the Logiball Test & Seal Mainline Packers (6"-144" pipe). Packers available for box culverts & elliptical pipes.



Logiball^{INC.}

Tel: 1-800-246-5988
Tel: 1-418-656-9767
Fax: 1-418-653-5746
www.logiball.com

COBRA SEWER CLEANING HOSE

Bringing together 25 years of U.S. and European engineering/manufacturing technology.



COBRA Sewer Cleaning hose by **Poly-Flow** is engineered and manufactured to handle the toughest and most harsh conditions found in high-pressure sewer cleaning and jetting applications. **COBRA** features a tough polyether-urethane cover that offers maximum resistance to cutting, abrasion, various chemicals, and fungus. Cover colors conform to industry standards for maximum operating pressure ratings. For safety assurance, Cobra sewer cleaning hose is factory tested and sold as assemblies only.

To locate your nearest distributor contact us.....

(503) 493-0015



All Cobra products are manufactured in accordance with WASTEC specifications.

Leaders in cutting technology.



Checkout our New Website bowmantool.com

Come visit our booth and check out the **NEW Dominator J-Series**



- » Dominator® Cutters
- » Classic 615's Repair Parts
- » Rugged Jumbo 1236 Cutters
- » Generation II Infinite Controls
- » Redesigned Air Motors

We are a service-minded company. Call us for a demonstration of the unmistakable Dominator® with a range of 4-30" and powered by the smaller, quicker Generation II Infinite Control.

FREE TRAINING AT OUR FACILITY ON OUR PRODUCTS!

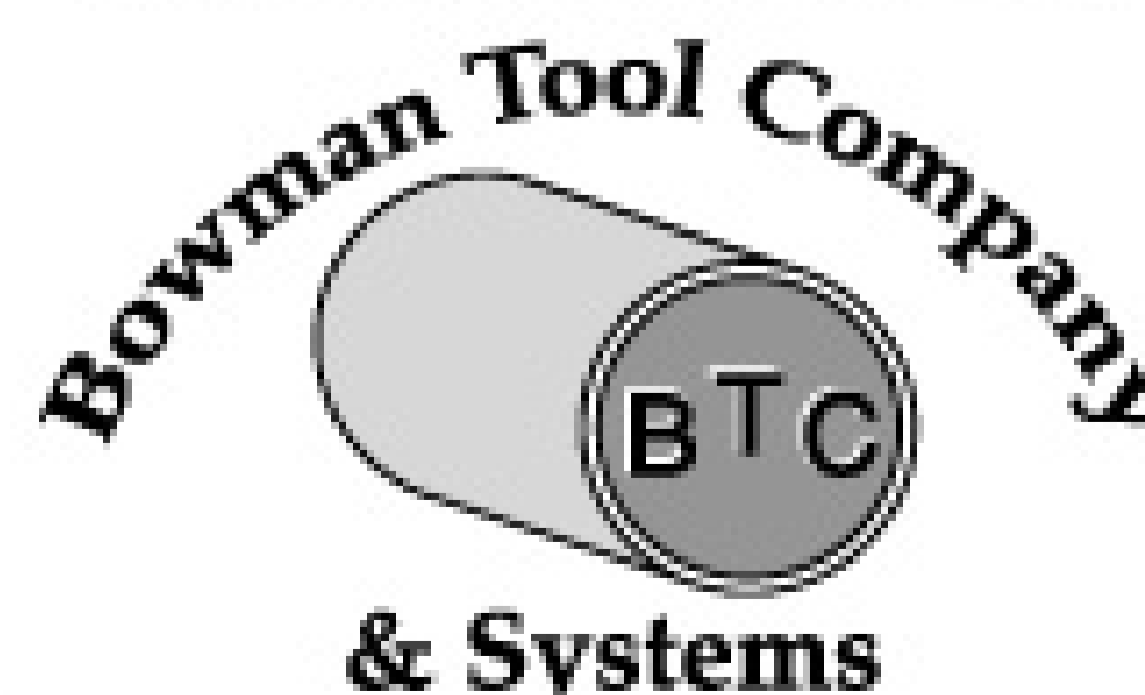

717-432-1403
Fax: 717-432-0152
bowmantoolco@earthlink.net
www.bowmantool.com



GORLITZ SEWER & DRAIN INC.

10132 NORWALK BLVD.
SANTA FE SPRINGS, CA. 90670

TEL: (562) 944-3060
FAX: (562) 944-7630
E MAIL: sales@gorlitz.com

Here at Gorlitz everything comes together just like the Rubix Cube: Engineering, Dedication, Quality and Service.

Your One Stop-Shop would not be complete without offering you Peterson Pressure Bags
General Augers • Piranha Hoses & Fittings
Ridgid Detectors and Cameras
Channel Lock Hand Tools
Kirkhill Plungers

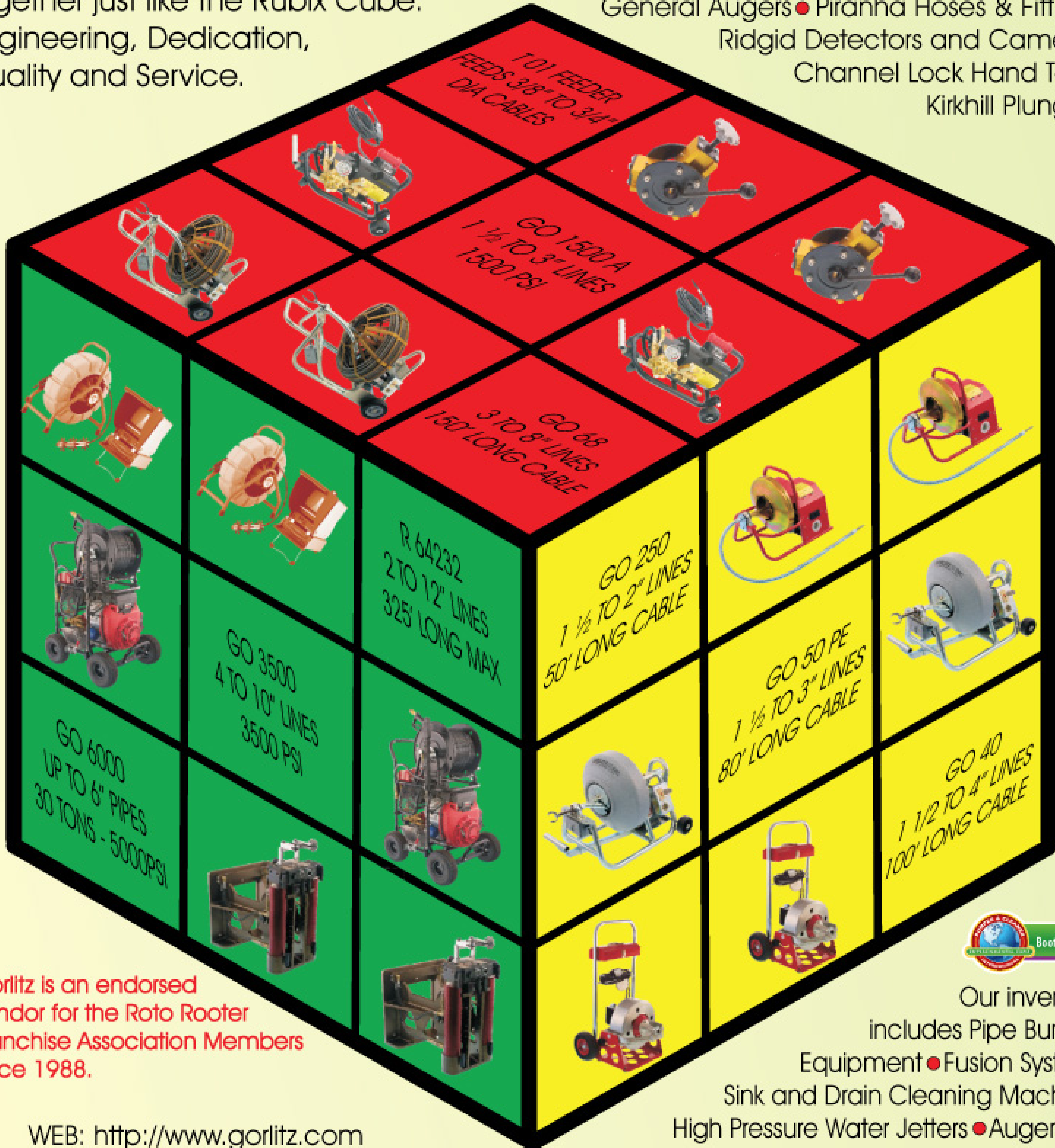

Gorlitz is an endorsed vendor for the Roto Rooter Franchise Association Members since 1988.

WEB: <http://www.gorlitz.com>

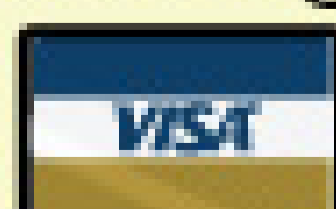

SHOP WITH CONFIDENCE - ORDER ON LINE



Our inventory includes Pipe Bursting Equipment • Fusion Systems
Sink and Drain Cleaning Machines
High Pressure Water Jetters • Auger and Sewer Cables • Connectors • Knives and Blades
Leaders • Retrievers • Rooter Tools and Accessories related to the Drain Cleaning Industry.



Starting Over

Farrell Brown invested in video technology and relaunched his business as an inspection and cleaning service. Now he's added pipe bursting and pipe lining.

By Erik Gunn



Top photo, Mark Tomlinson and Alex Marchuk of Sewer Line Video Inspection make sure the pipe, pulled from the other side by a Pipe Genie bursting unit, goes in without incident. Lower photo, Marchuk runs a SeeSnake inspection camera from RIDGID into a pipe. (Photography by Patrick Botz-Forbes)

California plumber Farrell Brown's success is an unusual mix of new and old.

Brown has spent the past several years reinventing his business, step by step. A native of South Africa, he spent 20 years as a service plumber in the Greater Los Angeles area. In 2000, he decided to take a new direction, focusing on sewer inspection.

The success of his company, Sewer Line Video Inspection Co. Inc., has been "unbelievable," he says. He has branched out even further, adding pipe bursting and, later, pipe lining to his portfolio, working from the Woodland Hills area northwest of L.A. His target customers? Other plumbers, who hire him as a subcontractor.

"I have a group of plumbing companies that I've had since the day I started," Brown says. "They keep me busy every single day."

Brown has employed some up-to-date business strategies, zeroing in on a niche market and embracing new technology. Yet there's something refreshingly old-fashioned about the keys to his success: Know your stuff. Respect your customer. Build relationships. Show up on time.

A great cheerleader doesn't hurt, either, and Brown's wife and

business partner, Lynda, is just that: "He's a very, very good plumber and very confident in his knowledge," she says. "Other plumbers liked that. The guys clicked with him, and then they felt comfortable always calling him."

Long way from home

Brown learned the plumbing trade back in South Africa, where he spent seven years at it until he immigrated to the United States in 1979. "I liked Los Angeles because the weather was great," he says. "It's got everything you want – the beach, skiing in the mountains. And the business opportunity here was unbelievable. But most important was the weather."

He first worked for a plumbing contractor who hired him and agreed to sponsor him for a green card. That only lasted a few months, though: His sponsor fell ill and

PROFILE

SEWER LINE VIDEO INSPECTION CO. INC., WOODLAND HILLS, CALIF.

OWNERS: Farrell and Lynda Brown
 FOUNDED: 2000
 SPECIALTIES: Pipe inspection, location, trenchless rehabilitation
 EMPLOYEES: 6
 ANNUAL REVENUE: \$800,000
 WEB SITE: www.sewerlinevideo.com

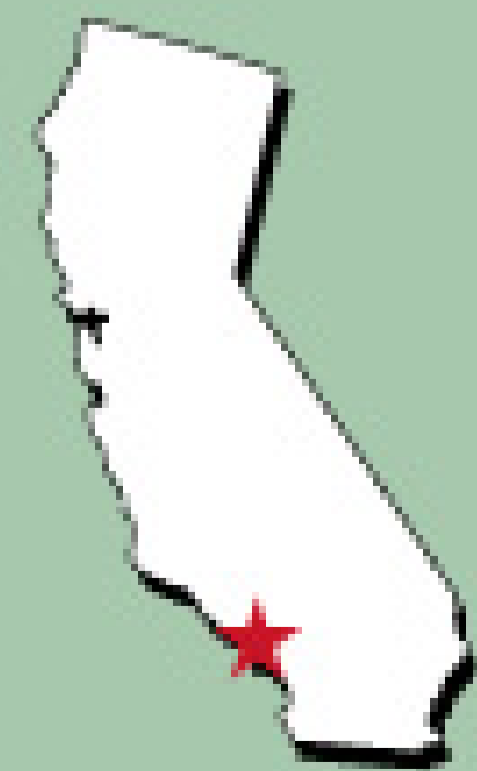



Members of the Sewer Line Video team: owner Farrell Brown, Alex Marchuk, Mark Tomlinson, Jose Carlos and Esaias Zspon.

decided to close the business. "He said, 'Don't worry about it,'" Brown recalls. "Go out and get work on your own, and I'll still sponsor you to become a legal resident of the United States."

Brown got a state contractor's license and started his own business. With a dash of humor, he dubbed the business Farrell Faucet Plumbing, punning on his own first name and that of actress Farrah Fawcett of TV's "Charlie's Angels."

In those days he focused on ordinary plumbing, primarily repairs – garbage disposals, water heaters and the like – as well as sewer repairs, drain cleaning, remodeling and some new construction. The business got big enough for him to own two or three service trucks.

"I did OK, but it was always a struggle," he says. "I was a very good technician, but not a good business-

man." As he got a little older, the work started wearing on his body.

Making a break

He needed a change, but couldn't imagine which direction to go. "The only thing I knew was plumbing," Brown says. "I didn't even know how to turn a computer on."

He credits Lynda with the breakthrough. From time to time as a plumber, he had jobs where he needed to hire a locating company to find a sewer line, or a video inspection contractor to examine one. Lynda suggested he learn that

same level as we are. You're going to be doing water heaters and breaking your back. You need to invest the money and take a chance."

He bought a pair of RIDGID cameras and learned to use them. He changed the company name to Sewer Line Video Inspection Co., sold the Farrell Faucet truck, and bought a new Ford E350 cargo van.

A focus on fellow professionals instead of the general public made selling a lot more straightforward. "I was dealing with plumbers who talk the same language," he says. "It's less stressful for me to explain

"Every step we took, she said, 'Farrell, we have to take risks. If we don't take the risk, we're going to be sitting at the same level as we are. You're going to be doing water heaters and breaking your back. You need to invest the money and take a chance.'"

Farrell Brown

aspect of the business, and she figured out how to market it.

"My wife is really the business brain," Brown says. "She said, 'We're going to go to other plumbers and subcontract to them.'" He was worried about the size of the investment in camera gear, but Lynda spurred him on.

"Every step we took, she said, 'Farrell, we have to take risks. If we don't take the risk, we're going to be sitting at the

something to a plumber than it is to a homeowner."

He also saved on advertising costs. "We made a mass mailing to about 5,000 plumbing companies in the Los Angeles area," Brown says. "Lo and behold, the next day I had an immediate response. I had people calling, and I gave them a good deal."

Selling experience

Brown admits he underbid his more established competitors so he could gain a foothold in the market. He also offered something many firms already in the business lacked: experience.

"The guys I used to call out to assist me in locating sewer lines and things like that weren't really even

A NICHE IN REAL ESTATE

Sewer Line Video Inspection Co. has found one niche market outside its usual group of customers: Real estate agents call him for inspection before home sales. Most of that business comes to him by word of mouth.

Home inspections have long been a standard condition when a house is sold, and many real estate brokers have added sewer inspections to that package. "Should there be a problem, sewer laterals are very expensive to repair or replace," Brown says. When inspections do turn up problems, Brown often gets the repair work.

plumbers," Brown says. "I could offer my customers a much better service with my knowledge, and give them a better deal."

It paid better, too. He found it easy to charge a set rate for a camera job, which he almost always finished in less than 90 minutes. "I got in, I got out, I picked up the check and left," he says. "It was very easy for me. I did four or five jobs a day just on my own."

Growth was rapid, and he hired a second worker. Business kept growing, along with his reputation, which spread almost entirely by word of mouth. "All the advertising was done by the plumbers," Brown says. "I saved an enormous amount of money."

Profit margins grew, but so did competition. "I started noticing after two or three years that plumbers were starting to buy their own cameras," Brown says. Worried that he would lose business, he decided to diversify in 2003, adding pipe bursting with Pipe Genie equipment from Trenchless America Ltd.

Beautiful systems

Brown was an enthusiastic convert to the trenchless technology, once again working as a subcontractor to plumbers. "It was a beautiful system because you didn't have to tear up lawns," he says.



Farrell Brown checks the chain on the pipe-bursting unit as he prepares for a pull.

Three years later, Brown diversified again, adding cured-in-place pipe lining, using the MaxLiner USA process. "Instead of digging up the streets and punching holes, all we have is one hole," he says. "We shoot the liner into the line, going all the way up to the city sewer, allow it to cure, pull the balloon out and then bring the inspector back for a final look at it. We can line a lateral sometimes for 50 percent or even 70 percent less than it would take to dig up the street. It's become really profitable."

The combination of services became like a three-legged stool for his business. "One thing went hand-in-hand with the other," Brown says.

A lot of the inspection and locating work is routine, such as when someone is remodeling a home and simply needs to know where all the sewer lines are. But about 25 percent of his camera jobs lead to bigger work when the inspections uncover major problems that call for repairs.

In addition, other plumbers regularly call in Brown to install CIPP lining in laterals connecting to municipal sewers.

Because he's established such a strong rapport with his plumbing customers, he's found it easy to sell them on his additional pipe-bursting and CIPP lining services. The advantages of those systems are readily apparent to other plumbers (not to mention their customers), and he has earned their trust over the years.

Farrell Brown's personal style helps keep them. "I have a way about me," he says. "I think it must be my accent." By focusing on plumbers as his customers (in addition to getting some calls from the public), he has built good communications that keep business coming back time after time. "They would



Breaking cones on the bursting unit are used to shatter the existing clay pipe.

"The guys I used to call out to assist me in locating sewer lines and things like that weren't really even plumbers. I could offer my customers a much better service with my knowledge, and give them a better deal."

Farrell Brown

talk to me like I was a psychiatrist," he says. "I could get on the same level with them."

His advice to those who would hope to copy his success? "Be very

punctual. Be very personable. And you've got to know what you're doing. That's the big key. That's a thing you learn as you go along. Experience is worth a bundle."

And one other thing: Don't poach from plumbers who provide work. "I would never approach their customers," he says. "You cannot do business with somebody and then go behind their back."

Today, he and his wife have four employees. The original E350 has given way to two 2008 vans of the same make and model. The firm uses five RIDGID SeeSnake or Mini SeeSnake cameras, along with three DVD color monitors and four NaviTrack locators, also from RIDGID.

For pipe bursting, Brown uses the Pipe Genie 40-ton pulling machine equipped with 400 feet of 5/8 grade 100 alloy chain and a 6-inch shark fin with pulsating water. For cleaning lines, he uses two cable machines: a Gorlitz 68 HD and a Spartan 1065, along with a RIDGID 1000 rodding machine. He also uses a Gorlitz 35 hydrojetter.

Timing is everything

Lynda Brown points out that the switch to Sewer Line Video Inspection was a case of being at the right place at the right time. Farrell Brown promptly got a California C-42 bonded sewer contractor's license to go with his C-36 standard plumber's license, she notes. And the marketplace for inspection and cleaning services was still uncrowded a decade ago.

It's different now, as growing numbers of franchise operations vie for the same business. "We couldn't start it today because of the competition," says Lynda Brown. "The customers we've established are the ones that we got in 2000 and 2001."

Today's economy hasn't dampened his success. Brown is modest about it when talking to plumbers because he doesn't want to encourage them to compete against him. "I'll say, 'I'm OK, I'm doing all right,' but in the meantime, I'm doing unbelievable," he says. "Customers call me every single day, day after day, and I don't have to advertise anything." And when it comes to second lives, you can't do much better than that. ■

We have the ultimate bin and shelving system for your vehicle.

Hackney

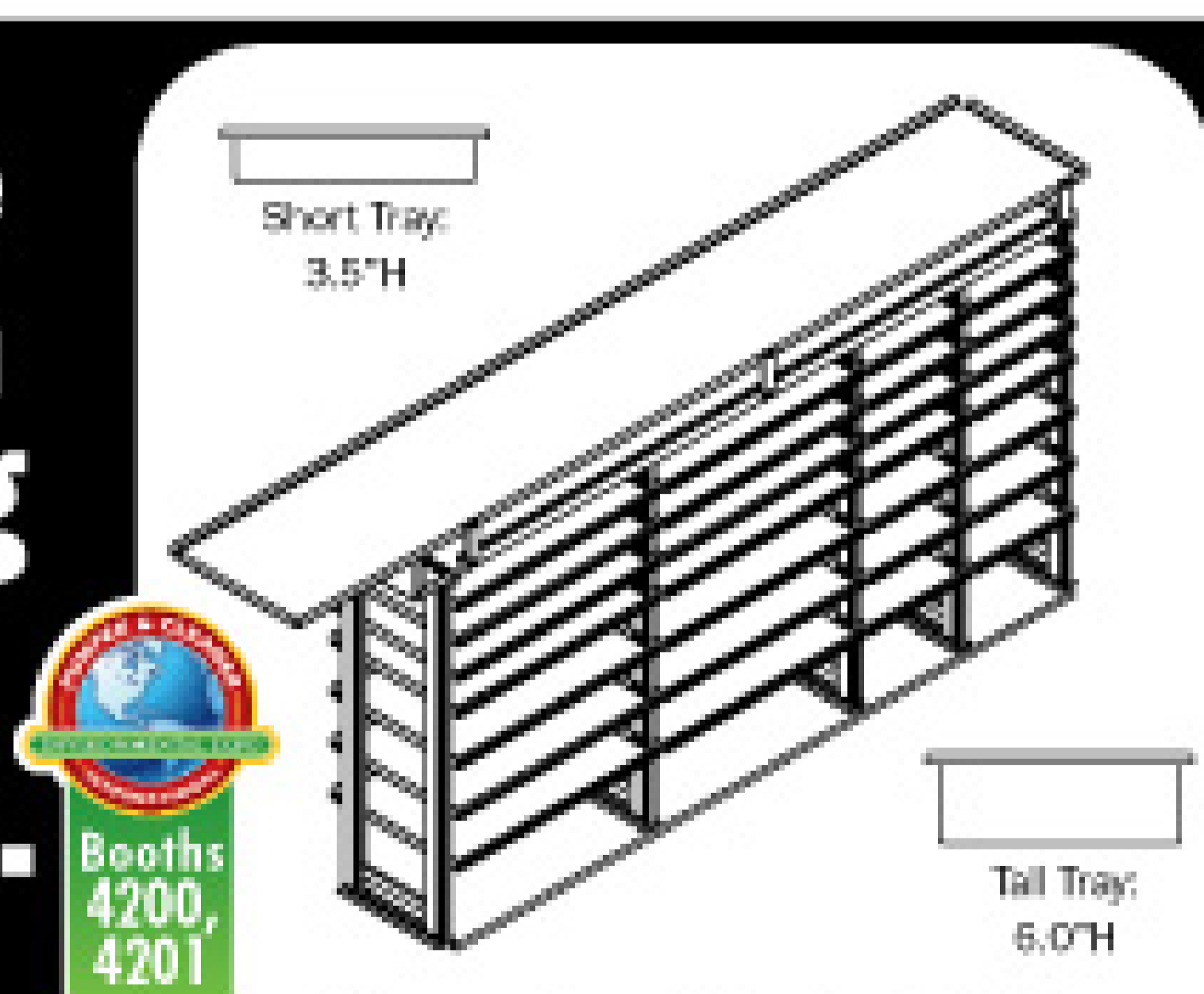

Call Derreck or Randy toll free
1-877-238-7278

MORE INFO:

Gorlitz
877/446-7548
www.gorlitz.com

MaxLiner
276/656-1225
www.maxlinerusa.com

Pipe Genie by Trenchless America Inc.
877/411-7473
www.trenchlessamerica.com

RIDGID
800/769-7743
www.ridgid.com

Spartan Tool LLC
800/435-3866
www.spartantool.com



Lateral & Mainline Inspection



Laser & Sonar Pipe Profilers

GRANITE^{XP}
Asset Inspection / Decision Support Software

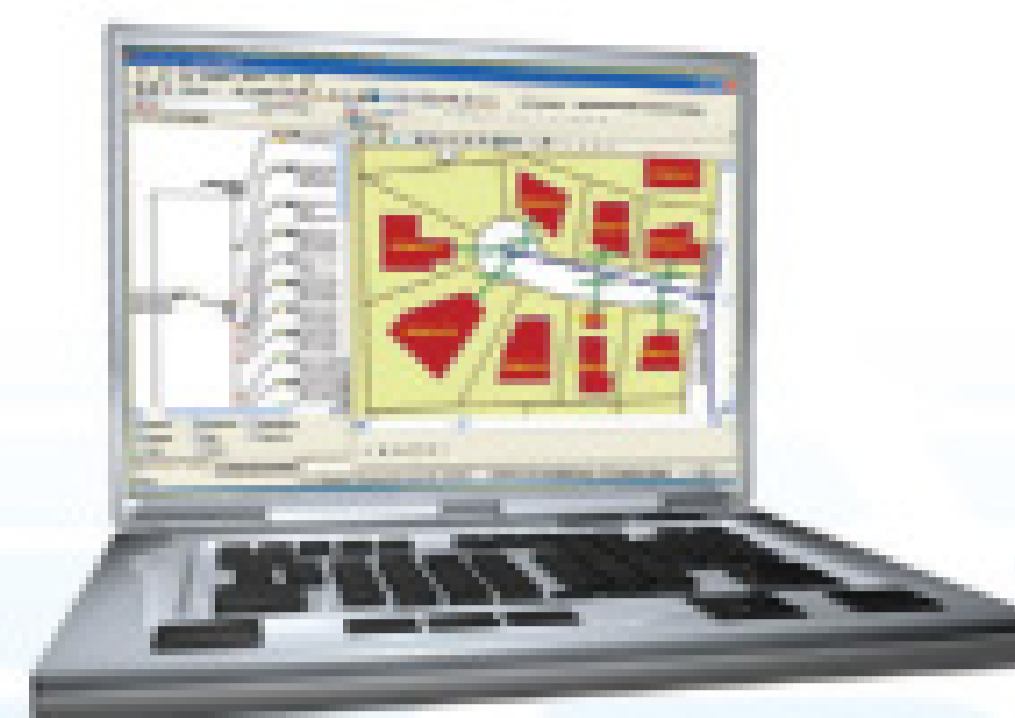

Portable Systems



Mini Systems



Cameras & Transporters

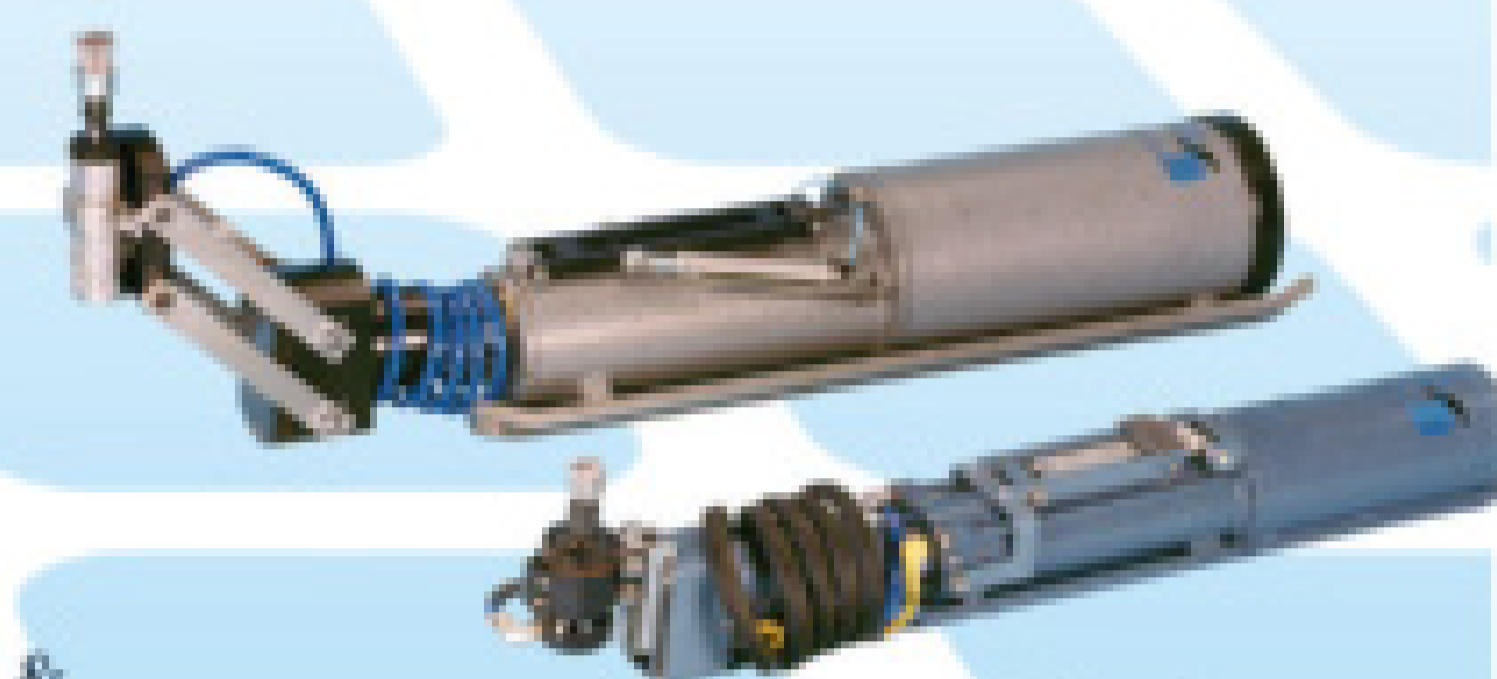

Lateral Reinstatement Cutters

Your One-Stop Shop!

"The Standard of the Industry"



For over 40 years, CUES has provided CCTV pipeline inspection solutions by combining industry know-how, top-of-the-line equipment, and the most responsive customer service in the industry. CUES offers the highest caliber equipment available with a streamlined, one-stop shop for all of your pipeline inspection, rehabilitation, and profiling needs. If you're looking for ways to achieve precision condition assessment to accurately determine the course of your rehabilitation and capital improvement programs for your water, wastewater and stormwater systems, contact CUES for a discussion and demonstration.

Custom Truck, Van, ATV,
& Trailer-mounted Systems



stop by & visit us!



800.327.7791

salesinfo@cuesinc.com

www.cuesinc.com

Booth 1068

You Can't Buy A Better Reel. But You Can Get One FREE.

Come to the Hannay
Booth #3161 at this year's
Pumper & Cleaner Expo
and register to win the
Hannay washdown reel.

Hannay Reels are uniquely designed
to make your job easier.

- ✓ Reels can be customized to meet your exact specifications.
- ✓ Heavy-gauge steel frames, one-piece axle assembly, special bearing design and our exclusive "ribbed" discs can stand up to the most demanding jobs.
- ✓ Superior swivel joints allow for easy access and installation.

So make sure you stop and register
at our booth, and you could walk
away a winner with a brand new
Hannay reel!

For more information,
call us at **877-467-3357**
or visit us online at
www.hannay.com



N700 Model

Hannay Reels®
The reel leader.

www.hannay.com • 877-467-3357

ultra ultra ultra
LIGHT – VERSATILE – SAFE

ultraSHORE
P R O D U C T S



Quick to Install.
As light as 130lbs.

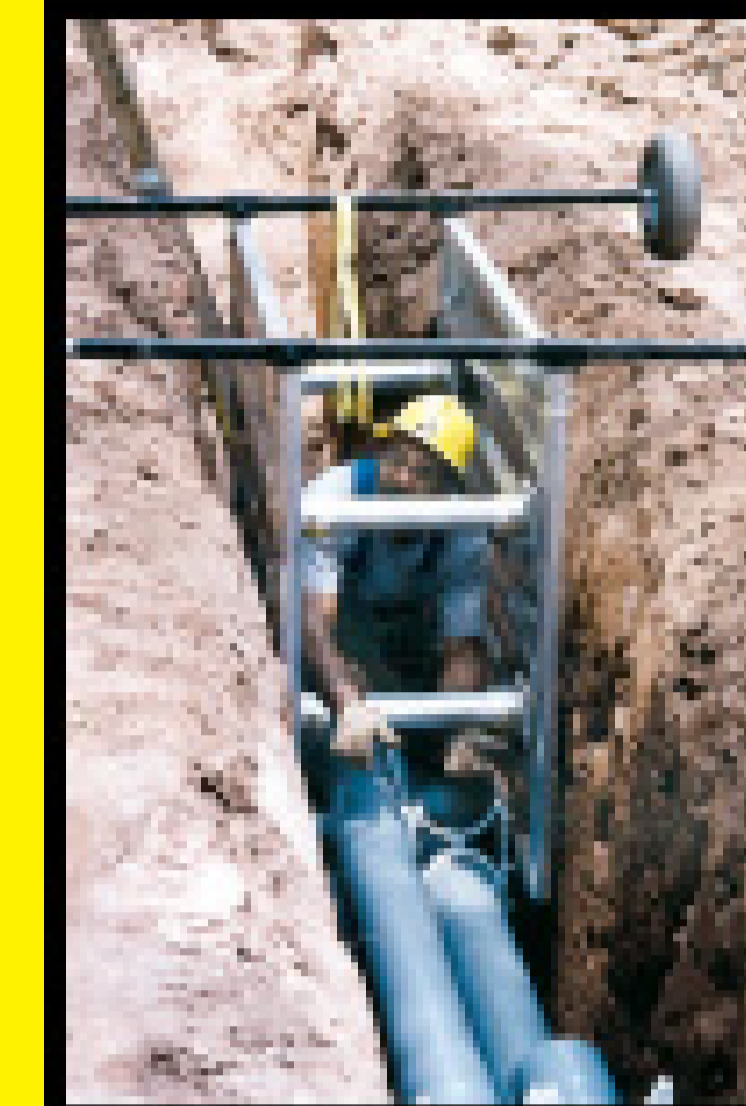

Roll Your Own.
Optional wheel kit.



Stacks easily with
2' & 4' high panels.

This is What Aluminum Shoring Was Meant to be!



1-800-683-8837

1-800-SH-ORING

CALL TOLL-FREE NATIONWIDE • 1-800-746-7464

www.shoring.com

flushquip inc. 1.800.295.1669

We have solutions for your sewer cleaning problems

Please call, fax
or email your
request for a
complete catalogue

Fax:
1.204.697.4790

Email:
ubaziuk@mts.net

1900 Brookside Blvd.
Winnipeg, Manitoba
R3C 2E6

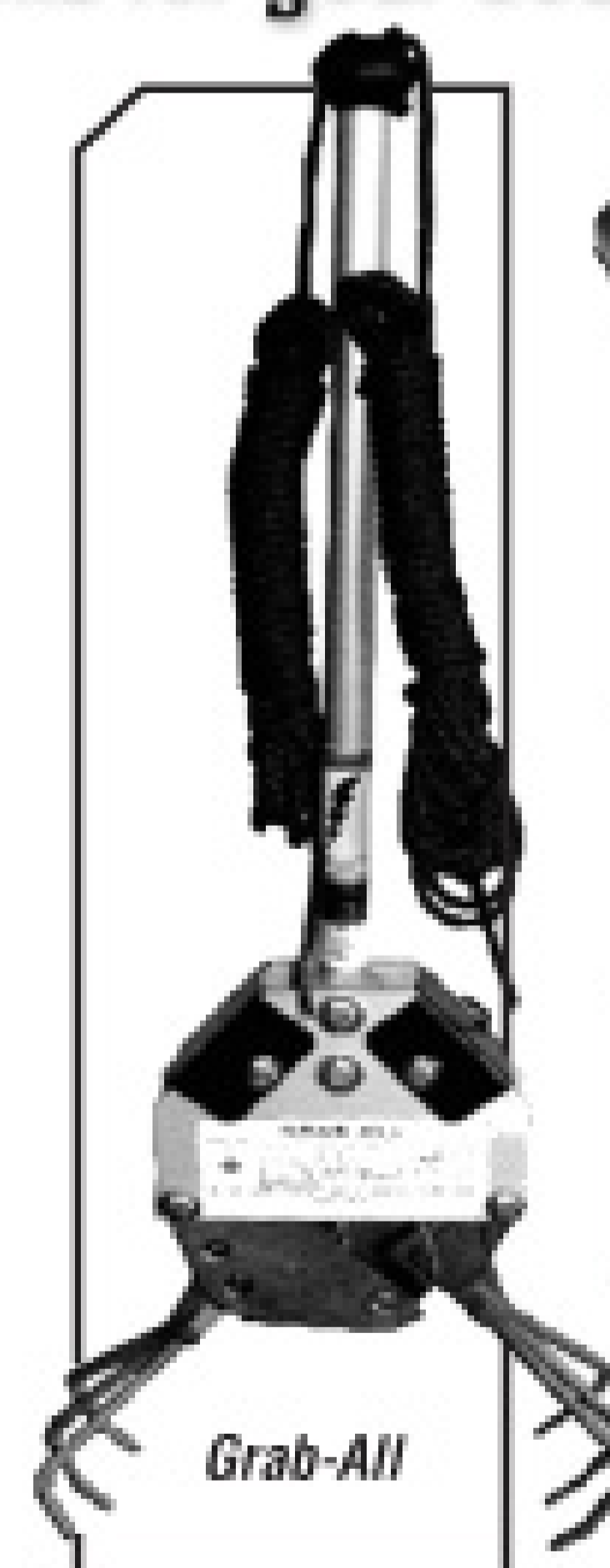

Grab-All



Rocket Nozzle



Penetrator
Nozzle



Finned Fantail



Torch Nozzle

Also check out our website:

www.flushquip.com

RIDGID

UPGRADE

#31763 SEESNAKE® LCDPAK

See everything,
go anywhere
and free up space
in your truck.

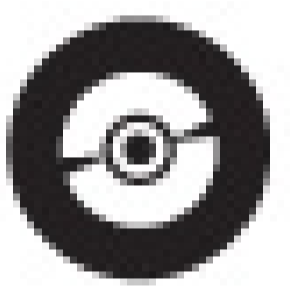

>LIGHTER, SMALLER SIZE
>OPTIONAL RECORDING ACCESSORY
>BATTERY-POWERED

The new SeeSnake LCDPak Monitor features a full-size color display in a significantly smaller case with the battery-powered freedom you need. With its new line trace capability, you'll be able to trace the entire push cable. Be one of the smart ones and upgrade with the RIDGID SeeSnake LCDPak Monitor.

Learn more and schedule demonstrations:
www.RIDGIDUpgrade.com



The Emerson logo is a trademark and service mark of Emerson Electric Co. ©2009 RIDGID, Inc.

We Build Reputations™ | **RIDGID**

EMERSON
Professional Tools

DIAGNOSTICS

PRESSING

PIPE & TUBE TOOLS

DRAIN MAINTENANCE

POWER TOOLS



FROM LATERALS TO MAINLINES TO STORM DRAINS. . .

There's so much more you can do when your crews are running RST systems.

- Interchangeable cameras, tractors and crawlers to perform fast, accurate inspections in lines 4" to 200" in diameter and up to 3,000 feet in length
- Cameras feature high intensity white LED lights
- 40:1 Zoom with automatic iris and focus available
- Portable, truck and trailer mount configurations



GET MORE. DO MORE. RST.

Call today for more info about our custom-fit inspection tools for municipalities and sewer service contractors.

VEHICLES | CAMERA SYSTEMS | SOFTWARE

■ EXPO Booth #4069 ■

800 767 1974

www.rstechserv.com

RS Technical Services Inc.
Design and Manufacture of Video Pipeline Inspection Systems

The SOIL SURGEON™

The **MOST POWERFUL** HYDRO-EXCAVATING TOOL ON THE MARKET!

Use your sewer combination truck to:

- **LINE LOCATE** • **POTHOLE**
 - **TRENCHING** • **BASIN CLEAN**
- (within minutes)

- Fits all truck manufacture designs
- Quick connects to 8- or 6-inch boom
- You control water flow pressure and power with the truck's controls
- Is designed to cut through all types of soil

Features include:

- 6-foot tuff tube
- "Y" connection for water and/or air
- Handles for easy maneuvering
- Water ring with tips boring inward to cut the soil and outward to get tube down
- Bumpers on bottom to protect tips and line



SOIL SURGEON INC.
Patent #6,484,422B1

NEW AND IMPROVED STEEL PIPE THAT REPLACES HOSE! REPLACEMENT KITS AVAILABLE FOR CUSTOMERS WHO HAVE OLD MODEL.

Call For A Free Video and Info. on Your Nearest Distributor
949-363-1401 • www.soilsurgeoninc.com

Introducing Lindhorst Nozzles

State of the art conical ceramic inserts

The All Star Kit is a complete self contained case featuring all the best nozzles available in each class. Arm your operators with a complete arsenal to deal with any potential line condition.

<p>LHD-30.16 Chisel Point Use: Blockages of all types Features: • 8 Rear Jets for maximum thrust to ram blockages • 4 forward jets to clear stubborn blockages • Aggressive chisel shape & tool steel blasts through obstructions</p>	<p>LHD-10.16 Rotating Nozzle Use: Cleaning crowns, general cleanup of newer installations Features: • High speed spinning barrel scours crowns effectively • Excellent cleanup of newer lines plus PVC • Right angled cleaning jets direct maximum force to the pipe wall to tear away grime</p>	<p>LHD-40.16 Radial Nozzle Use: Every day workhorse Features: • 8 rearward dual angled jets for optimal coverage & cleaning power on the pipe wall • Optional forward jet allows for forward cleaning (shipped plugged)</p>	<p>LHD-20.16 Grenade Use: Main Line Cleaning especially larger lines Features: • 10 rearward dual angle jets maximize cleaning & minimize streaking • Massive 3"x6" size for stability in larger lines • Aggressive jet design creates exceptional vortex vacuum action for maximum finish cleaning</p>	<p>LHD-60.16 Torpedo Use: Long pulls and hills Features: • Aluminum lightweight body maximizes velocity • Used for difficult long runs & hills, this is the ultimate pulling nozzle • Low cost hardened steel insert design</p>
--	---	--	--	--

Introducing The Best In German Engineering And American Design

LINDHORST
WORKHORSE NOZZLES

Conical ceramic inserts hold their dimension longer, directing maximum energy at the wall of the pipe. Debris explodes on contact. The finest German tool steel and high quality finish, maximize your horsepower!



702.324.2244

www.Lindhorstnozzles.com

Dealer inquiries invited.

Building A World of Solutions

Blower Repair



Waterblast Rentals

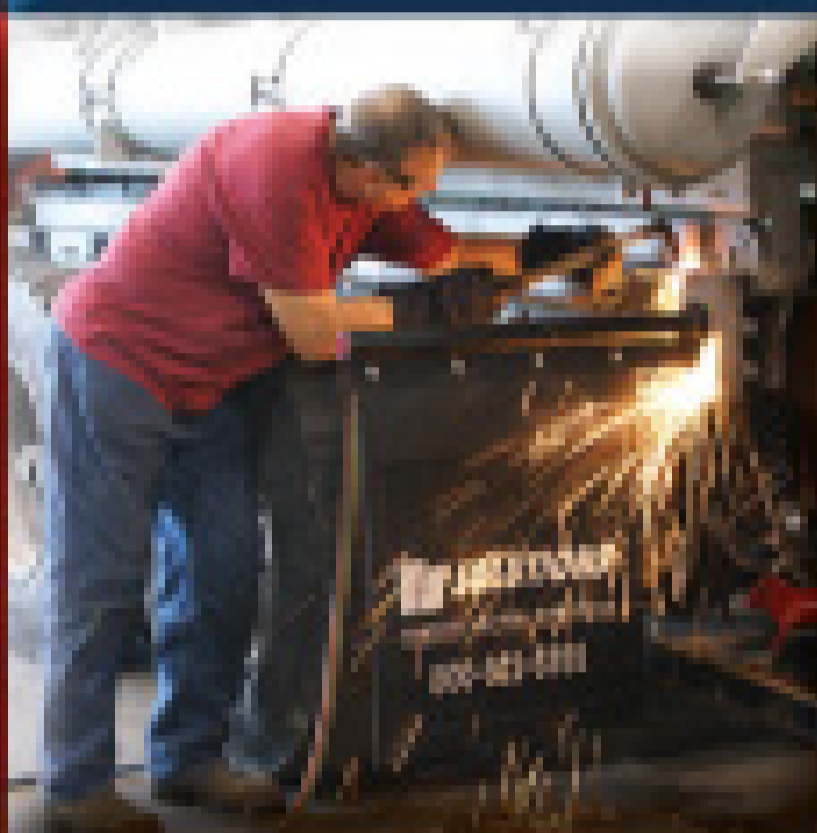

Equipment Refurbish



Parts



Used Equipment



Accessories

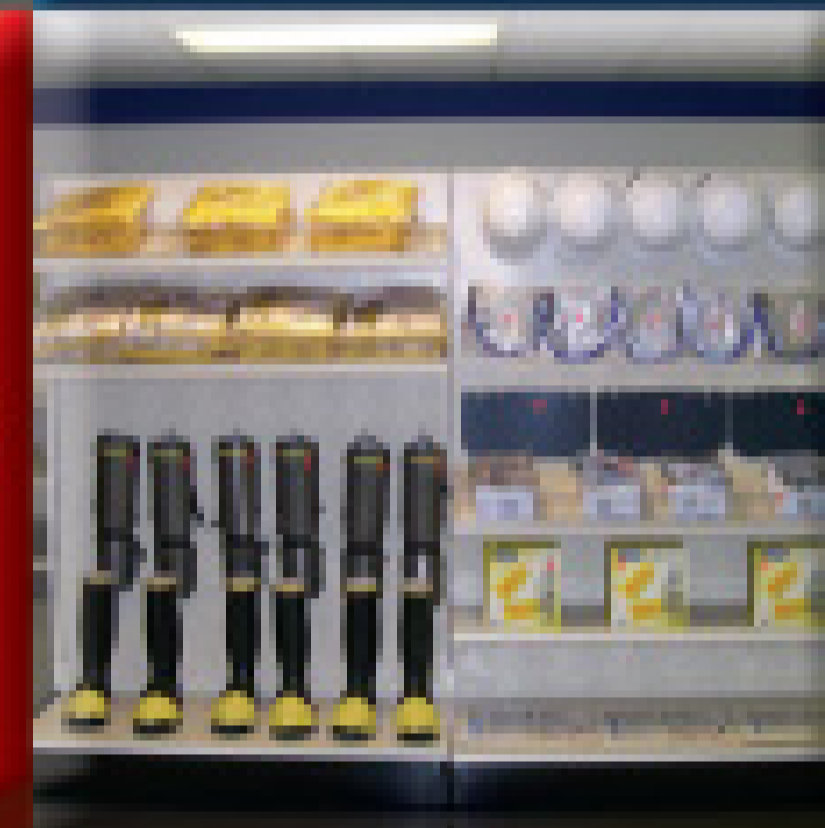

Training



Huge Selection of Used & Refurbished Trucks!



Unit #05123 1997 Guzzler ACE,
 Roots 1021 DVJ 27", New Paint,
 Hydraulic Boom
READY TO WORK!



Unit #44184 2005 International 7600,
 Guzzler Classic, New Debris Body,
 New Hibon SIAV 8702 Blower
READY TO WORK!



Unit #K2534 2009 Sterling 7501,
 Keith Huber Liquid Vac, Demag Rfl
 100 Pump, 3000 Gallon Debris Tank
READY TO WORK!

Many More Units Available • Warranties for Most Equipment we Sell and Service

1.800.822.8785 www.fssolutionsgroup.com

Nate Rodriguez vacuums oil and fuel waste from a storage tank inside United Industrial Services in Meriden, Conn. Rick Fielding, another UIS worker, supports the vacuum tube. (Photography by Johnathon Henninger)

The Old Is New Again

A business born amid the oil shocks of the 1970s now prospers in a new era of high fuel prices and environmental awareness

By Mary Shafer

The first oil crisis in the mid-1970s opened David Carabetta's eyes to the reality that earth's resources are finite and need responsible stewardship.

The epiphany launched his company, United Industrial Services, in Meriden, Conn. It operates on a "total recycling" business model, reusing everything from the wastes the company collects to the containers they are shipped in.

It's an ideal setup for a diverse business that includes industrial cleaning and vacuum loading of waste from customers and internal processes. How these processes fit into the company's larger mission is a lesson in planned, scaled, service diversification.

A strong, clear vision, combined with hands-on management, has helped the company secure its bottom line in an uncertain world.

Born of necessity

Carabetta formed United in

1976. It is now a privately owned company with 12 facilities in five states. "We started in the agricultural business, looking for alternative fuels in the 1970s fuel crisis," Carabetta recalls. At that time, there was a need for more industrial services, so the firm expanded into spill cleanup as United Oil Recovery.

Carabetta soon realized that waste products had potential value as fuel, and he created methods to process those materials to fulfill that potential. That led to calls for more services, says Tom Pappalardo, special projects manager.

The firm now offers dozens of services, from emergency spill response and industrial vacuum loading to transportation, storage and treatment of various hazardous and regulated wastes. The firm serves New England and the northeast corridor states, and customers include companies in manufacturing, aeronautics, construction and demolition, pharmaceuticals, textiles, and property management, as well as municipalities.

United owns and operates transfer, storage and treatment facilities in Meriden and Bridgeport, Conn., and Stoughton, Mass., that have permits from the federal EPA Resource Conservation and Recovery Act (RCRA), Part B. The company also has transfer and storage facilities in Northborough, Mass., and Newington, N.H. The main office and vehicle maintenance facilities remain in Meriden.

Sustainable growth

Though expansion has been rapid at times, it has always been planned. "Our growth was a combination of various acquisitions, and our desire to minimize our environmental footprint," Carabetta says.

What comes in as waste may leave as a saleable product. What comes in as a waste container may leave as a processed bulk material headed for a recycling plant. "What

"Our growth was a combination of various acquisitions, and our desire to minimize our environmental footprint."

David Carabetta



A view of one of the many storage rooms at United Industrial Services in Meriden, Conn. Waste removed from spills and collected from industrial sites are processed in Meriden.

we collect, we transport," Carabetta says. "We generate waste from some of our field service projects, and then we treat it. Our treatment plants then generate fuel, such as when we capture thermal energy from the incineration of hazardous materials."

material matches its profile and satisfies permit criteria.

One of the marketable products created through the waste treatment process is Norlite, a lightweight, porous ceramic material, produced by expanding and vitrifying select

"You need a strong infrastructure to really get into this industry. Anyone can buy a truck and the equipment, but you really need the trained employees, a large and viable customer base, so many things."

David Carabetta

The real advantage is that this diversity evens out the highs and lows in activity and cash flow: Some areas may be slow, while others remain busy.

The company's waste analysis plan requires that all material entering the facilities be sampled and analyzed before shipment. The firm's laboratories assign a specific material profile, which determines proper shipping, storage and treatment. Waste is analyzed again before the truck is off-loaded to verify that the

shale in a rotary kiln. This process, using waste-derived fuel, produces a consistent quality aggregate that's strong, stable, durable and environmentally inert. Engineers and designers use Norlite to reduce dead loads, lower thermal conductivity of building products, improve fire ratings and enhance soils.

Tools of profit

The operation depends on a large fleet and equipment inventory. United operates more than 150

FROM ZERO TO 10 IN FIVE YEARS

The waterblasting service at United Industrial Services has grown from nonexistent to 10 percent of the company's billings in the past five years, "with another percentage to support our own facilities," reports Tom Pappalardo, special projects manager. The Field Service Division does the waterblasting, mostly industrial heat exchanger cleaning.

Internally, it involves confined-space entry for tank and oil/water separator cleaning. "We do some surface preparation, but it's at a lower pressure," Pappalardo says. "It's not a big portion of our work. Most of that is some type of maintenance program: de-scaling, floors, inside storage tanks. Every 10 years, facilities owning above-ground storage tanks need to do an inspection inside tanks and we go in to remove scale before they do that."

United has expanded in part by developing alternatives to liquid blasting. "A lot of manufacturing in the Northeast is in the aerospace industry, and they use some unique coatings," Pappalardo says. "They don't like water, because it can compromise the high-tech metals, so we use dry ice surface preparation. Compressed CO₂ pellets are conveyed through a nozzle similar to a sandblaster to scour surfaces clean. Then they vaporize on impact."

"We'll also take resin and paint off tanks where plastic compounds are made," says David Carabetta, president. "When a batch is bad, we go in to clean that out of the reactor vessel before another batch can be made."

Pappalardo says technology has come a long way. "Manufacturers have taken some of the fatiguing aspects out of the equipment," he says. "Easier trigger pulls, better configurations on rotating nozzles. They've made it much easier to service. Now you can tear down a 20,000-psi unit in an hour.

"The adaptation of high-capacity vacuum units to mobile equipment has increased field productivity the most," Pappalardo says. "It's all a function of fulfilling what our customers ask us to do. We get a lot of requests for problem solving. We're continually looking at projects and asking how we can make the process better."

waste transportation vehicles, including vacuum trucks, bulk tankers, tractor-trailers, box trucks, and vans. For cleaning and pumping, the company has seven high-capacity vacuum trucks, with liquid ring pumps that enable simple and efficient handling of liquid and heavy sludges. Four are fitted with baghouse dust collection and filtration systems to allow loading of dry materials.

United built one truck of each style in-house. The rest use Hibon pumps delivering 3,700 to 3,800 cfm. Two have bodies by Keith Huber Inc., one with a 3,500- to 3,700-cfm pump from Kaiser Pump & Valve Inc., and the other with a liquid ring 3800-cfm pump from Gardner Denver Nash. These trucks also carry secondary low-vacuum blower pumps delivering 400 to 750 cfm.



A 20,000-psi cleaning nozzle used by United Industrial Services.

PROFILE

UNITED INDUSTRIAL SERVICES, MERIDEN, CONN.

OWNER/PRESIDENT:	David Carabetta	
FOUNDED:	1976	
EMPLOYEES:	275	
SERVICE AREA:	New England and northeastern states	
SPECIALTIES:	Industrial vacuum loading, waterblasting, water treatment	
AFFILIATIONS:	Environmental Treatment Council (Washington, D.C.); Expanded Shale, Clay and Slate Institute (Salt Lake City, Utah)	
WEB SITE:	www.unitedindustrialservices.com	



Top: A high-capacity vacuum truck is used to remove soil from a tank on a jobsite (photo courtesy of UIS field service supervisor Joey Verrastro). Right: Tom Pappalardo, special projects manager, points to the gauges reading the vacuum truck's negative pressure and hydraulic pressure.



Besides high-capacity vacuum trucks, United fields about 35 pumper trucks with 3,000- to 4,000-gallon stainless steel waste tanks on Kenworth, Peterbilt, Freightliner and Mack chassis.

Beyond trucks, Pappalardo says United's operation depends on smart growth, and that depends on strong management and staff. "You don't want to grow too fast and get out of control, because you need to maintain quality and efficiency," he says. "That's always a concern."

Building a family

Carabetta adds, "We're very fortunate to have a seasoned group of individuals we've developed over more than 30 years." Like other companies, United finds it challenging to locate quality people, but has no trouble holding on to them. "We treat them well and they take care of us," he says. "We pay well, but it's more than that. We like to look at it as one big family."

Staff development includes exhaustive training for new hires and ongoing professional development. Employees receive hazardous material handling and confined-space entry training. Annual training includes confined-space rescue. United's field employees receive 40-hour OSHA Hazardous Waste Operations and

Emergency Response Standard (HAZWOPER) certification.

Field workers go through safety training, then shadow a veteran driver or field service technician. "All the book learning in the

of the innovation we use to deal with that," he says. "Ninety-eight percent of our managers came from the field,

"It's all about getting in and out of your customers' plants and giving them the least downtime possible. There's lost profit when they have to shut down any longer than necessary. We've been through that learning curve."

Tom Pappalardo

world is great, but you have to see the work happening to really understand it," Pappalardo says. Supervisors decide when employees are ready to work on their own.

United extends safety training to its customers, if requested. "It's not like what you'd see from training-only companies," Pappalardo says. "We do our own in-house training, and customers will ask to join in."

Leveraging experience

Carabetta says the biggest challenge is growing the customer base and offering diverse services while maintaining quality and efficiency. "Our employees are very much part

and they keep their hands in the business. We have always promoted from within. That's how we keep our team tight and retain our employees."

Pappalardo adds, "Facility workers will occasionally express interest in moving to a different position. Within reason, you want to put people where they want to be."

United management is active and involved. Every morning, managers talk to field personnel about what they are doing, who they are doing it for, and what safety precautions they are taking.

Carabetta is clear-eyed about the state of the industry, and cautions would-be cleaning contractors who

think of it as an easy target for instant profits. "You need a strong infrastructure to really get into this industry," he says. "Anyone can buy a truck and the equipment, but you really need the trained employees, a large and viable customer base, so many things.

"I think there's a desire out there for higher quality companies," Carabetta says. "There are a lot of people who supply service, but I think customers are looking for their best option. And that's not always just a price."

Pappalardo agrees. "Just because you have the low bid doesn't make you the best," he says. "It's all about getting in and out of your customers' plants and giving them the least downtime possible. There's lost profit when they have to shut down any longer than necessary. We've been through that learning curve. In presenting quotes, we go over experiences from similar jobs, and show why we're more economical."

He believes the most immediate issues facing environmental cleaning contractors is diversification – giving customers what they need, when they need it.

Carabetta says the most important element of a successful future is the ability to think creatively and innovate. "For instance, we're in the process of a major upgrade at one of our treatment facilities," he says. "The object is to do as much biological treatment as possible, and we let that drive the way we're doing the upgrades. In this industry, you've got to be innovative, so you can be ahead of the curve and not behind it." ■

MORE INFO:

Gardner Denver Nash
203/459-3900
www.gdnash.com

Hibon Inc.
888/704-4266
www.hibon.com

Kaiser Pump & Valve Inc.
903/643-9232

Keith Huber Inc.
800/334-8237
www.keithhuber.com

Check Out What's New From the
Industry Innovator for Over 75 Years

**SRECO
FLEXIBLE**

Bronco Trailer Jetter with JetCam

Kicking Out Even More Productivity

A powerful trailer-mounted jet system featuring high water pressure and GPM delivery at a budget friendly price. System includes an integrated JetCam small mainline video camera with an LCD monitor and built-in DVR for documenting your work.



- ✓ 20 gpm at 4000 psi
- ✓ 325 gallon water tank
- ✓ up to 600' of hose capacity
- ✓ integrated JetCam, LCD monitor and DVR
- ✓ articulating reel

BONUS: connect a Flexicam® push reel and camera to the Bronco's Command Center and you extend your inspection capabilities to include laterals.

The Flexicam® System

SRECO Flexible, one of the most highly recognized names in the manufacturing of sewer maintenance solutions is pleased to present its newly redesigned Flexicam® camera system—the system of choice for assessment of pipes from 2 to 6 inches in diameter and up to 200 feet in length.

- ✓ 100', 150' and 200' cable choice
- ✓ 10" LCD flat screen monitor
- ✓ Built-in DVD recording capability
- ✓ Choice of B & W, Color or Self-Leveling Color Low Lux camera heads
- ✓ Operates on low voltage battery or AC power
- ✓ Locates easily with optional sonde and receiver



Command center features a rugged, wheeled case with telescoping handle for easy transport and set up

Call today for more information about these products and our complete range of wastewater collection systems maintenance solutions.

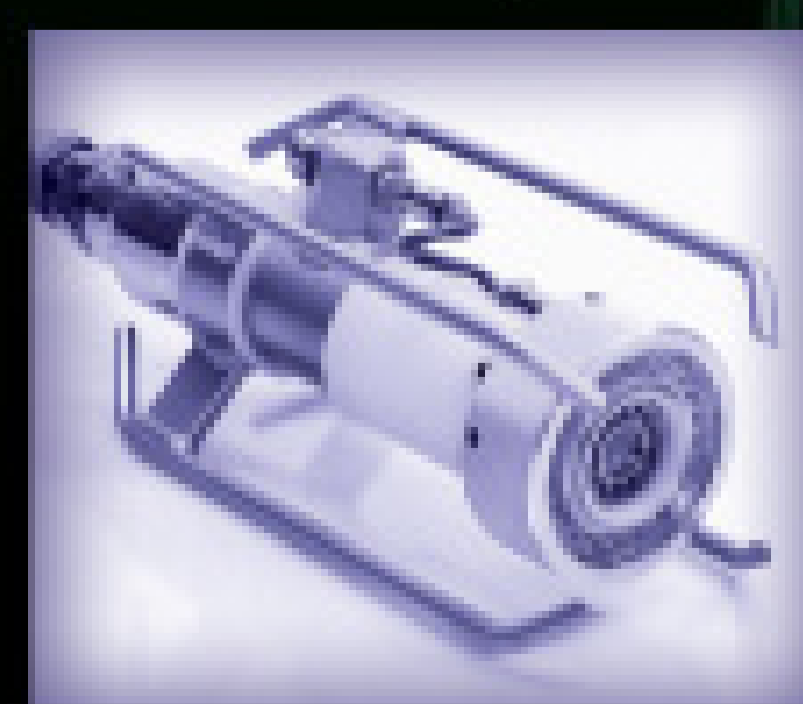

SRECO Flexible...Seventy-Five and More Than Alive!

Toll Free: 800.421.6536
310.606.9009 | 310.335.0124 f
www.srecoflexible.com

Booth #1040

**POWER
CONTROL
PRECISION**

SRECO Flexible...
the equipment you need
to tackle tough cleaning
and inspection jobs
"inside" and "out"

See these
products and
more at our
interactive
exhibit at
the Pumper &
Cleaner Expo

A three lobe blower provides smoother, quieter operation than a two lobe blower. Trust the LEADER IN THREE LOBE TECHNOLOGY.

hibon®
Better by design.



Overheating issues?

Hibon's unique AIR INJECTION design is the most efficient cooling system. Your air injected Hibon blower will pull a higher, continuous-duty vacuum without overheating allowing more vacuum over longer distances and/or better performance when pumping heavier, wetter material.

Contamination issues during washdown?

Hibon uses CLOSED END PLATES which prevent contamination during washdown while improving blower performance and reducing overall noise!

Come and see us at booth #26

IR Ingersoll Rand
Industrial Technologies

Low Pressure Business Unit / Air Solutions
Ingersoll Rand Industrial Technologies
12055, Côte de Liesse
Dorval, Quebec
Canada, H9P 1B4
Tel.: +1 514 631-3501
Fax.: +1 514 631-3502
www.ingersollrand.com
www.hibon.com

Call Toll Free - 800-356-9661
Triple R Specialty

2 MODELS - the 20 H.P. SK3555D or the 24 H.P. SK358D

SKID MOUNTED JETTERS



- 20 or 24 HP Honda GX Engine w/Electric Start
- 6.5 Gallon Aluminum Gas Tank
- 5.5 or 8 GPM @ 3500 PSI Thermally Protected Pump
- 200 Gal. Water Tank w/Low Water Shut-off
- Manual Reel w/ 300' x 3/8" Jetter Hose
- 3 Stainless Steel Jetter Nozzles
- Pressure Washing Gun and Wand, includes Pressure Washing Nozzles
- Skid is Powder Coated and Constructed of Heavy Gauge Aluminum Channel

800-356-9661

www.triplerspecialty.com

We put the BLAST in BLASTer.

(While maintaining Best-In-Class Fuel Economy.)

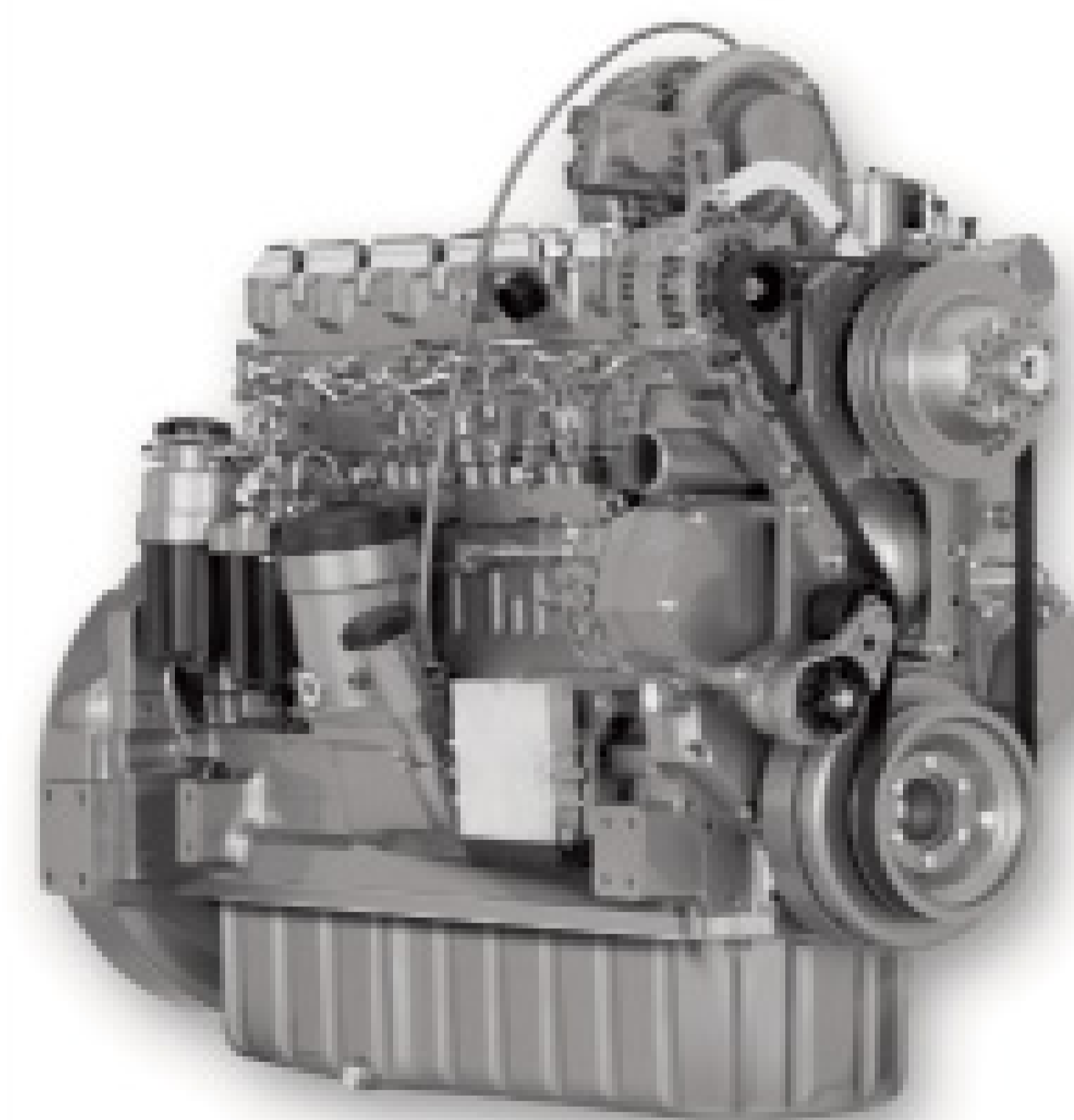

Get more BLAST out of every tank.
John Deere brings together several engine advancements in **PowerTech™ Plus engines** to deliver the highest possible performance and fuel economy. Don't settle for less.

PowerTech™ Plus Diesel Engines meet **Tier III** emissions without sacrificing performance. John Deere has maintained or increased power output from all **PowerTech™ Plus** models, from 49 to 600 horsepower. Powerful. High Performance. Fuel Efficient. Emissions Certified. Environmentally Smart.



engines,inc.
Reliability At Work

Conroe, TX 936-441-5592
Jonesboro, AR 800-562-8049

www.enginespower.com

AUTHORIZED JOHN DEERE ENGINE DISTRIBUTOR

A reliable source of power, a consistent source of confidence.



Low-wear quintuplex pump

Swing-out manifold

Convenient trailer mounting package



NLB 325D

NLB 325 Series: everything you like about the NLB 225, at 400 hp



125D: 115-145 hp



225D: 200-300 hp



605D: 475-600 hp

The new NLB 325 Series convertible pump units have a lot in common with our popular 225 Series — including the parts. That makes maintenance and inventory even easier, while letting you do jobs that require up to 400 hp.

With the 325 Series, NLB again meets customer needs, bringing convertible water jet technology and quick-change fluid ends to quintuplex pumps. We now offer 22 convertible models, the most in the industry, with an unbeatable range of pressures, flows and horsepower.

See for yourself how the NLB 325 can boost your productivity. Call 1-877-NLB-7988 today for a free demo, or visit www.nlbcorp.com.

NLB 325 Series: Available Configurations

Model	GPM	PSI
Model 405 (400 HP)		
24405D	25	24,000
20405D	30	20,000
15405D	40	15,000
12405D	50	12,000
10405D	60	10,000
8405D	74	8,000
Model 365 (365 HP)		
24365D	22	24,000
20365D	27	20,000
15365D	34	15,000
12365D	42	12,000
10365D	51	10,000
8365D	64	8,000

NLB. The Contractor's Choice.



29830 Beck Road, Wixom, MI 48393
 MI: (248) 624-5555, TX: (281) 471-7761, NJ: (856) 423-2211
 LA: (225) 622-1666, CA: (562) 490-3277
 e-mail: nlbmtg@nlbusa.com

Lansas[®] PRODUCTS

MANUFACTURED BY VANDERLANS AND SONS, INC.



Multi-Size Domebeads[™]
Front and Back Plugs



High & Low
Pressure
Joint Tester

Custom Designs Are Always[™] Available



Vacuum Test Plate
with Protective Cover



"Smart Box"[™] Line
Acceptance Test Kit



High Pressure
Plugs ~ to 150 PSI



AR[™] Plugs



Vacuum Pump
Manhole Vacuum Testing



"Super Vac"[™]
Manhole Vacuum Testing

VANDERLANS AND SONS, INC.
California 1-800-452-4902
Atlanta 1-770-509-9309
Minneapolis 1-763-428-9290
www.lansas.com



WESTERN MULE[™]



FOLD-A-WAY
CRANE

The 5-IN-1
BUMPER CRANE

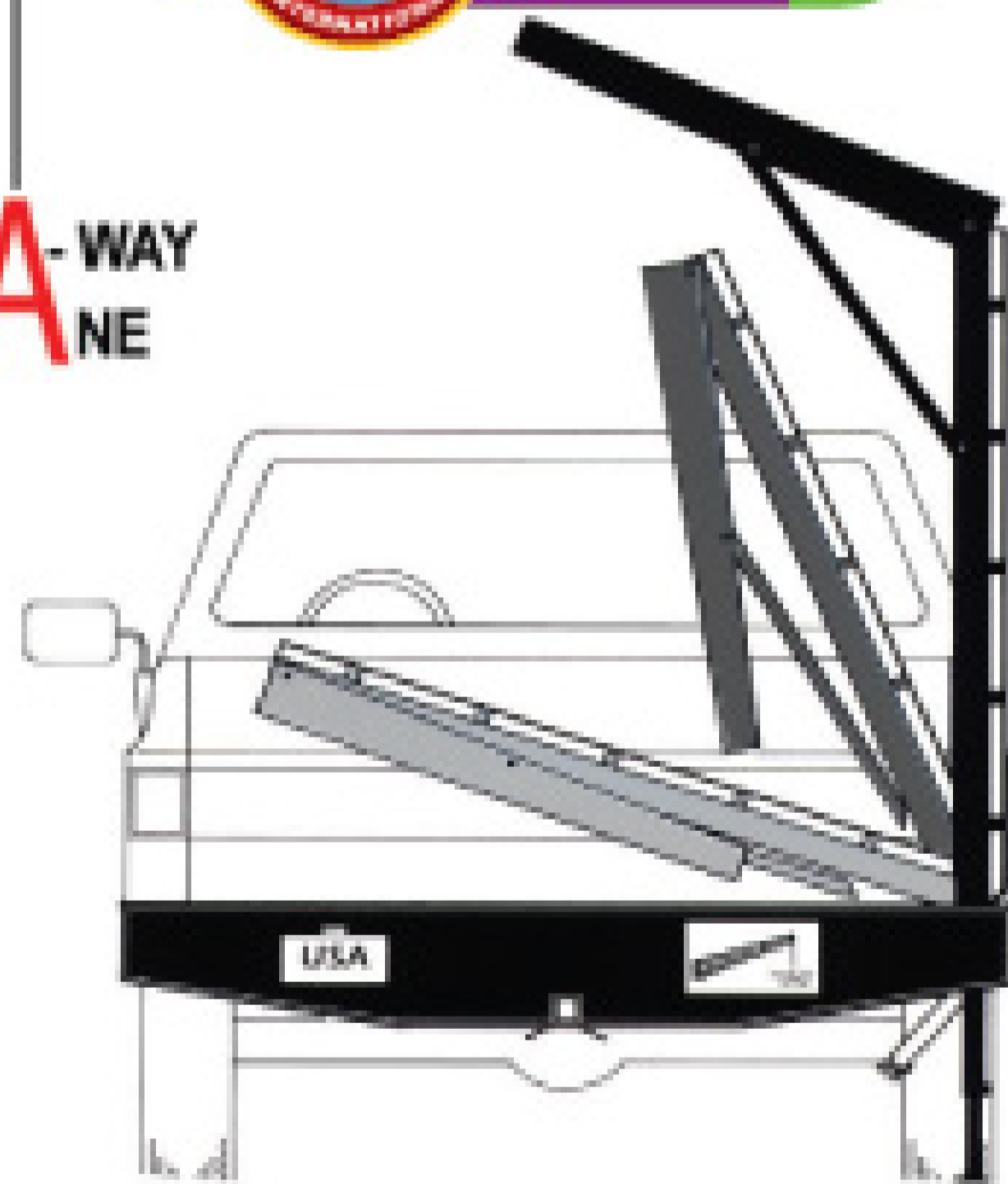

It's a... CRANE .. WINCH .. HITCH .. BUMPER
A MAN-LIFT FOR CONFINED SPACE ACTIVITY



MODELS WITH LIFTING CAPACITY UP
TO 2500 LBS. SAVES TIME, SAVES
LABOR, SAVES YOUR BACK!

1-800-288-6853
westernmule.com
Fresno, CA USA

KEN-WAY Beats the Others DAY-IN • DAY-OUT

And they have for over 50 years

KEN-WAY CABLE CLEANERS

for cleaning sewer, drain or process lines
from one to ten inches, up to 75 feet
with the Junior and up to
a full length of 300 feet
with the Model 400



Junior



Model
400

KEN-WAY Exclusive Built Cables

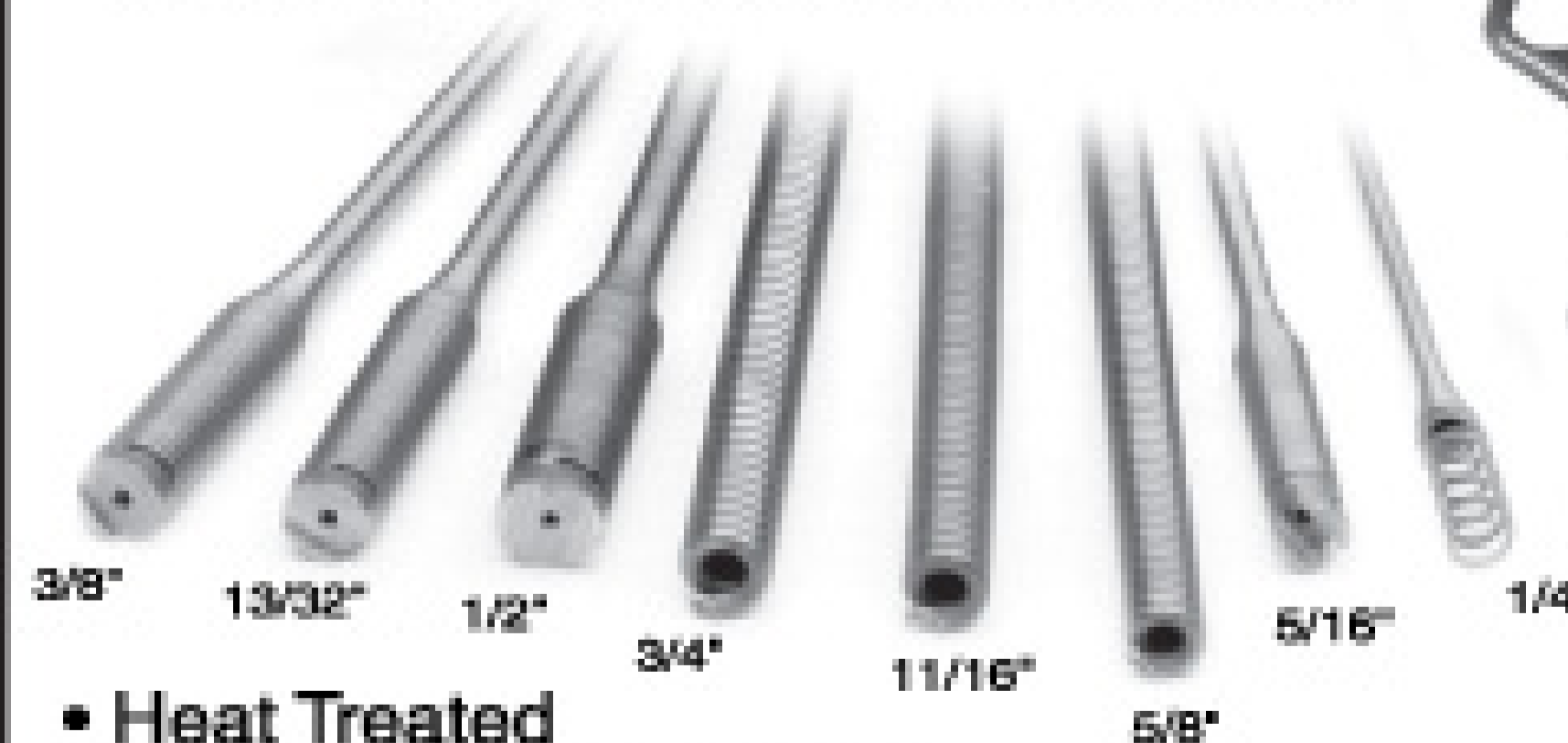

3/8" 13/32" 1/2" 3/4" 11/16" 5/8" 5/16" 1/4"

- Heat Treated
- Inner-Core or Non-Core
- Fit Most Other Brands
- Interchangeable with Most Brands
- Coupling or Blade Holding Types



Leasing plans available. Call for details.
1-800-533-0551

930 ROBERTS ROAD, SPARTA, WI 54656
www.ken-way.com • E-mail: info@ken-way.com

\$ WE'VE GOT THE MONEY \$

For All Your New and Used Equipment Needs



CHUCK TERRITO

- > APPLICATION ONLY TO 250K
- > SIMPLE APPROVAL PROCESS
- > LEASE OR LOAN OPTIONS
- > NEW & USED EQUIPMENT
- > FLEXIBLE FINANCE OPTIONS
- > START UP PROGRAMS



MIKE RAUSCH



Fax this E-Z application to **406.892.5072**, or give us a call, and we will get your financing approved for the show.

Company Name: _____ Owner/Contact: _____

Address: _____

City: _____ State: _____ Zip: _____

Phone: _____ Best time to call: _____

Let us put our 36 years of experience to work for you!

Call today and see why...

IT PAYS TO LEASE WITH US!



Granite Leasing Co.

800.246.7997

www.graniteleasing.com

Spirit and Determination

Despite visual impairment, a Pittsburgh contractor returns to college at age 41, aiming to earn his degree and set an example for his children

By Christa Kolster

When Bob Beall can't be found on the premises of his Mr. Rooter franchise in Pittsburgh, Pa., he can surely be found close to a computer screen.

That's because Beall, at age 41, is pursuing an online college degree in business. Now halfway through his studies with the University of Phoenix, Beall admits it hasn't been easy. Legally blind since birth, he's always been one to persevere. He says his determination to earn a degree is motivated by a greater incentive: self-empowerment and hopes of inspiring others.

"I want to be an example to my kids," he says. "I want to show them how education can be a gift to them. I didn't feel like I could tell my kids to do something I didn't do myself."

With thick glasses, face close to the computer, Beall compensates for his visual impairment. He has always turned disadvantage into advantage. He never believed anything would keep him from striving toward a goal. "It may take me a bit longer to read and type, but I just do it," Beall says. "I've always been persistent."

An inspiration

Despite his visual impairment, Beall followed the footsteps of his father, starting a career as a plumber in 1985 in Cleveland, Ohio. He moved to Pittsburgh, Pa., when a business opportunity presented itself. In 2001, he purchased his Mr. Rooter franchise. Today, he runs the business with 50 employees and \$8 million in sales.

Education plays a big role in the Beall family. He and his wife, Carol, have three adopted children, now pre-teens: J.P., Megan and Alex. They first took them into their care as infant foster children. Carol, a partner in the business but now a stay-at-home mom, has four adult children and five grandchildren. Her oldest son is a teacher in North Carolina with two grandchildren,

"I want to be an example to my kids. I want to show them how education can be a gift to them. I didn't feel like I could tell my kids to do something I didn't do myself."

Bob Beall

Maureen and Audrey. Her youngest son, Brian, works at Mr. Rooter while attending the local plumbing trade school, with the vision of possibly becoming an integral part of Mr. Rooter some day.

Beall's determination to complete his degree has already encouraged Megan to inquire about the educational requirements for becoming a teacher. "I think if you're willing to study, you can do anything," Beall says.

The children race their father to the computer when his grades come through. His nine A's and two B's have brought hurrahs from his cheering squad. "The kids get almost more excited than I do," Beall laughs.



Mr. Rooter franchise owner Bob Beall, and his three adopted children, from right, Megan, 10, Alex, 9, and J.P., 12, check their dad's grades on the computer. Beall is taking online classes from the University of Phoenix in pursuit of a business degree. (Photo courtesy of Bob Beall)

One difficulty during the past year of study has been the time consumed by course work. Completing the class work takes 15 to 20 hours a week, most of it evenings and weekends, as Beall runs his Mr.

Rooter franchise full-time. But neither has it been easy for Beall to return to school after last studying a textbook in 1985, when graduating from high school in Geneva, Ohio.

best for him. "One of the biggest advantages of an online program is the flexibility of the schedule," he says. "I can attest that attending a 'virtual classroom' would work best for anyone with a busy schedule." Business degree online programs vary from one institution to the other. Several colleges and universities offer flexible schedules from which their students can choose. One reason he chose the University of Phoenix is that students enroll in classes that last five to six weeks. That enables him to focus on one subject at a time. Although he already runs a successful business, Beall is convinced the degree will help him in many ways. Already growing his skill in business management, he's bringing new knowledge to areas of leadership, communication, organization and teamwork. He's sure all of that will bring him even greater prosperity and satisfaction. ■

Cyberspace classroom

After ten years as a business owner, Beall believes furthering his education has become a necessity. He decided an online course was

After Hours is an occasional feature that describes how business owners reconcile work life with family, leisure time, charitable pursuits, and personal interests and passions. Cleaner welcomes story ideas. If you take part in something interesting outside work, or if you know someone in the cleaning business who does, please send a note to editor@cleaner.com.



Inspector PC



Fast Peek



Elite DVD



Torpedo Crawler



Mini Mainline

Ratech

Electronics

Video Pipeline Inspection Systems



Mini Peek



Ultra Micro



Plumber's Mate



Elite SD



See Us at the Pumper and Cleaner Expo
in Louisville, Kentucky Booth 144



Toll Free (800) 461-9200 (905) 660-7072 (905) 660-1519 fax
www.ratech-electronics.com sales@ratech-electronics.com





MORO 100+ Years of Quality Innovation.

The Next Generation to be Unveiled Thursday, February 26 at 9:30 a.m. at the Pumper and Cleaner Expo in Louisville.

Don't Be Late!

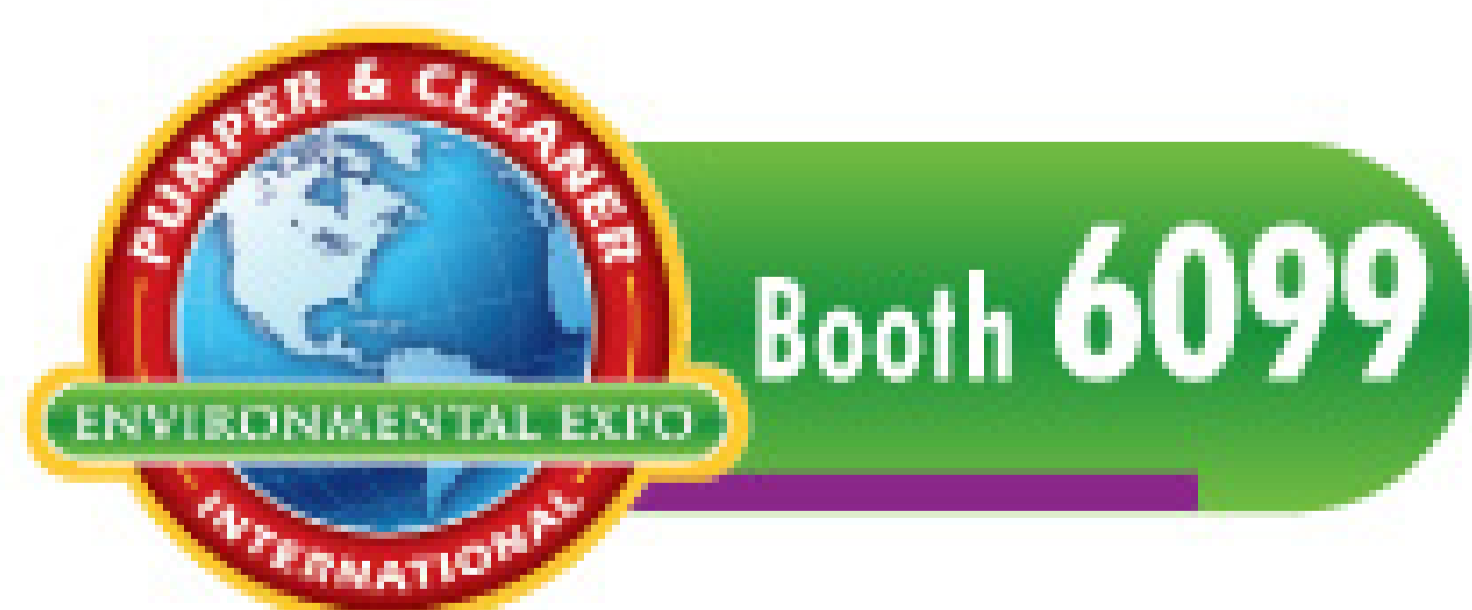

Ask for a quality Moro pump from your truck builder, or call us for the dealer nearest you.

moro PUMPS Pittsburgh, PA | 1-800-383-6304 | fax 412-269-4172
 www.morousaeast.com | moroeast@attglobal.net
 St. Louis, MO | 1-866-383-6304, 636.584.8844
 fax 636-583-2044 | www.morousaeast.com | moro@charter.net

MAX-LIFE Manhole Tools

Debris Catchers

Use Debris Catchers with Jet instead of Combo. Ideal where small amounts of debris are expected. Standard **MDC-6** model Comes with 20' of Poly Rope. Available from 6" to 24".

Grit Catchers

MDC-6CW are similar but have half moon bottom around sides and back to stop liner grit and black sand from flowing through. Fills with material faster.

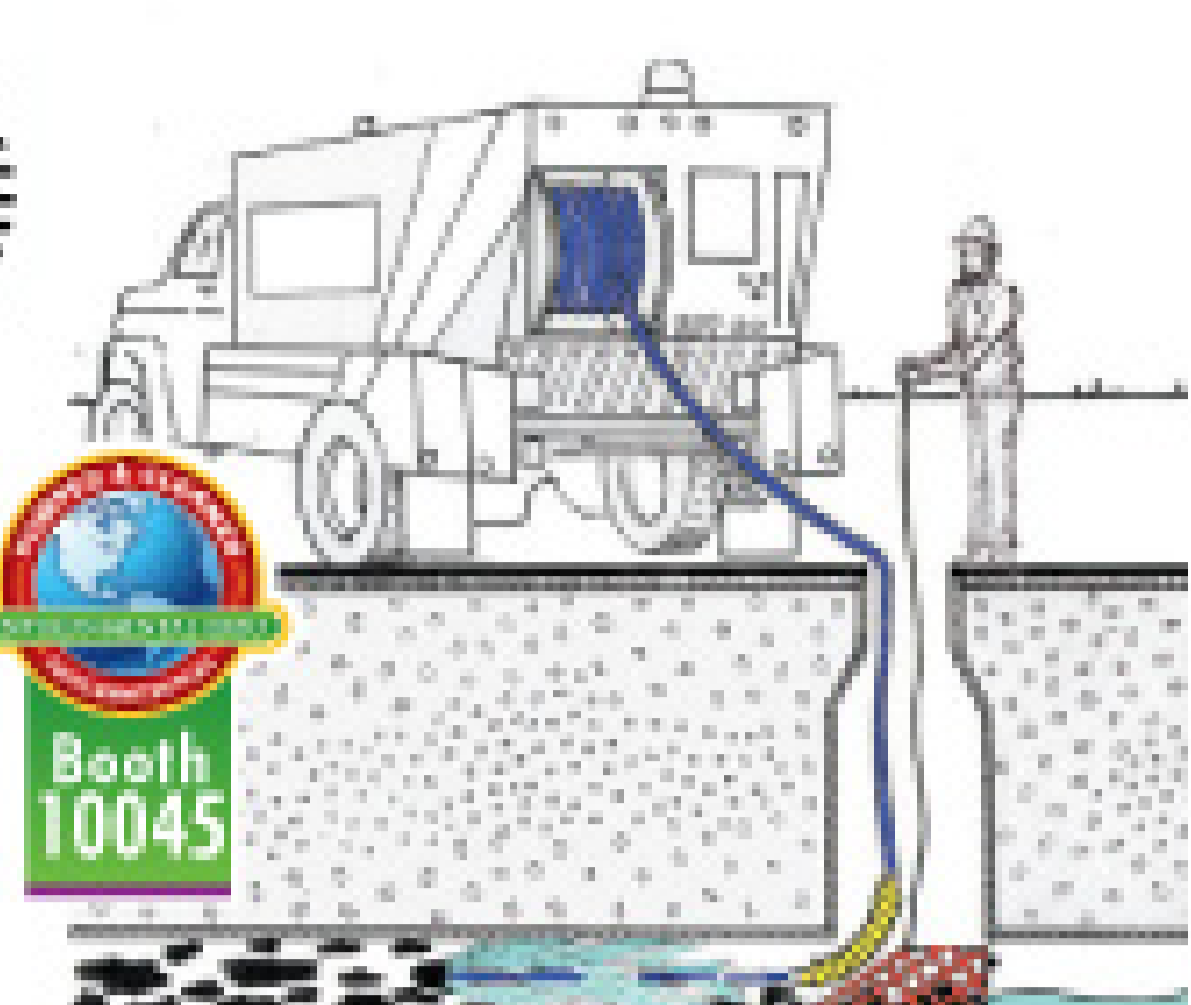
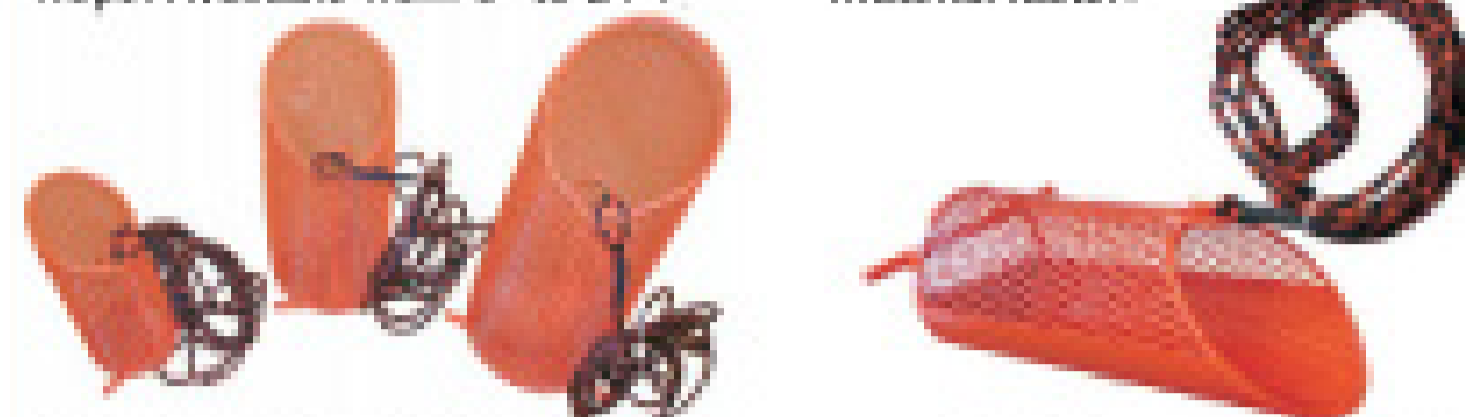

Booth 10045

MPF-24 Quick Connect Fiberglass Poles

24' pole set used with above Tools and Debris Catchers. Each set Includes 3 ea. 6' male x female and 1 x 6' end pole. These are Light, Strong durable poles with positive lock Aluminum quick couplings. Other lengths available. Use with Debris and Grit Catchers and assortment of tools below



- MGLC-1** Grease Log Chopper. Blade cuts thru heavy pieces.
- M3PG-1** Three Prong Grabber. Great for Rocks and Roots.
- MHG-2** Horse-Shoe Grabber. Great guiding hose in and out of sewer lines.
- MDS-6** Debris Scoopers Heavy duty construction For 6", 8" and 10" Pipe sizes.
- MCG-6** Grit Basket. For use with poles or rope. In sizes from 6" to 24".

Debris Catchers and Grit Catchers both can be used with any length of Fiberglass Poles. Provides for positive action of positioning, raising and/or lowering these catchers in manholes.

MCLAW MAX-CLAW 7'-15' Telescopic Extendable Claw with fiberglass pole extensionspring loaded end Claw for Heavy duty retrieval. Jaws stay open and positive rope pull locking systems assure you won't loose your debris.

MDG-1 DEBRIS GRABBER 5'-15' Telescopic Extendable Debris Grabber with Steel body construction and articulating end fork. Rope opens and closes jaws for positive grabbing.

Versi-Clam. Knock down design, easily assembled from 6" to 25". One size can be used in different lengths. Ships via UPS. Now you don't have to pay those high trucking charges

MAX-LIFE MANUFACTURING CORP.
 COMPLETE LINE OF SEWER RODDING TOOLS AND EQUIPMENT
 FAX: (714) 897-2810 www.flexmax.com dhp@flexmax.com 888-873-6295

The COMPLETE CCTV Sewer Inspection System from CYCLOPS ELECTRONICS

The **CYCLOPS** Vehicle Mounted Color TV System comes with choice of color camera and transporter.

The Economical **Valu-Pac** Color System is easily rolled on its own wheels and transported by pickup or van.

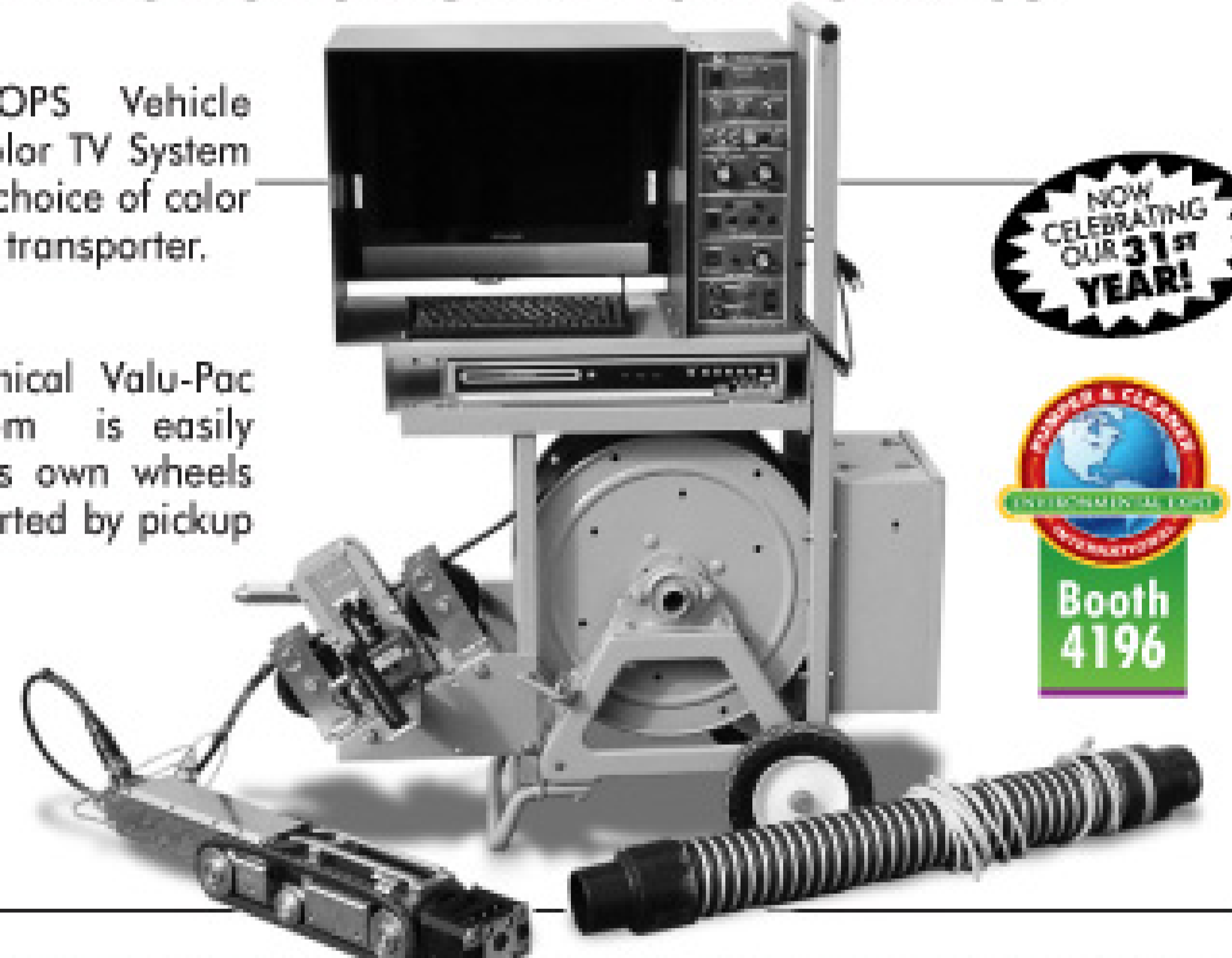

NOW CELEBRATING OUR 31st YEAR!

Booth 4196

PORTABLE OR MOUNTED ON YOUR CHOICE OF VEHICLE

CYCLOPS ELECTRONICS, INC. Manufacturer of Quality Sewer TV Systems Since 1978
 "Known for Prompt Service!"

123 Commerce Ave. | Boerne, TX 78006 | Phone: 830-249-9756
 Fax: 830-249-8535 | E-mail: cyclopsz@beecreek.net | www.cyclopsz.com

DEALERSHIPS AVAILABLE IN SOME AREAS



There's a reason they call us Mr.™
What do they call you?

Customers know it's easy to spot a Mr. Rooter®, and not just because of the bright, red van he drives. It's how he does his job. A Mr. Rooter® franchise gives you exclusive territory, brand identity, marketing support, established business systems and more. Find out why we're the ultimate service franchise opportunity. There's a reason they call us Mr.™

800-298-6855

MrRooter.com/franchising

Mr. Rooter™
PLUMBING



On closer inspection...
...Pearpoint has the answer!



Whatever the need, whatever the environment ... with Pearpoint equipment you can provide the highest quality remote TV inspection, carefully and quickly with minimal cost.

With low cost, rugged push rod units and sophisticated, highly maneuverable tractor systems all complemented with the very best lighting and camera technology.

From simple, out-of-the box domestic investigations, to close examination of hundreds of meters of mainline pipework – all with the ability to offer high quality video recording and digital onsite reporting.

Pearpoint also offers advanced explosion proof systems that operate in Zones 2,1 and 0 hazardous environments utilising rod and cable designed to operate in the most difficult of conditions.

- Push Rod Systems starting from \$5,665
- Tractor systems starting from \$29,000
- Van and inspection systems from \$66,000

To find out more call us Toll Free (800)-688-8094 ext 245 or visit www.radiodetection.com/drain

Pearpoint 72055 Corporate Way, Thousand Palms, CA 92276, USA

Copyright 2009 Pearpoint Ltd. / Radiodetection Ltd – SPX Corporation. All rights reserved. Radiodetection is a subsidiary of SPX Corporation. SPX and Radiodetection are registered trademarks of SPX Corporation. Due to a policy of continued development, we reserve the right to alter or amend any published specification without notice.

Your customers request the
BEST,
so should YOU.

PROVAG
Condor
INDUSTRIAL PUMPOUT STATION



Ideal for Grease Traps
Pumps 60gpm
55 gallon capacity
Will NOT blow 15 amp breakers
Odor control technology

Thank you for visiting our booth in
Louisville!!

Westmoor, Ltd appreciates your business
and we look forward to serving you for
another 70 yrs!!

Westmoor, Ltd

www.westmoorltd.com pumps@westmoorltd.com

800-367-0972

CONSERVATION EVERYBODY'S RESPONSIBILITY

*Proven for
over 20 Yrs.*



*Made in
the USA!*



**LET A COMPANY WITH 20 YEARS
INSTALLATION EXPERIENCE TEACH YOU
THE ENVIRONMENTALLY SAFE WAY**

Lateral Lining



Epoxy Coatings



NO VOC'S

NO ODORS

NO STYRENE

NO LEACHING

Sectional



MH to MH Liner



STEPHEN'S TECHNOLOGIES

1-888-S-T-E-P-H-E-N or (863) 438-8783 Fax (863) 439-3755



3 NEW vCam Digital Systems

Digital Command Module with Video digital recorder (60GB hard drive)
 Crystal Clear "8" TFT LCD display
 Three reel types, all work with Digital Command Module

- Mini reel "M" Type
- Standard reel "C" Type
- Large reel "P" Type

USB interface to transfer video
 Full function keyboard and titler
 Powered by internal rechargeable batteries, mains or 12v dc (car power)
 Locatable Color Self Leveling Cameras
 vCam Loc, a full function locator with color display



Vivax Corp
 23-27 Bland Street Emerson, NJ 07630
 TEL 201 265-5502
WWW.Vivax.biz

CHECK OUT THE TOUGHEST HOSE IN THE SEWER CLEANING INDUSTRY

ARMOR BELT

EXTREMELY DURABLE, LIGHTWEIGHT, AND HIGHLY ABRASIVE RESISTANT. THIS HOSE IS PERFECT FOR THE TOUGHEST OF SEWERS. EMAIL OR CALL US TODAY FOR SAMPLES!



HOSE PRODUCTS, INC.

YOU KNOW IT'S THE BEST

sales@piranhahose.com **1-800-250-5132**

ARMOR BELT IS AVAILABLE IN 2500 PSI, 3000 PSI, AND 4000 PSI
 CHECK OUT THE SPECS AT WWW.PIRANHAHOSE.COM

LAPLACE EQUIPMENT

RENTALS, SALES & SERVICE

- **WATERBLASTERS:** PRESSURE TO 40K, FLOW TO 100 GPM
- WATER JETTING TOOLS
- HYDRO-MOWERS
- 3D NOZZLES
- ROTATING NOZZLES
- HIGH PRESSURE HOSES
- LANCES
- FITTINGS
- TIPS
- SUPPLIES
- EXPERIENCED TEAM FOR PLANNING, TRAINING & SETUP



CALL 985.652.5210 FOR YOUR WATERBLAST PROJECT SOLUTIONS
WWW.H2OBLAST.COM

Every Tool You Need

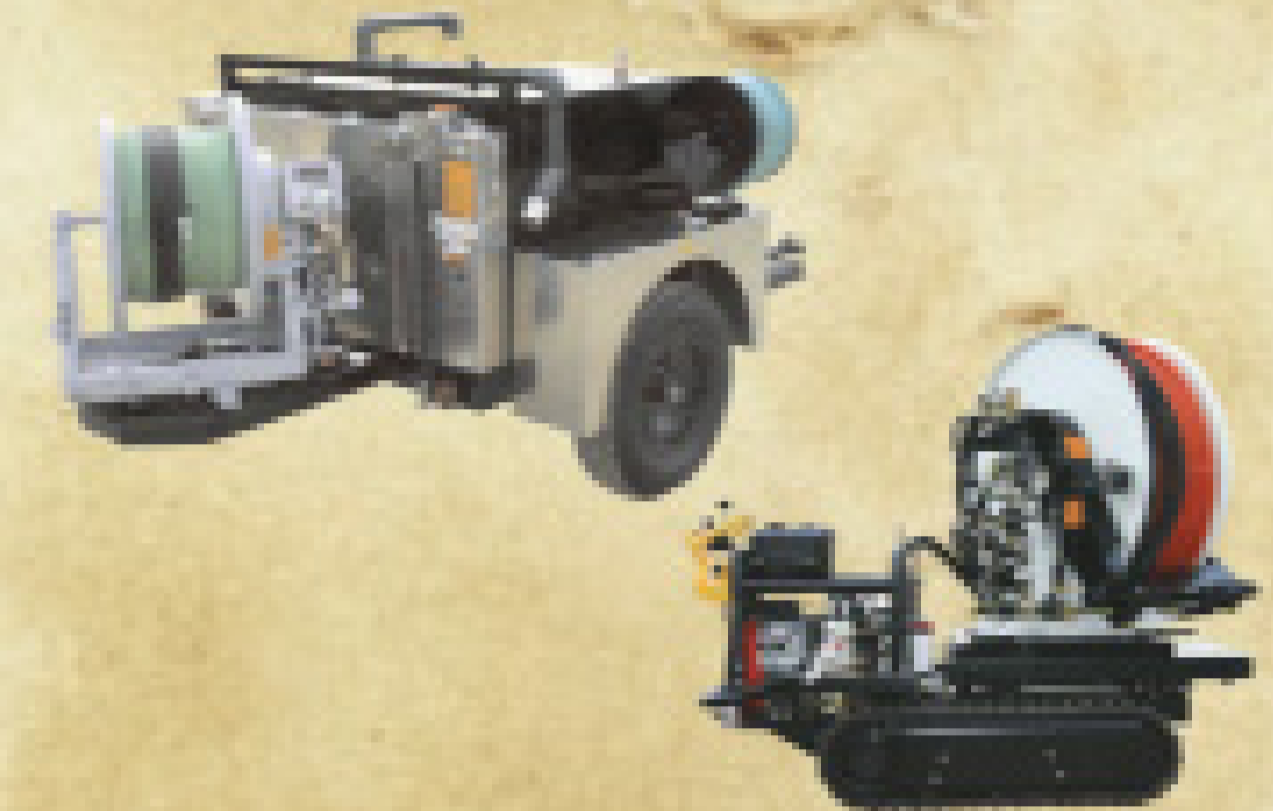

Jack Doheny Supplies has every tool you need to get the job done!

- Representing the best manufacturers in the industry
- Largest Rental Fleet in the United States
- Huge Parts and Accessories Inventory
- Special Financing Programs
- Guaranteed Trade-In Values
- Remanufactured Units with Full Warranties

Visit
our booth at the
Pumper Show
for a chance
to win a
“tricked out”
Tool Box

With Jack Doheny Supplies in your tool box nothing is impossible.

Jack Doheny **Companies**



*“World’s Largest Distributor of Sewer Cleaning,
Air Handling and Street Sweeping Equipment”*

800-336-4369
www.dohenysupplies.com



Giving a Lift

Cranes help technicians move heavy equipment to and from service vans, saving their backs and helping to prevent accidents

By Ken Wysocky

When technicians at Frank Bonetti Plumbing need to take a load off on the job, they head for their Dodge Sprinter service vans. They reach for a rear-mounted, 1,500-

The Vancrane, made by Pickup Equipment Inc., is bolted to the floor and roof and takes up minimal space in the rear corner of the van. Bonetti and his crew installed the cranes on all six of the company's service vans.

MONEY Machines

pound-capacity electric crane that helps them lift equipment. It minimizes equipment damage and keeps

The cranes earn their keep when technicians use the drain cleaners that each truck carries: Models 1065, 300, 100 and 502 from Spartan Tool LLC. The trucks also carry a Gatorcam digital pipe inspection camera, made by WCT Products, and an RD 4000 pipe

MONEY MACHINES

OWNER:	Frank Bonetti Plumbing, Castro Valley, Calif.
FUNCTION:	Drain cleaning and plumbing
VEHICLE TYPE:	Dodge Sprinter van
PRIMARY EQUIPMENT:	Four drain machines (Spartan Tool LLC), Gatorcam inspection system (WCT Products), RD 4000 locator (Radiodetection/SPX).
COST:	\$46,000

the spring in the technicians' steps, says co-owner Dan Bonetti.

"The cranes lift our heavy sewer machines in and out of the vans," says Bonetti, whose company is in Castro Valley, Calif. "We've even used one to reset a fire hydrant.

"We had ramps for a while, but they weren't built in, so they always seemed to be in the way. Plus, even with a ramp, you still have to wheel the machine up or down, which makes you prone to injuries. Our workmen's compensation insurance rates never go down, but the crane helps to keep them from going up even higher."



To prevent equipment damage and employee injuries, Frank Bonetti Plumbing of Castro Valley, Calif., has outfitted its service vans with the Vancrane, a rear-mounted, 1,500-pound-capacity electric crane made by Pickup Equipment Inc. (Photos courtesy of Frank Bonetti Plumbing)





MAKING WAVES

Dan Bonetti wanted to make a splash with a white 2007 Chevrolet Colorado pickup truck. The result is a vehicle that makes waves wherever it goes. Hand-painted waves that adorn the front of the truck.

"Everyone seems to put flames on trucks, but since we're in the plumbing business, we decided to use water," Bonetti says. Whether it's parked at a jobsite or on a golf hole sponsored by the company at a charity outing, the truck and its \$5,000 paint job draw admiring glances.

"When people find out it's not a vinyl wrap, they always step in for a closer look," Bonetti says. "They say they've never seen a plumbing truck like this before. It's pretty cool."

MORE INFO:

Adrian Steel Co.
800/677-2726
www.adriansteel.com

General Pipe Cleaners
800/245-6200
www.drainbrain.com

Pickup Equipment Inc.
800/382-6680
www.pickupequipment.com

Radiodetection/SPX
877/247-3797
www.radiodetection.com

Spartan Tool LLC
800/435-3866
www.spartantool.com

WCT Products
800/928-7763
www.wctproducts.com

SHOW US THE MONEY (MACHINE)

Money Machines, a new feature in *Cleaner*, reports on innovative work vehicles that help contractors operate more efficiently, satisfy customers and earn more profit. We'd like to know about your Money Machine — be it a service van, camera truck, jetting rig, vacuum unit or any vehicle that really helps drive your business. To nominate your vehicle for a feature in this column, send an e-mail to editor@cleaner.com. Tell us briefly but specifically what features make it a great producer. And send a picture — because appearance counts. We look forward to seeing your Money Machine.

State-of-the-Art Technology

THE NAME... THE QUALITY...
...THE WORLD RECOGNIZES.

URACA

Complete Line of High Pressure Plunger Pumps

The "Versatile" KD-708

Pressures up to 5800 psi >
Flows up to 80 gpm >

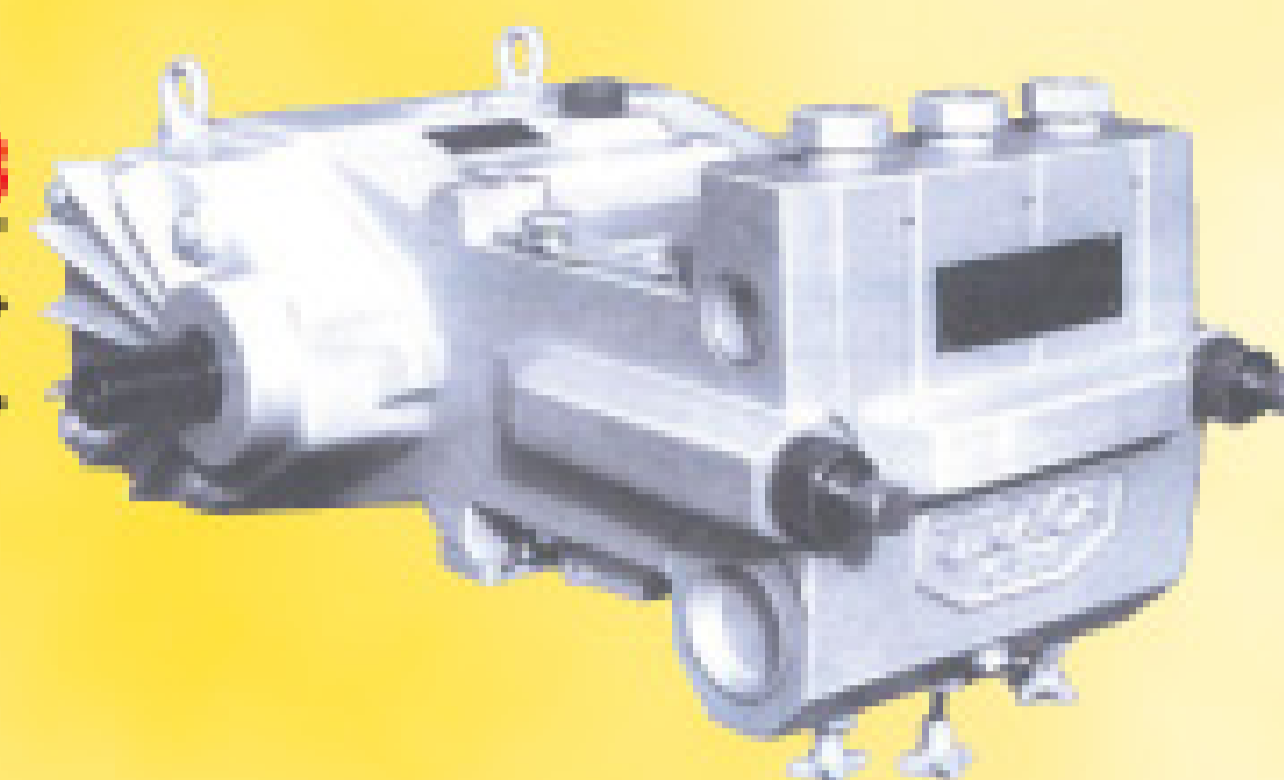

The "Innovative" P3-45

< Pressures up to 3625 psi
< Flows up to 125 gpm

The "Supreme" KD-724

Pressures up to 5800 psi >
Flows up to 160 gpm >



Our complete line of vertical pumps are ideal for restricted space applications.



The "Legendary" KD-716

< Pressures up to 7685 psi
< Flows up to 103 gpm

The "Little Titans" P3-08 & P3-10

Pressures up to 3625 psi >
Flows up to 45 gpm >

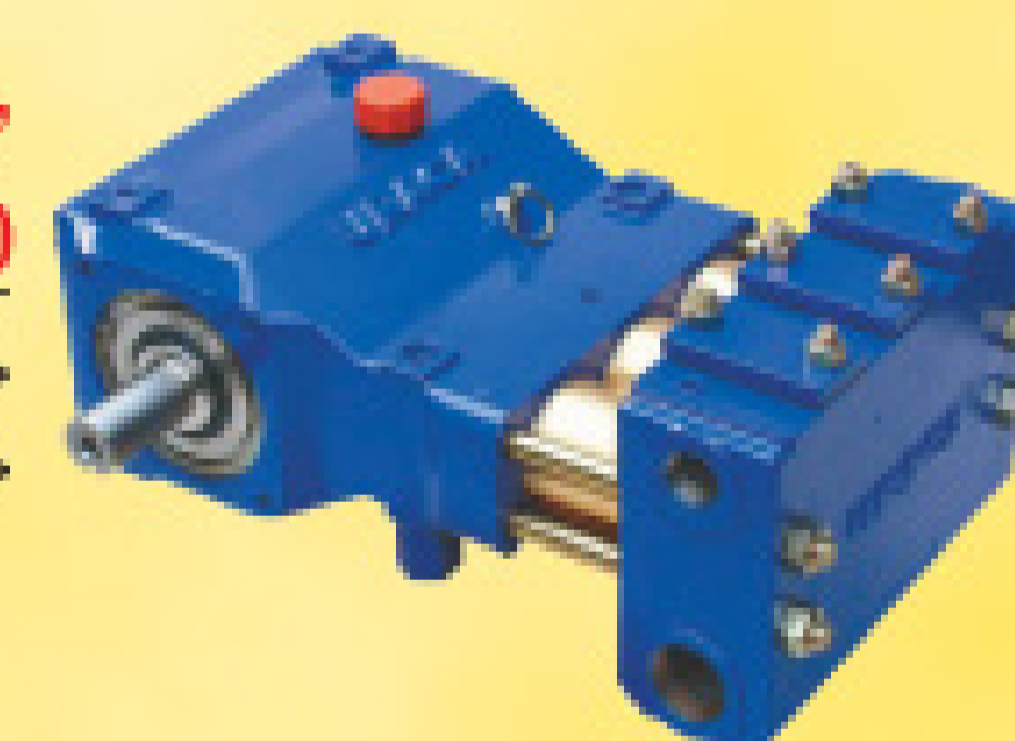

URACA lets you inherit a reputation of distinction with a history of over 100 years.



System Design & Complete Line of Accessories:

Nozzles, Spray Guns, Hose Assemblies, Ball Valves, Unloader & Safety Valves

phone 330.405.7300 | fax 330.405.7301 | e-mail worldtech@worldtechindustries.com
World-Tech Industries: World Technologies @ Your Reach.™

RHINO

“JAKE”

Manhole Cover Extractor

8 lb



- 8 lb. and 12 lb. (4140) ASTM A148 cast steel head breaks frozen covers free easily. Serrated edge strengthens pick-end and eliminates possibility of tool becoming bottlenecked in the cover.
- Combination sledge hammer and pick/pry bar. Two tools in one enables a worker to carry only one piece of equipment into the street
- Tapered saw-tooth pick fits 5/8" or larger drain holes and most pick slots.
- Top quality handle constructed of fiberglass.
- "Mary A" is patented, patent pending on the "Jake"



12 lb



“MARY A”

Manhole Cover Extractor

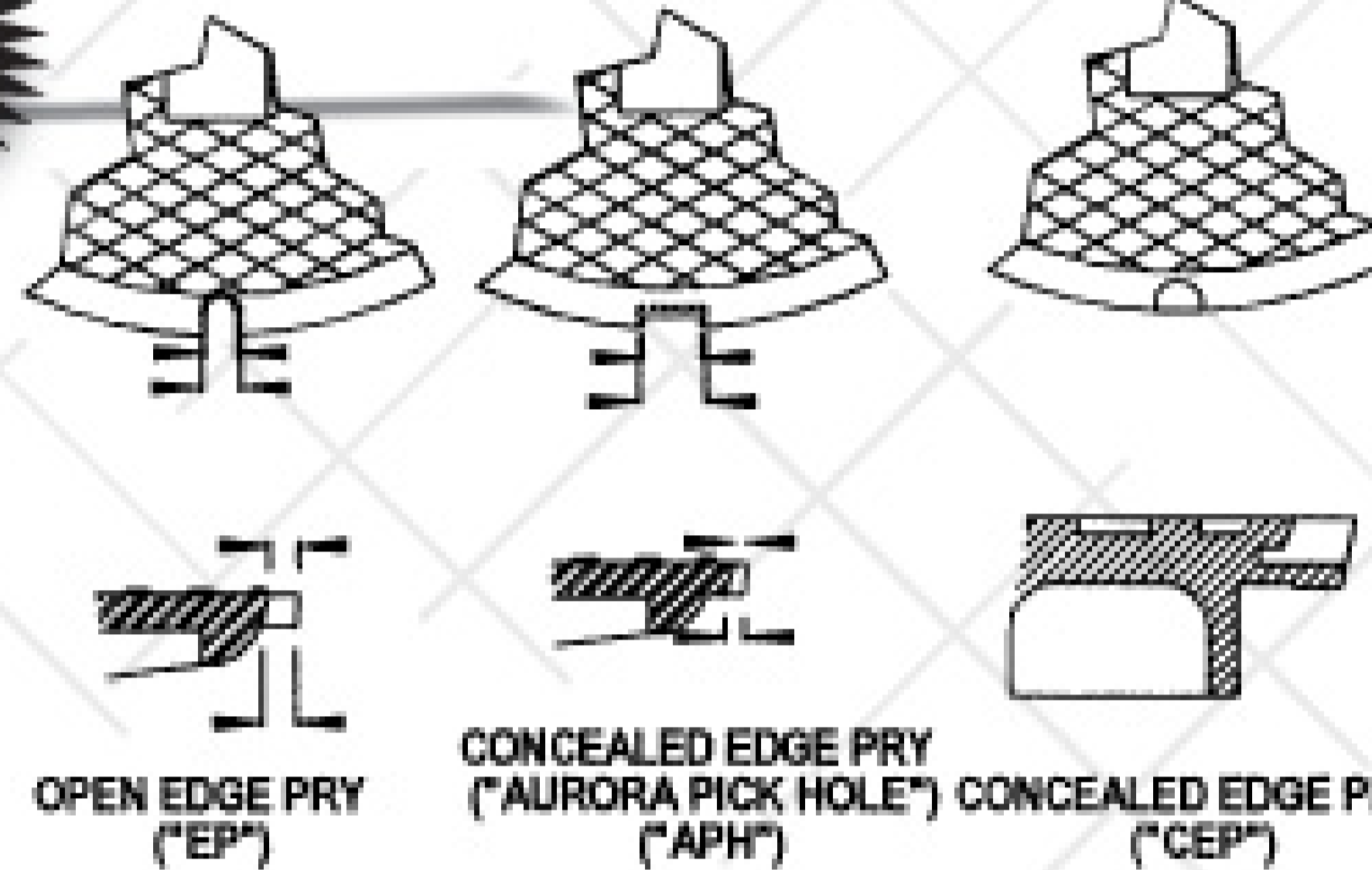

Distributed by:
DOUG MEADOWS COMPANY, LLC
1.800.588.3684
 Fax (325) 695-7954

Web site: www.dougmeadows.com



Paikert™



NozzTeq®

Taking Science to the Sewer!®

Equipment Engineered for Long Lasting Performance.™



Rental & Leasing Services Available!
 Call For FREE DVD

Phone: 1.866.620.5915 Fax: 603.413.6744

www.nozzteq.com

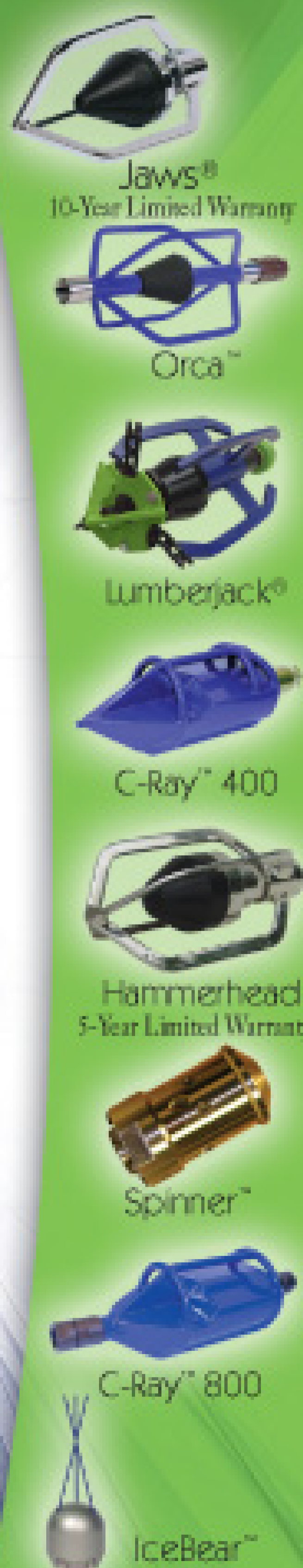

FSI FLUID SYSTEMS, INC.

Specializing in Parts & Service for High Pressure Water Pumps
 Used on Sewer & Catch Basin Cleaning Units



PARTS FOR PISTON & PLUNGER POWER PUMPS
 INQUIRE ABOUT PUMP TRADE-IN PROGRAM
 SHOP OR FIELD SERVICE

1-800-880-5800



FAX: 812-428-7061

E-MAIL: don@fluidsystems.net • WEB SITE: www.fluidsystems.net



innovative solutions for infrastructure management

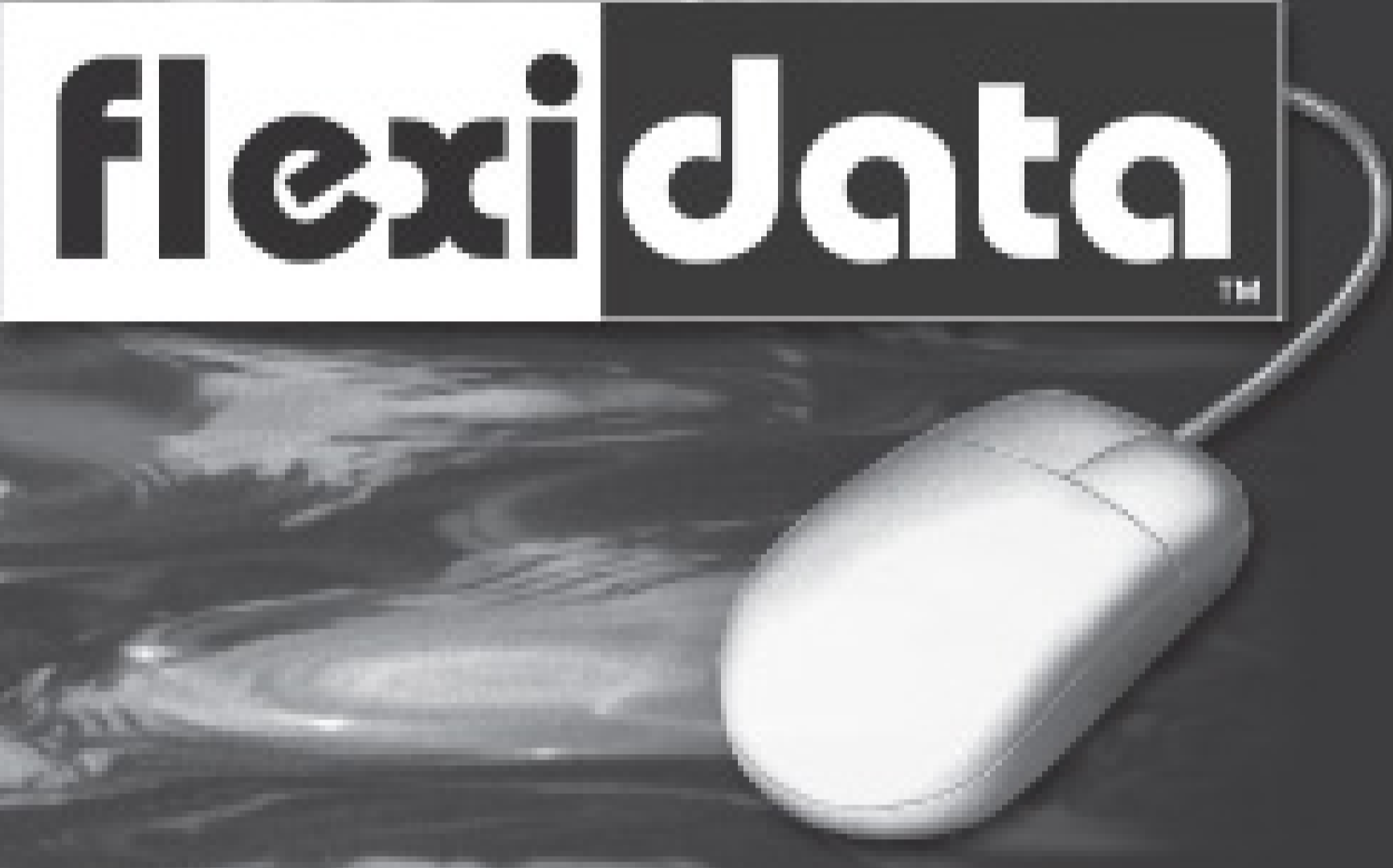

Presents THE **TRIPLE CROWN** of Pipe Survey Solutions

CAPTURE. ANALYZE. COLLABORATE.

- Business Partners: Hansen/Neztek, GBA Master Series, ESRI and Azteca Cityworks
- GIS tools to import, insert, filter survey results and identify pipes
- PACP, MACP, and WRc standards built-in
- Powerful analysis tools to help you prioritize and manage your assets more efficiently
- Multiple modules to extend the power of your data



The MODULES

GIS

flexidata™ and its GIS Tools let you export survey conditions to a geodatabase or shape file so you can display conditions where they exist, view them and make decisions.

Manhole

Know, understand and maintain the vital entry points of your infrastructure systems. Collect, analyze and share data about manhole components per the MACP (NASSCO Manhole Assessment Certification Program) format.



The latest in our powerful line of add-ons interfaces with the revolutionary IBAK Panoramo and Panoramo SI technology to create survey data files for measuring, analyzing, capturing pictures and generating detailed reports.



PACP SURVEY SOFTWARE

- A built-in wizard to guide the user through the required fields and survey process to eliminate the guesswork
- Create data CDs and DVDs within the program to share your movies, pictures and reports without any installation of third party program
- This Xtremely fast, simple and affordable solution is an excellent choice for those new to pipe survey reporting and data collection

Call today for more information or visit us at the Expo for a live demonstration.

PipeLogix, Inc.® | 866.299.3150 | info@pipelogix.com
www.flexi-data.com | www.munixs.com

Expo Booth #158



Trademarks provided under license from ESRI.



OVERLAND
TANK LINE

RUSH  **SALES** 



ALUMINUM TRANSPORT TRAILERS



350 CFM STEAM UNITS

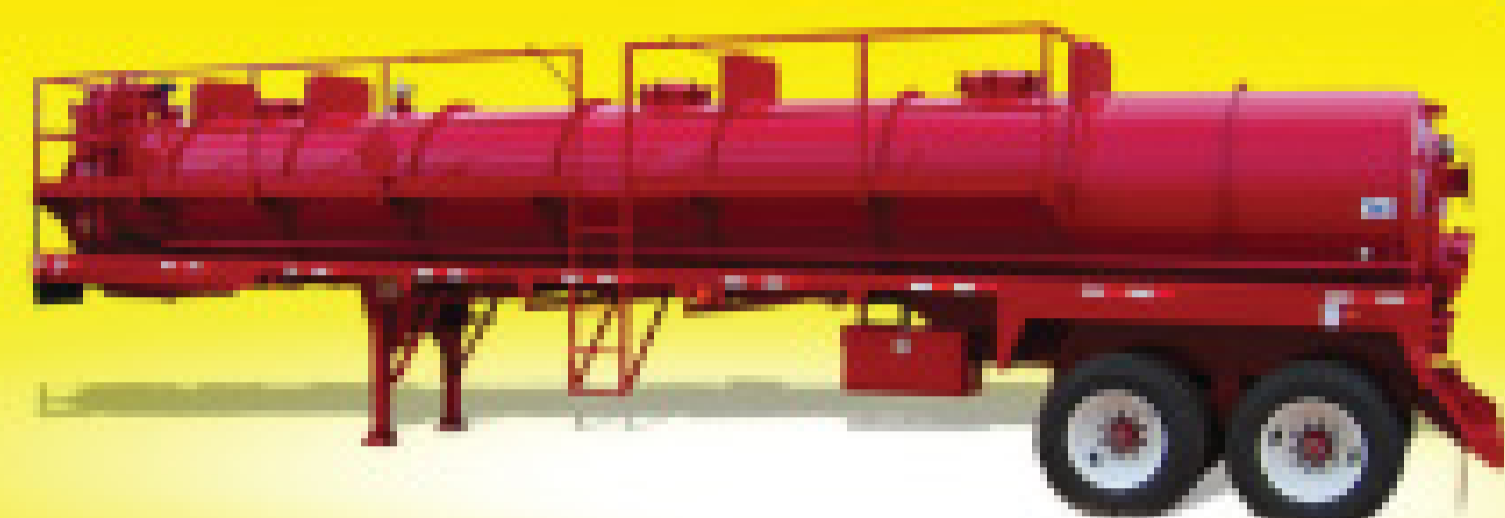

ASME CODE VACUUM TRAILERS

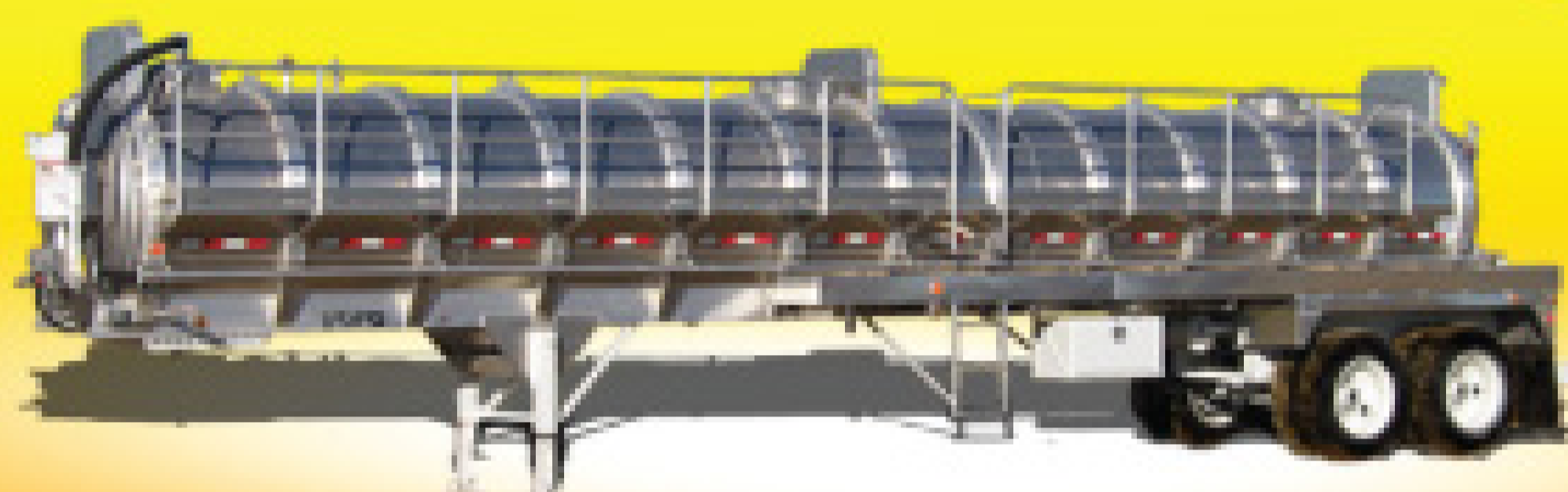

ALUMINUM VACUUM TRAILERS



INVERSION UNIT

4725 FM 18 ABILENE, TEXAS 79602 WWW.OVERLANDTANK.COM TOLL FREE: 866.635.7132

2709 EAST I-20 ODESSA, TEXAS 79766 WWW.RUSHSALES.COM TOLL FREE: 800.489.2397

Introducing a root killer that actually Kills Roots.

When did you **NOT** find roots in older laterals?

It's a tremendous market, but you need more than just good advertising to do the job. You need a product that works time after time and is proven effective in numerous studies.

Exciting news! Vaporooter® the leading name in municipal root control, has contracted Hydro Products Corp. to release their EPA registered product to residential service companies. For a limited time, Hydro Products Corp., is offering exclusive US territories on a first come basis for qualifying companies. Here is how it benefits you:

- ◆ Huge Income Potential
- ◆ Exclusive Territory
- ◆ Proprietary Equipment
- ◆ Full Training
- ◆ Marketing Assistance
- ◆ Repeat business
- ◆ Light weight equipment
- ◆ Years of Municipal Success

Call: 800-781-3164

"So tough, you have to be licensed to kill!"™



Check with us for show specials!

This Is The Nozzle You've Been Waiting For

Patented
Root Rat

MADE IN THE USA

root cutter nozzle



1/2" 7-35 gpm/1500-10,000 psi



3/4-1" 40-160 gpm/1500-4000 psi

"The Root Rat is the easiest and most versatile root cutter nozzle I have ever used. The Root Rat works where other nozzles fail."
Tim Jones, owner of Eastern Sewer Jetting



3/8" 3-10 gpm/2000-7500 psi



Chempure's Hot Box

This Hot Box turns a cold water jetter into a hot water jetter to de-ice, to dissolve grease, etc. depending on the flow rate it can heat the water up to 185° F.

WE SELL AND SERVICE COLD WATER JETTERS

We Sell Parts, Pumps, Unloaders, Hoses, Jet Tips, etc.

Visa, Mastercard, Discover, AmEx Accepted



Booth 9332



Root Rat Combo Kit

3/4 - 1 inch root rat combo kit. Use a reducer adapter to go from 1 inch to 3/4 inch.



Custom Built Jetters

Hot or cold water jetters from 4gpm at 4000psi to 12gpm at 4000psi, skid or cart frames or small trailer systems.

CHEMPURE PRODUCTS CORP.

1-800-288-7873 • 330.874.4300

www.chempure.com

insight | VISION

PUSH, JET, CRAWL ... WE'VE GOT IT ALL!

Value Quality Versatility

⇒ Push systems
starting under \$4K

⇒ 1-4" Micro-Cam
System

⇒ XPress Push System

⇒ Universal Jet-Cam

⇒ Silver Bullet Crawler

⇒ Muni XS Software

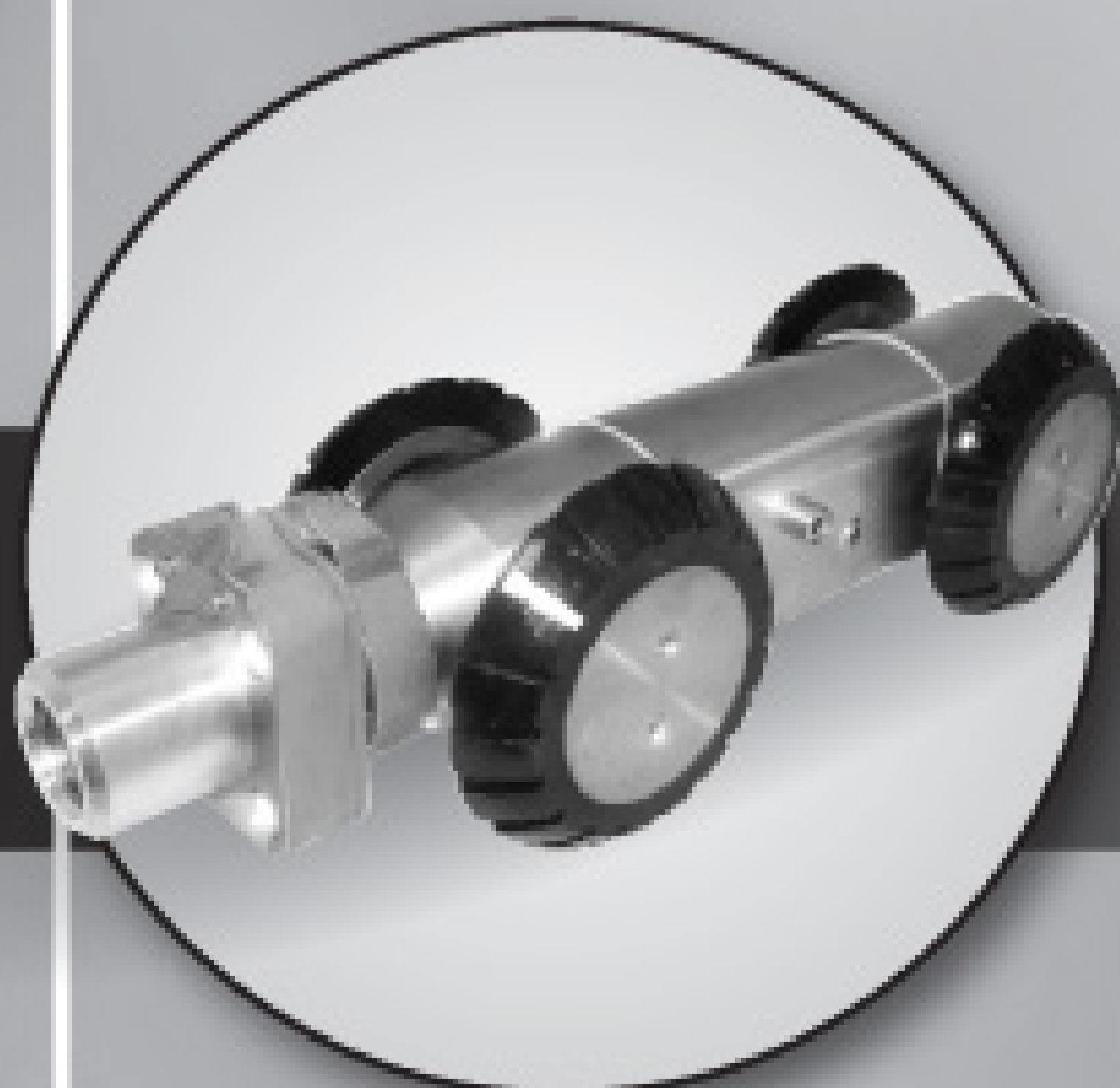

Booth 156

**STOP BY OUR BOOTH
FOR SHOW SPECIALS**

800-488-8177

www.insightvisioncameras.com

Dyna-Vac Equipment

Vacuum Pumping & Sewer Cleaning Equipment

Jet-N-Vac



Booths 7168 & 7169

Dyna-Jet

Experience the Compact Power, Enduring Reliability and Piece of Mind Economy of the Jet-N-Vac Systems. Practical Features make these units Simple, Safe and Reliable while delivering the power for the toughest cleaning jobs

New

SS Drive System..More Power, Less Maintenance, Easier to Operate



On Display at The Louisville Expo Booth #7168



Simple Safe Design
Easy to Operate
Extremely Durable Construction
Many Options Available

DJ18-4000

Also Available as Truck and Skid Mounted Systems

888-298-8668 * 315-865-8084 * www.dynavacequipment.com

Your Source For:

The Best Quality Products & Emerging Technologies



Custom-Designed Service Vehicles



VeriSight Push Camera



Rover



Seek Tech Utility Locator

Rely on us for the best in:

- Water Leak Detectors
- Gas Detectors
- Line Locators
- Fall Protection
- Video Inspection

We Sell The Tools That Work!

Call for more information.

800.992.0222

Order online 24/7 - www.advancedworld.com



DYE TRACERS

Solutions for:

- Infiltration
- Septic Systems
- Cross Connection
- Leaks and more...

BRIGHT DYES

Division of Kingscote Chemicals

www.brightdyes.com | FAX: 937-886-9300

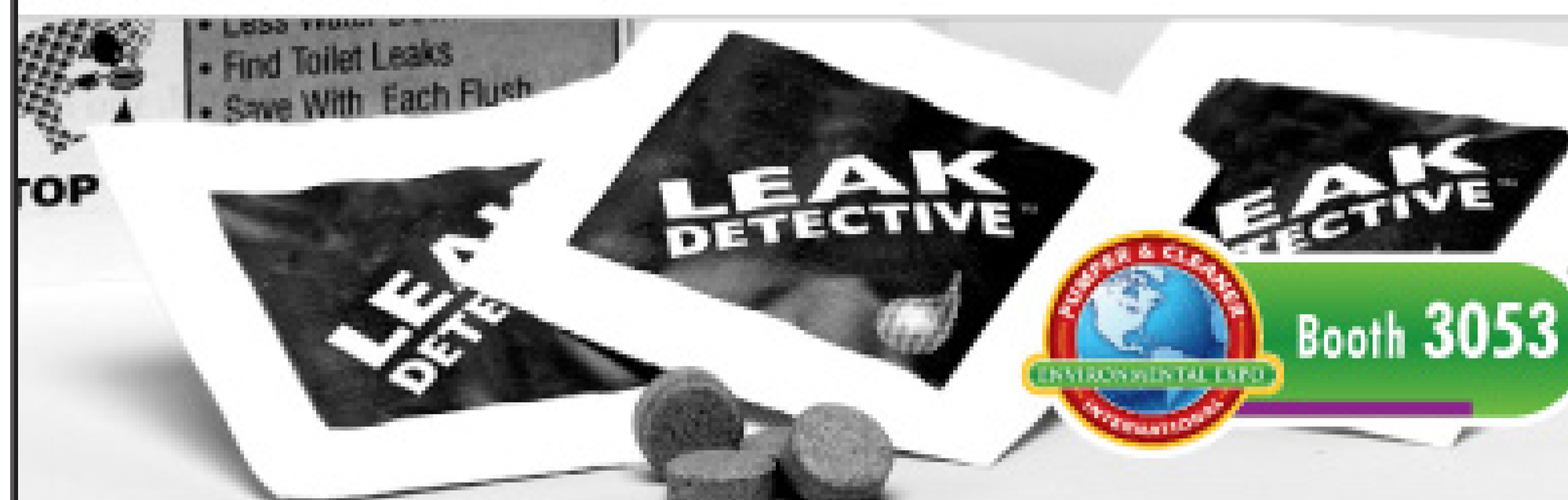

Booth 3053

FREE SAMPLE 1-800-394-0678

YOU CAN INSTALL SEWER and WATER LINES

(WITHOUT DIGGING A TRENCH!)

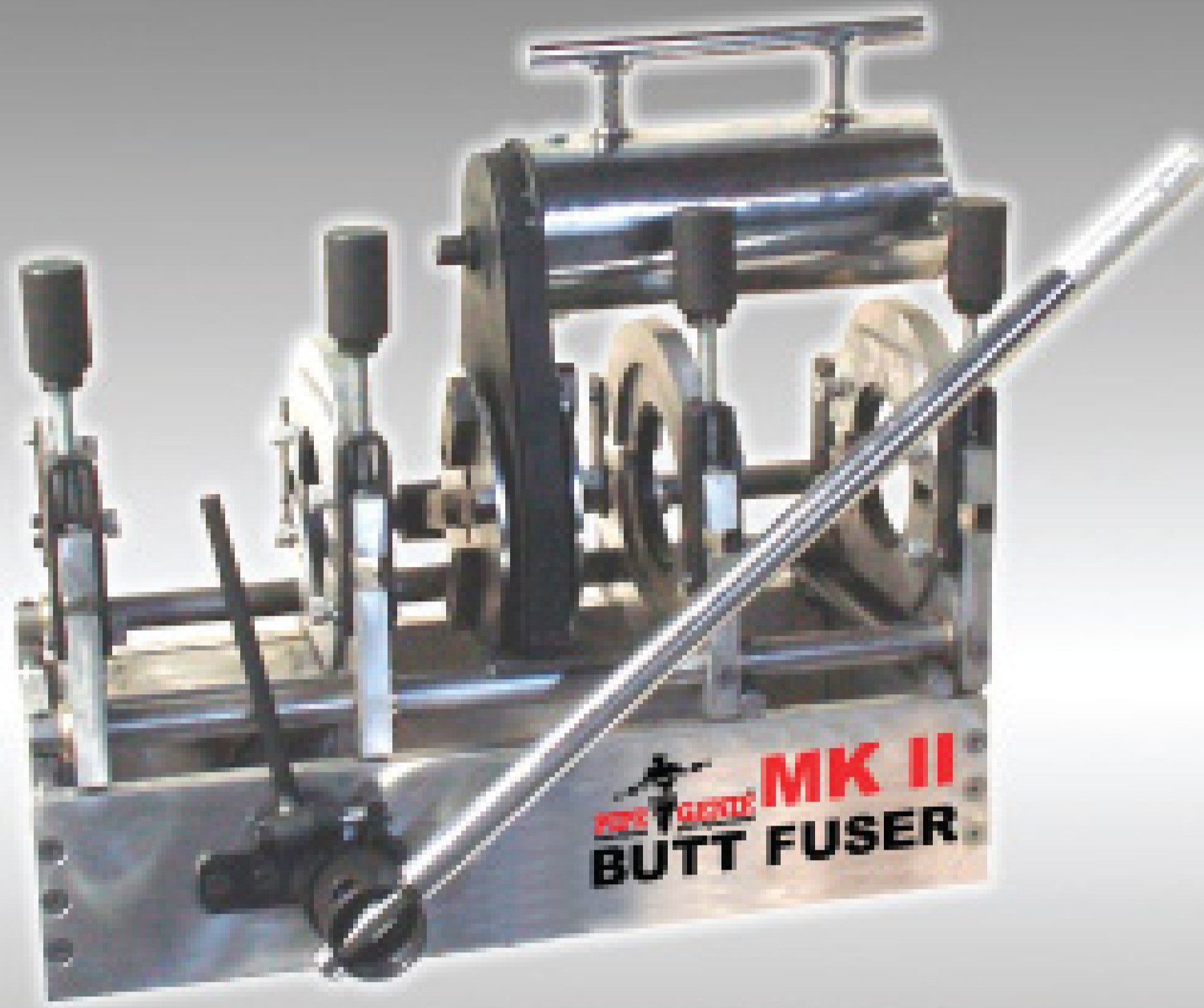

HOT BEAD FUSING 2-8"

Save time with inline fusing as you continuously pull PE pipe!

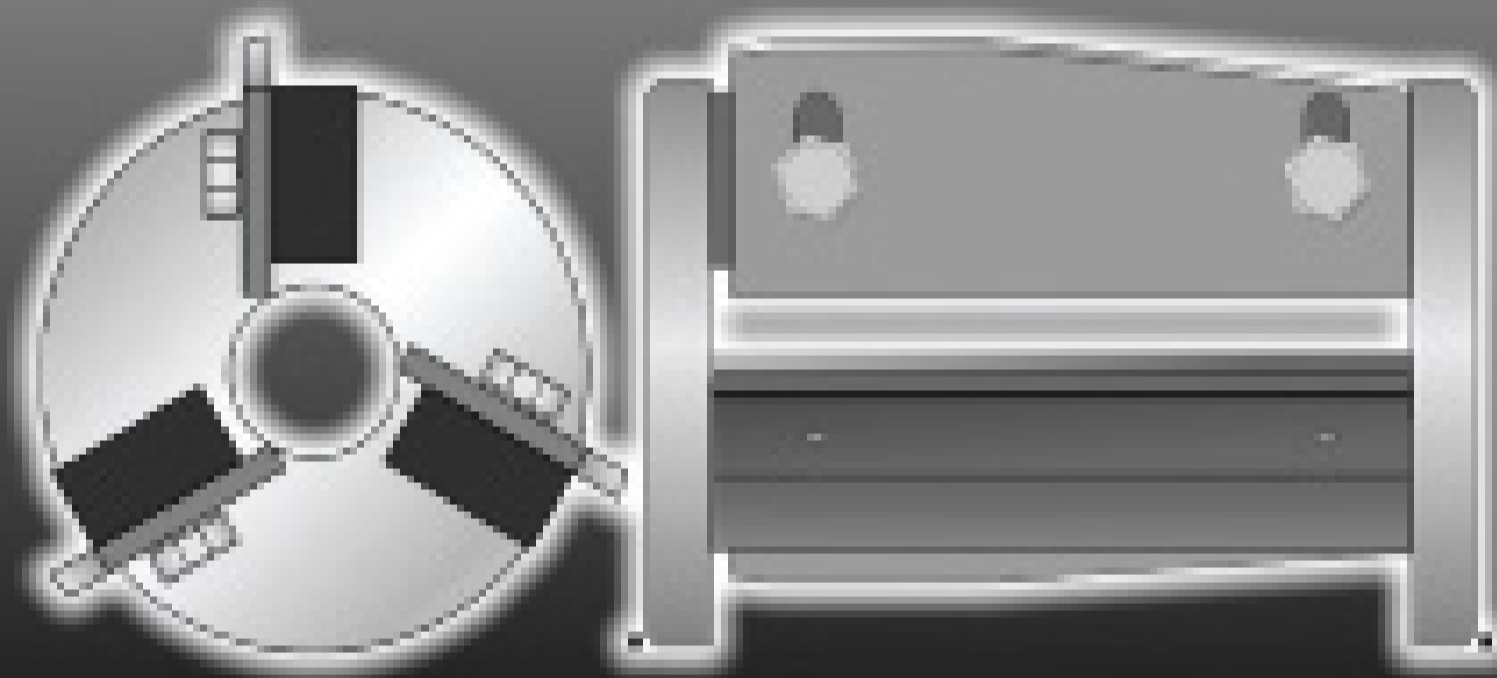

Ream Inner Beads 3 - 16"

Models to accommodate pipe diameters ranging from 4 inches to 20 inches! (24 and 40 foot kits available.)

Pipe Genies Do It All!!

Ductile & Cast Iron, Clay & Concrete, ABS, PE & PVC

Pipe Genies Pull Any Pipe!!

System Power From 20 Tons to 240 Tons!
(Rated for 1/2" - 30" pipe)

Pipe Genies Work Anywhere!!

The Most Compact Systems Available!

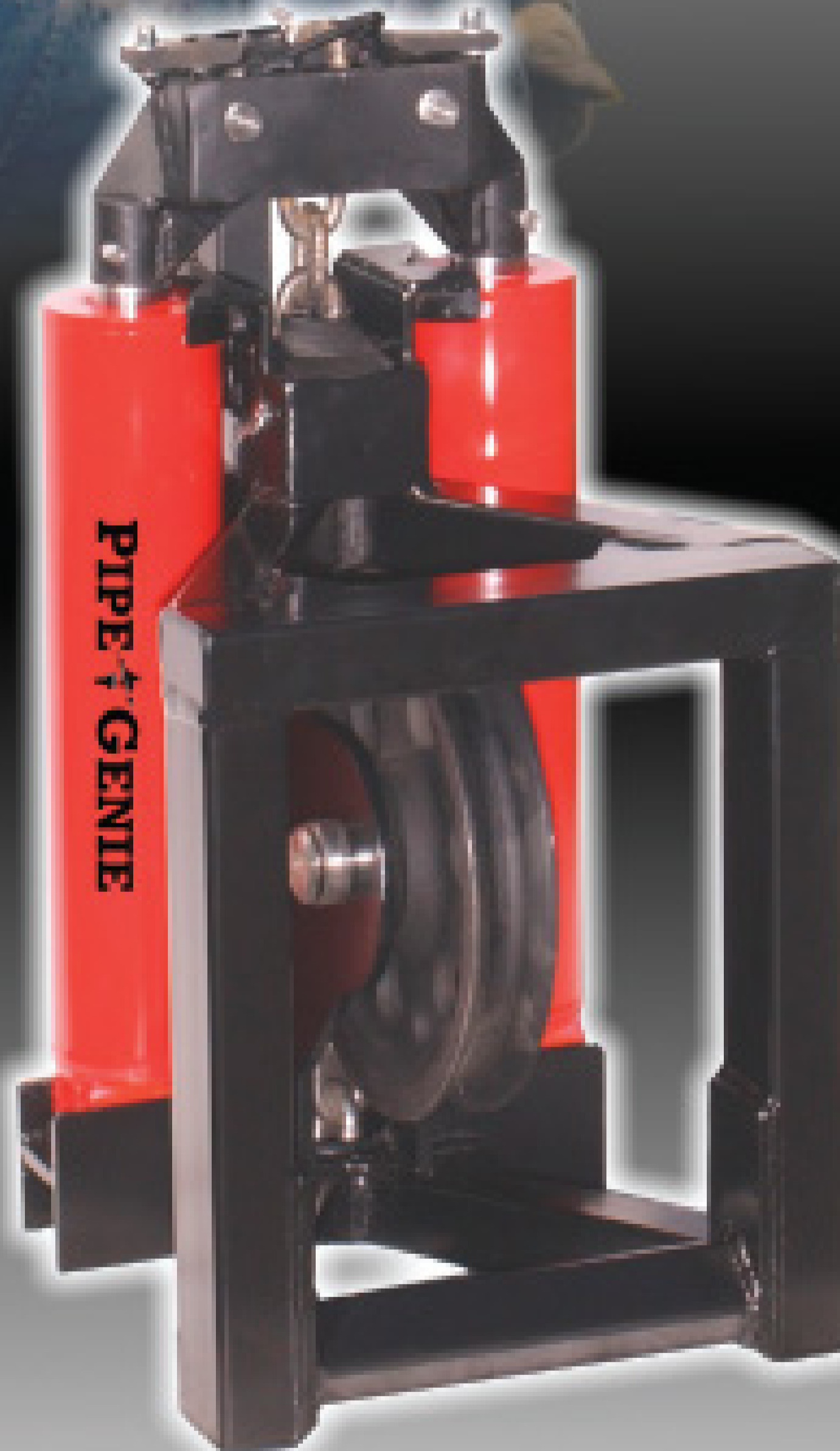

PIPE BURST 1/2 - 30" PIPE

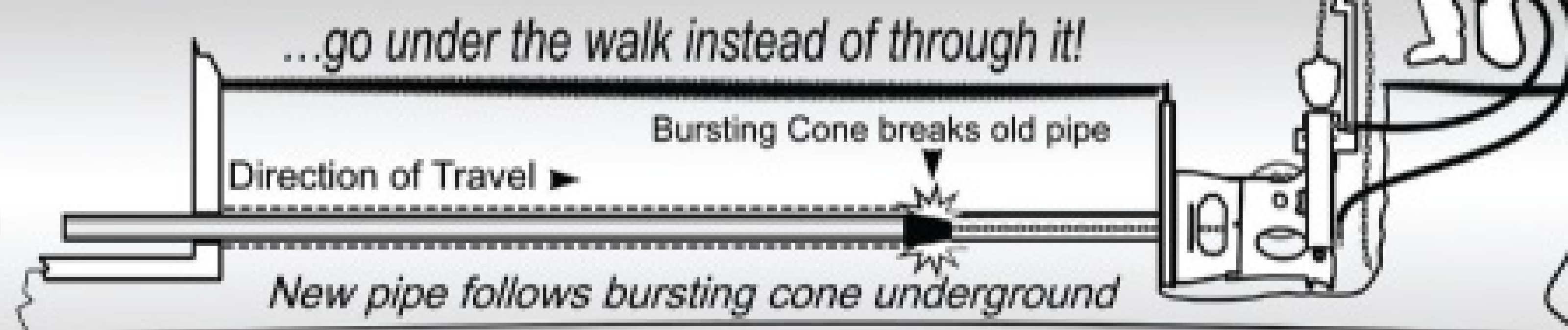

We have everything you need to get started making profits with pipe bursting!



Slice Old Water Pipe

Easily handle those 1" copper pipes with brass fittings, and tricky 1"+ schedule 80 steel gas line pipes!



2-in-1 Convenience Bore then Pull!

Bore through existing lines or create new ones. When complete transform into a hydraulic pulling unit & haul back the new pipe!

Videos Now Online!



Running the Show

The latest versions and tools in business and office productivity software help service businesses stay on top of routing, finance and much more

By **Scottie Dayton**

The bull work gets done in the field, but it takes a strong office to make a contracting business run well. Every year, providers of business and office productivity software upgrade their offerings to help make work life easier and deliver better records, better routing, and generally more efficient operations. Here are the latest offerings from software providers dedicated specifically to the kinds of businesses cleaning and pipe repair contractors operate.

Next Generation

Total Activity Control 2009 from Clear Computing Inc. increases office and route efficiency and lowers operational costs. A drag-and-drop dispatch board lets dispatchers quickly schedule and dispatch jobs onto route or driver calendars. Dispatchers can select and filter jobs to view, and schedule them by date range, rate code and location.

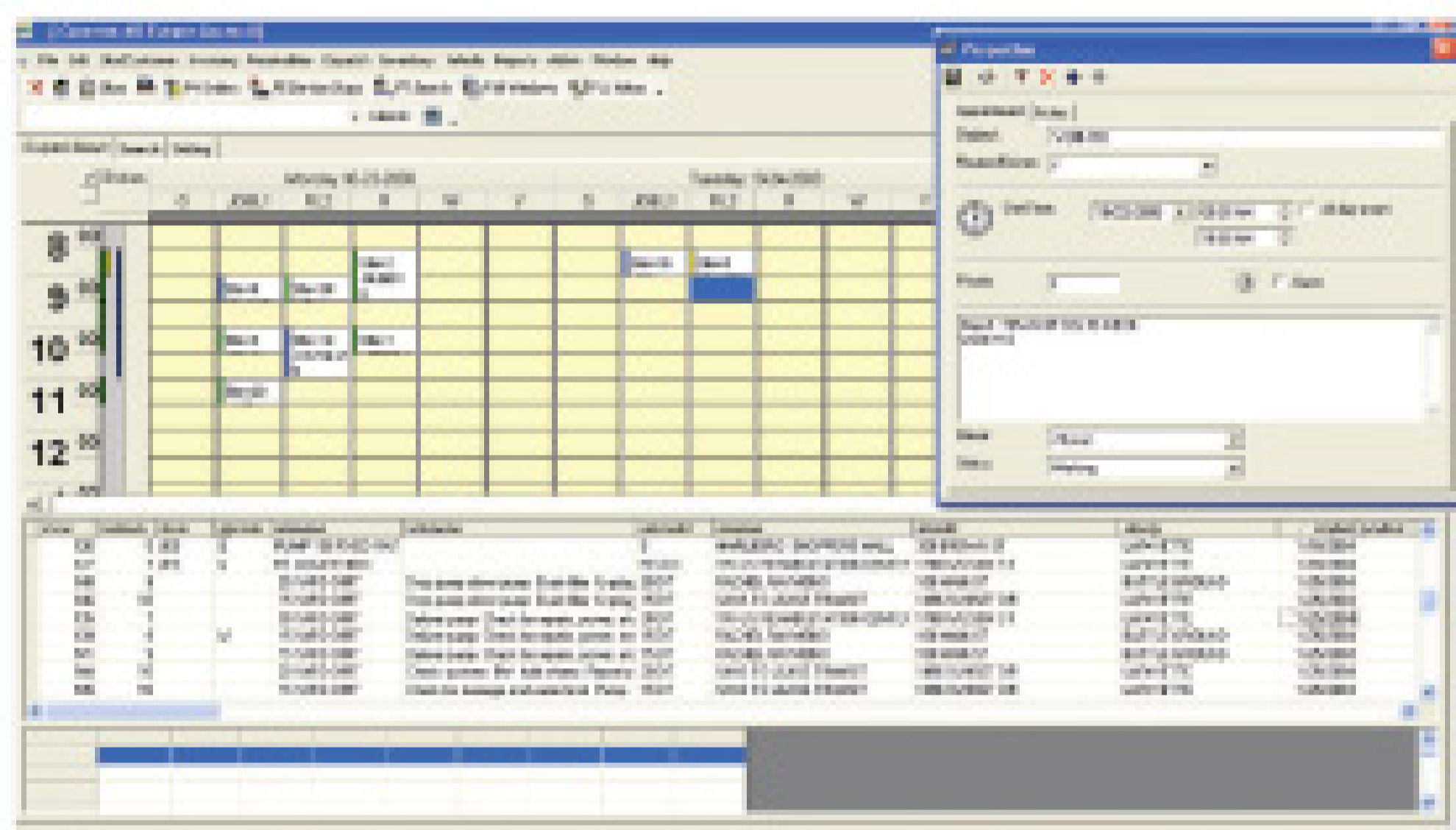

Special tools enable tracking of production by work order, driver, site and market, and scheduling of recurring services. The Standing Orders feature handles accounts done during different days, weeks, months or years. This release has structured query language (SQL) 2005/2008, full audit logs on all transactions, and free integrated Google maps. It also integrates with caller ID and credit card processing.

With StreetEagle GPS and TACTrackerPRO, companies can track vehicles and rental inventory. 888/332-5327; www.clearcomputing.com.

Field Service System

The JaRay Software Inc. field service system from Famhost Hosted Applications manages and schedules preventive maintenance agreements, tracks bids and proposals, handles follow-up calls, and enables users to create lists and mailings from customer and noncustomer residential and commercial databases.

Dispatchers can sort jobs by time promised, job type and customer priority. They can click on a driver ID and sort jobs by proximity or click a job

and show the closest drivers. Live dashboards instantly alert dispatchers when vehicles start up or digital pen images are received. Pop-up calendars enable scheduling ahead, and the job information goes automatically to any cell phone display.

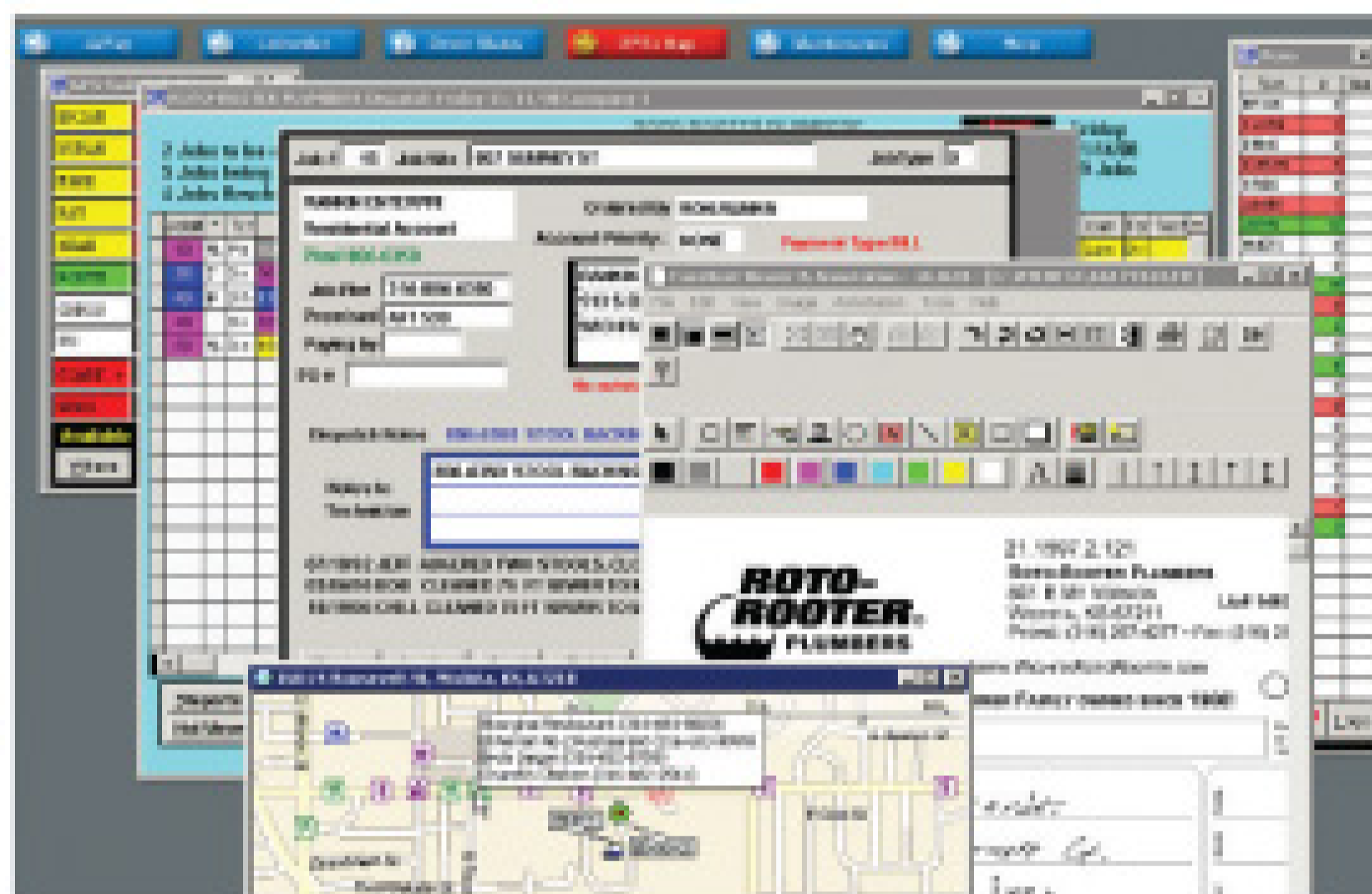

The application allows customers, jobsites, employees and vehicles to have multiple attachments, including notes and scanned images such as permits, invoices, packing lists, photos and digital pen documents.

Bookkeepers can calculate payrolls with multiple commission schedules by job type and with different hourly rates. They can set up sales taxes for different rates for labor and parts with city, county and multiple-state reporting. The system also tracks inventory for each job and generates purchase orders automatically. No matter where it runs, the data is backed up. 800/658-1676; www.famhost.com.



Hauling/Scale Management

With just a few mouse clicks, PC Scale Tower software from PC Scale Inc. makes routing and mapping, dispatch, billing and collections, scale management, and customer service easier. The program integrates with third-party software, such as accounting, structured query language (SQL), and client/server computing. 800/962-9264; www.pcscaletower.com.

Modular Design

The Summit Service Profit Builder from Ritam Technologies is a work order-based job tracking, customer accounting and operations management system. Tasks include detailed order entry with diagrams, technician and sales commissions, invoicing and receivables, automatic credit card processing, complete job history with warranty tracking, automatic scheduled maintenance or repeat business reminders, wireless priority dispatching and appointment-based dispatching with equipment reservations, basic or advanced mapping, GPS links, and technician and shop inventory control.

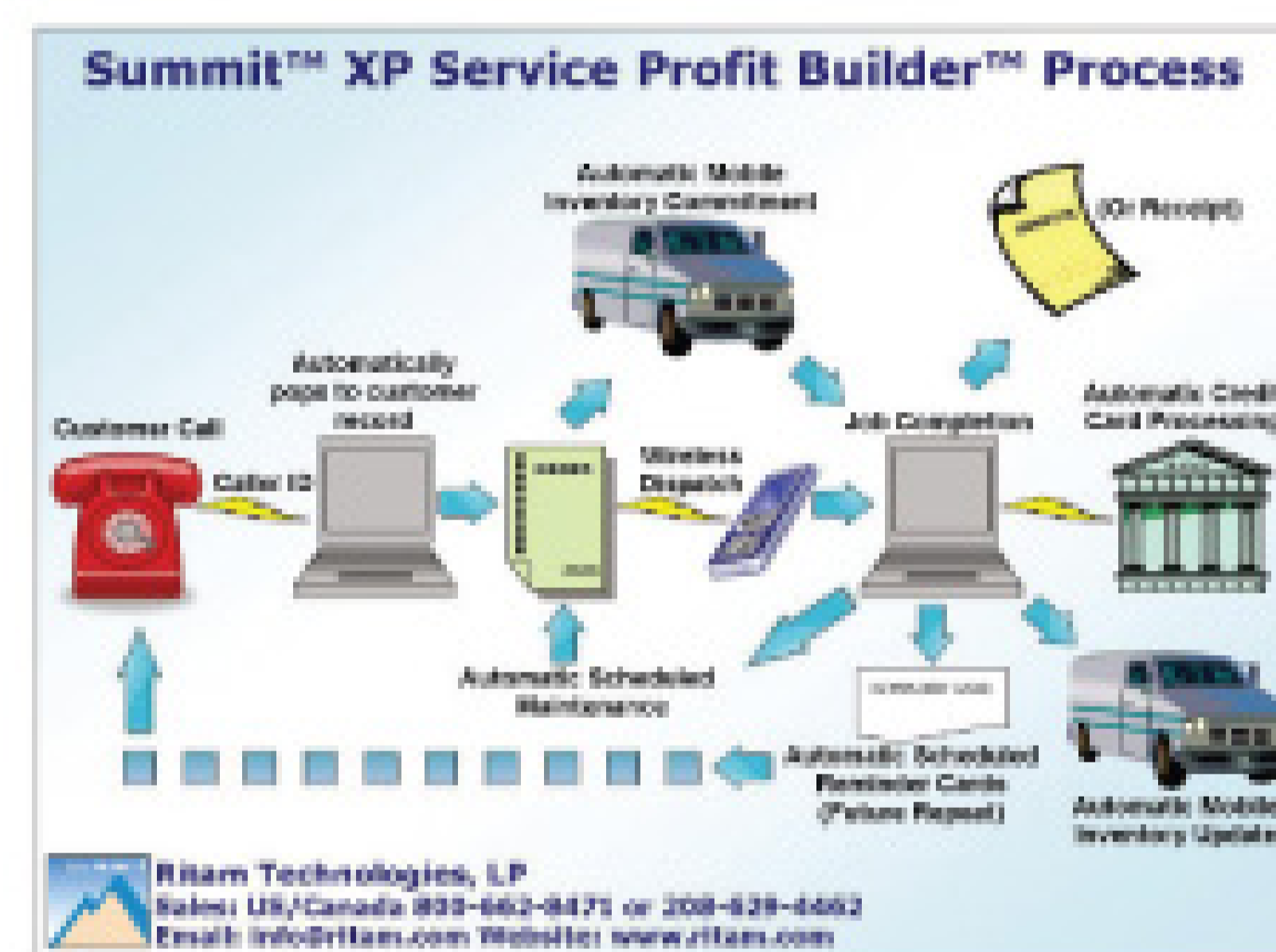

Besides more than 30 ways to view sales data and business sources, the software has numerous scheduling and accounting reports and an advanced version of caller-ID tie-ins. A modular design accommodates budgets and allows features to be added as needed. The application eliminates double entry of customers, technicians, vehicles and inventory, and requires no special security devices. Work orders can be based on time and materials or a flat rate. 800/662-8471; www.ritam.com.

Maintenance Program

The Service Program enables contractors who clean holding tanks and grease traps to easily create work orders and recurring orders, and track gallons dumped, dump locations, time

INTRODUCING MaxLinerCLS

The latest and most comprehensive inside-out, mainline-launched lateral sealing and relining CIPP system around.

MAXLINER[®]
CLS[®]
complete lateral system



MaxLiner[®], the industry leader in providing quick, easy and comprehensive lateral relining solutions using CIPP technology, proudly introduces MaxLinerCLS™, the Complete Lateral System for sealing lateral pipelines starting from inside the mainline and continuing out into the lateral for 10, 20, 30, or more continuous feet. MaxLinerCLS complements the already popular MaxLinerGun™ which is used for rehabilitating laterals and relining vertical pipes. For more information call 877-426-5948 or visit us at www.maxlinerusa.com.

MAXLINER[®]

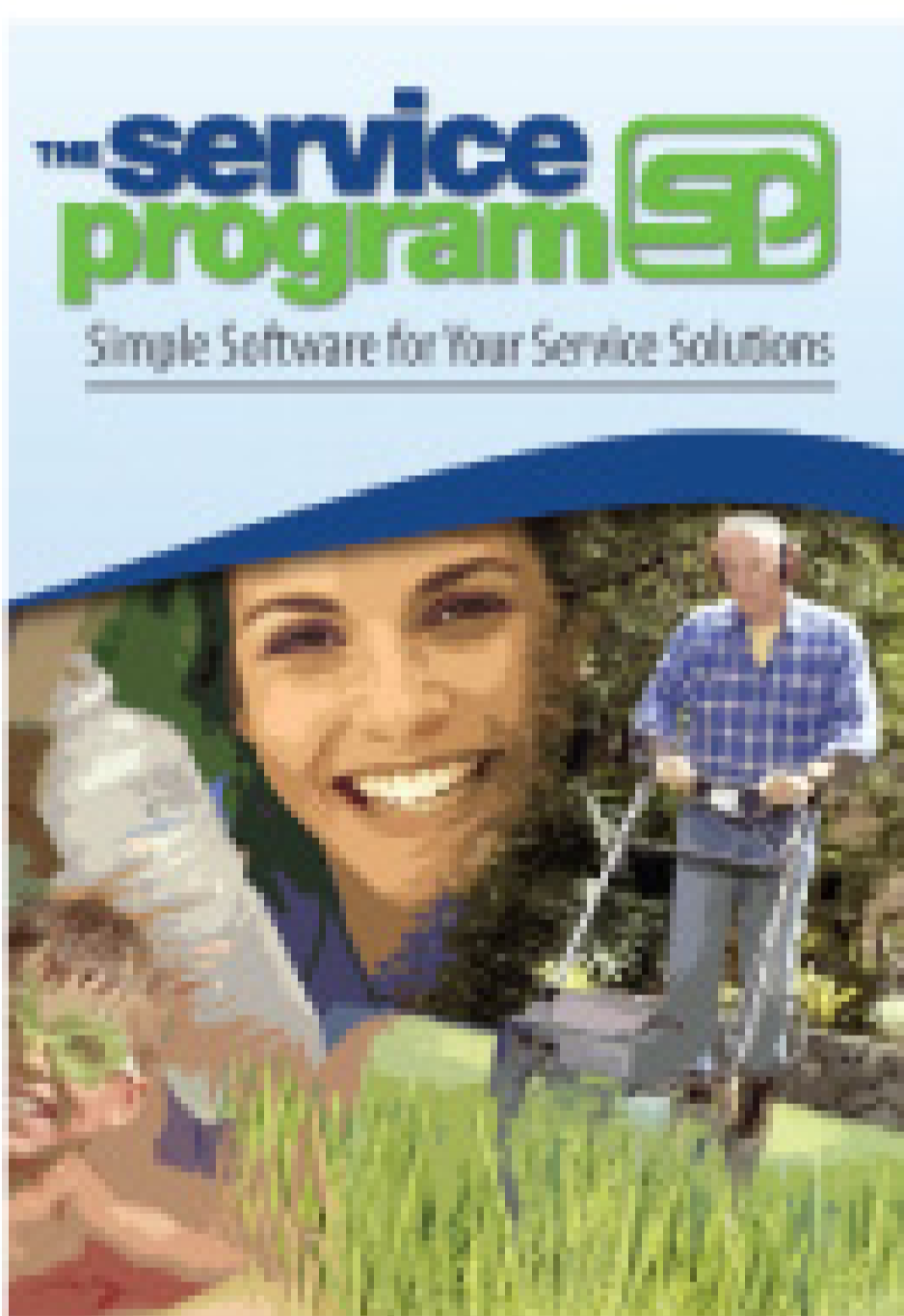

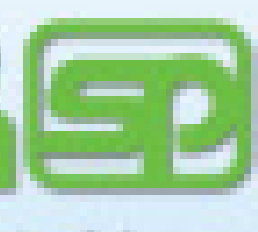
the **service program** 
Simple Software for Your Service Solutions

pumped/dumped, and dump fees by county, permit or tax key. The software also tracks tank and rental equipment locations and sends them into QuickBooks accounting software for printing invoices. It links drawings to customer records. Users can easily create routes and verify that all units are being serviced. The program works with Mappoint and Mapquest for mapping and routing, and includes a Palm/Windows mobile interface. Users can route and map to an LAT/LONG. The Pay as You Go program allows users to pay a small setup fee, then a fixed fee per month. 866/480-1879; www.theserviceprogram.com.

For Septic Pumps

Septic Tracker from Tracker Solutions tracks customer and transaction information. The software generates annual reports for pumping, holding tanks, income and vehicle service. Delinquent customer payments and service-due reminders print with mailing labels, and invoices print at the office or in the truck.

Dispatching has e-mail capability, and work orders have a calendar scheduler. The application provides disposal site usage with automated alarms, tracks employee information, and can import files from other programs. 888/308-0651; www.septictracker.com.

Streamlined Routing

From single vehicles to large fleets, RouteOptix software from RouteOptix Manage-

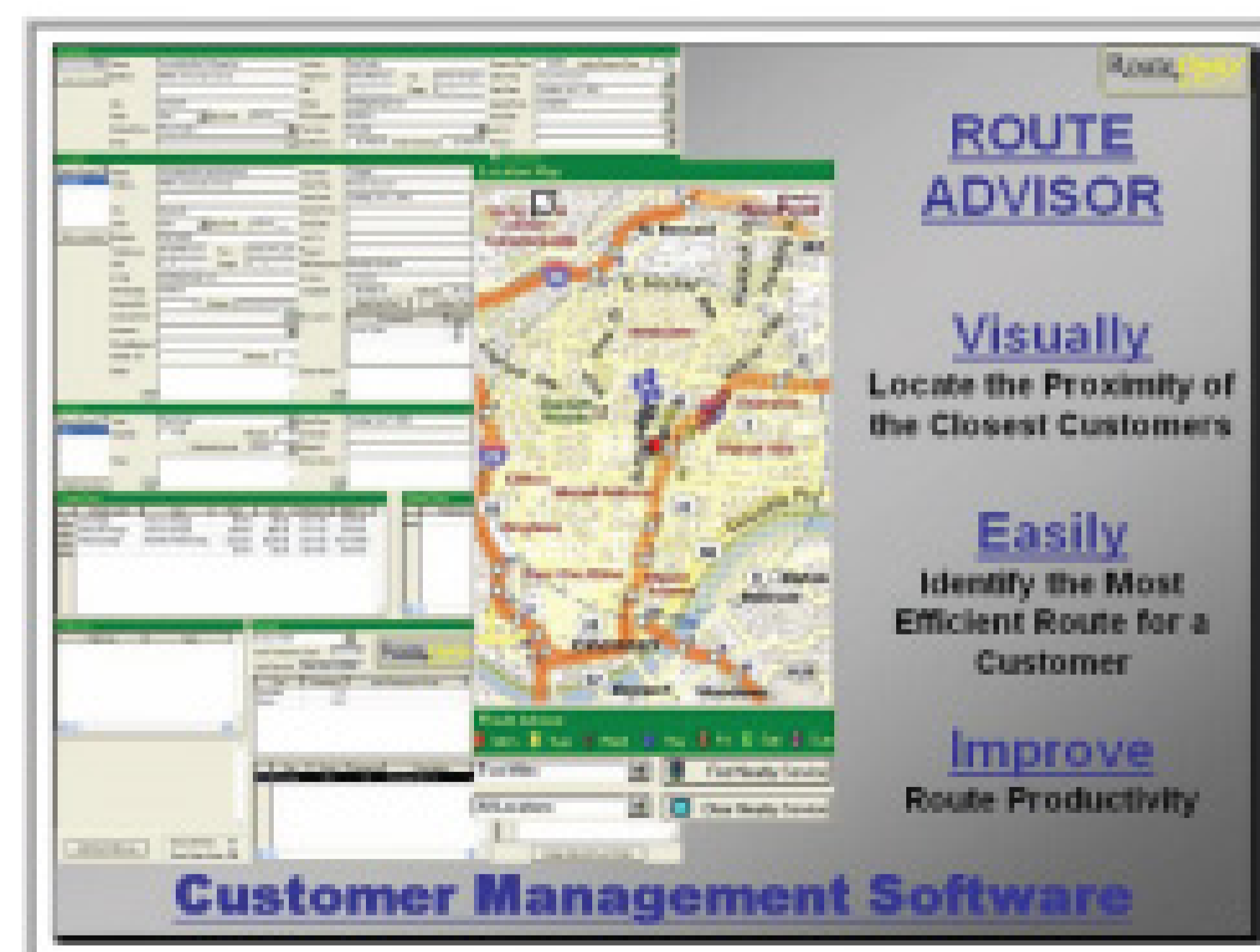

ment Systems Inc. is designed to streamline business. It records detailed customer information, including mailing and billing details, locations with visual map-based confirmation, multiple services, follow-up calls, asset details, charges and routing on a single screen.

A customer service module enables dispatchers to create immediate or future work orders, track routes, and update calls to reflect the service performed. From a single screen, users can generate invoices or review revenue from parameters such as customer, frequency and billed-to-date. MapPoint technology allows users to visually analyze geographic densities by service type, sales representative and service frequency. 866/926-7849; www.routeoptix.com.

Tracking Services

EZTrakR from EZTrakR Systems Inc. validates every service, delivery and pickup with a date and time stamp using tamper-proof iButton technology and PulseStar data collectors. Mapping modules select service days, assign routes, and optimize individual routes.

Probe or GPS tracking appears on high-quality Microsoft MapPoint maps. Point-and-click reconciliation of all deliveries and pickups lets users keep a complete inventory and histories for any unit, location or customer. Most fields for order entry populate automatically. The application integrates with QuickBooks accounting software for invoice production and financial reporting. 866/529-1938; www.eztrakr.com. ■

KMH EQUIPMENT COMPANY

SALES • RENTALS • SERVICE

Indianapolis, Indiana
Marietta, Ohio



VacAll AllJetVac



Presvac DOT 407/412



VacAll AllVac AVR8

AVAILABLE FOR SALE, RENT OR LEASE/PURCHASE

1-888-564-0202

www.kmhequip.com

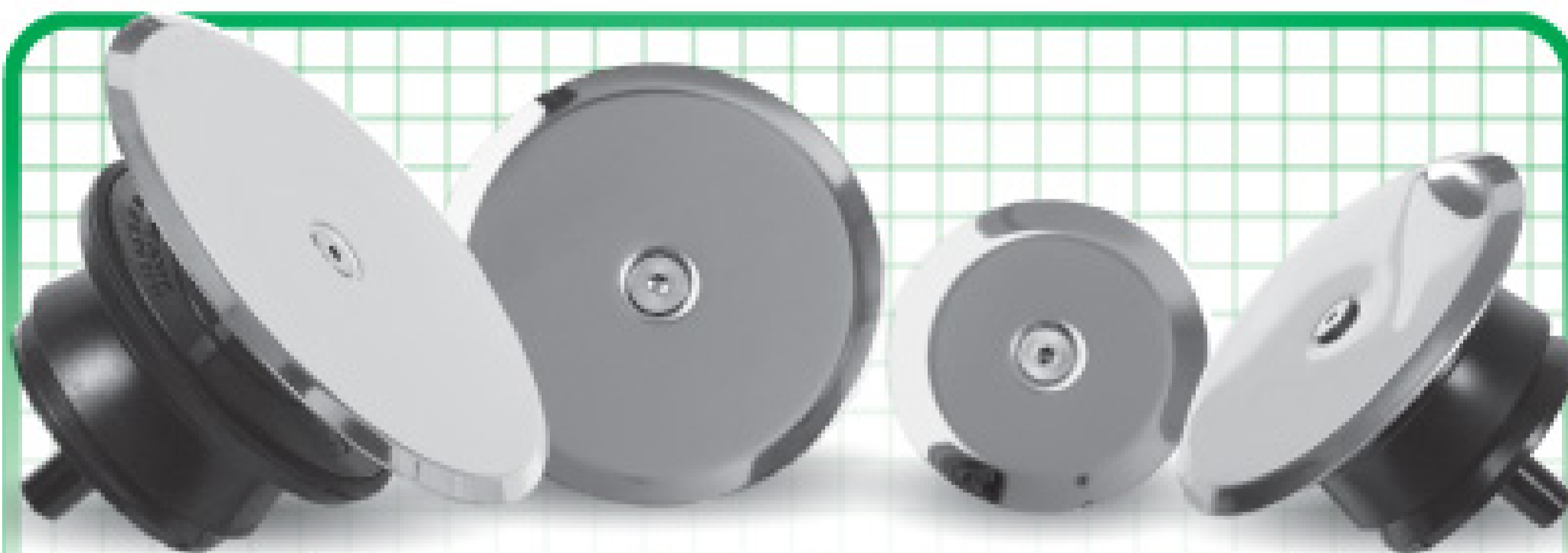

Real-Tite® Plugs with Stainless Steel Cover Finishing Plates



REAL-TITE® PLUGS
INCORPORATED



Stainless Steel Plugs for
Driveways & Warehouses

Custom Printed Plugs
Advertise Your Business Here

800-877-0610 real-titeplugs.com 952-938-0600

AquaNoz
"Engineered Solutions"



Call 1.800.322.0510

Fax: 1.330.722.2698

E-Mail: jmsales@apclsq.com

www.arthurproducts.com

ARTHUR PRODUCTS CO.
an LSQ Mfg Company

EVERYONE NEEDS A GOOD WORKHORSE!

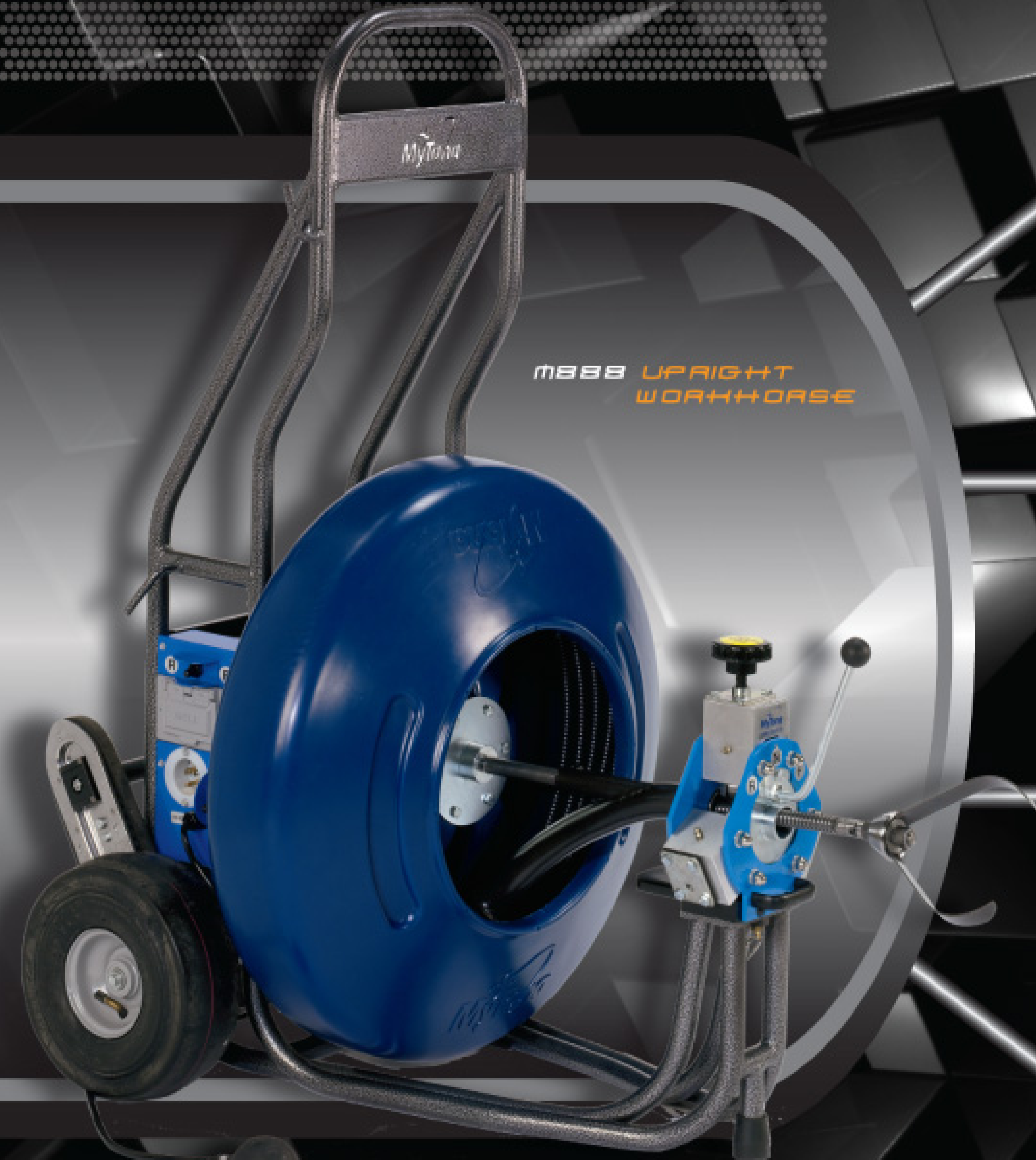

MBB UPRIGHT
WORKHORSE

FEATURES

STAIR CLIMBERS AND WHEEL LOCK

Provides added mobility
Stair Climbers swing down
to lock wheels while in operation



CAST ALUMINUM GEARBOX HOUSING

Hardened Steel shafts & gears
11 pounds lighter than the
old all steel version



REMOVABLE LOADING WHEEL

Provides added mobility
Ease of loading and unloading



SLIDING AUTOFEED

Lets feed arm drop away
for quick change of reel
Locking pin to ensure
solid connection



A MACHINE BUILT WITH
YOU IN MIND

call, click or visit our booth for more info



**High pressure technology that sets the standard
Up to 1000 HP and 50,000 PSI**



HAMMELMANN®

Packing free pumps



HDP 753
70 gpm @ 20K

"Dynamic Seal" which replaces high-pressure packing. This metal-to-metal seal is particularly suitable for high and ultra high pressures. Special characteristics of this design include high volumetric efficiency and a minimal number of components.

Hammelmann Corp.
600 Progress Road
Dayton, Ohio 45449
1-800-783-4935
mail@hammelmann.com

Accessories



3 D Tools
150 gpm
20 K

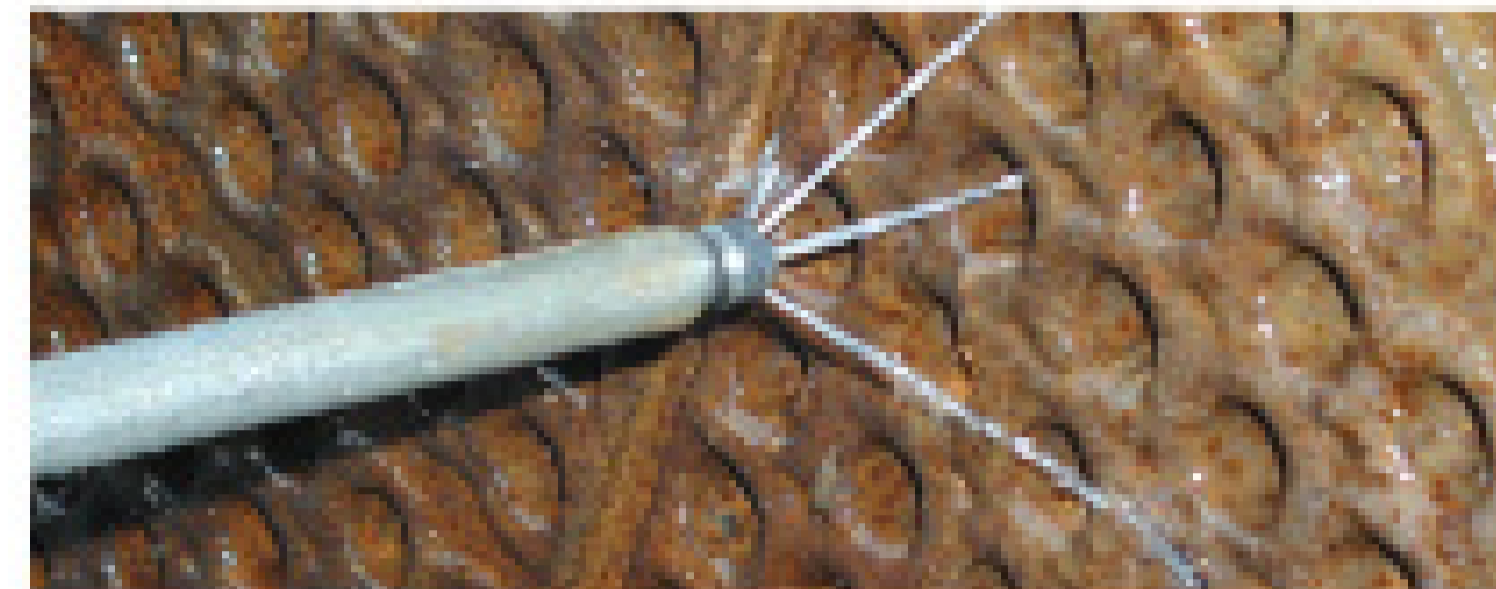

www.hammelmann.com

Complete rental & service package!

We offer pumps up to 50,000 psi and 1000 HP in our rental fleet along with tank cleaning equipment and water-blasting accessories. A complete parts and service center located in Laporte, Texas for all Hammelmann products.



Hammelmann Houston
625 North Broadway
La Porte, Texas 77571
1-866-317-8677
bobriant@hammelmanncorp.com

SEWER Equipment & Supplies

Booth 9107

March Special

200ASR Series Jetter

Starting at only **\$11,999**
(Financing Available)

INCLUDES:

- 31 - 45 HP Engine
- 10 - 15 GPM water flow
- 2500 - 4500 PSI
- 200 gallon tank
- Large capacity reel
- 180 degree Swivel reel
- Super Duty trailer
- 300' of 1/2" jetting hose
- 200' of 3/8" jetting hose
- 10 foot leader hose
- 5 Nozzles
- 25 gallon gas tank
- Rear work lights
- Safety strobe lights
- Wireless remote operation system
- Self-contained antifreeze system
- 2" tiger tail

We offer over 30 different models and have units starting at \$7,300

For all your jetting needs please call **202-330-8395**
www.sewerequipmentandsupplies.com

BIG SAVE ON

Portable Video Inspection Camera System

From Only **\$389**

CALL TODAY
408-573-8899

Booth 6005

Dealers & S'Reps Wanted!

SWJ-2188

SWJ-3188D

SWJ-3188DN

Email: forbest2007@yahoo.com <http://www.FORBESTcorp.com> **FORBEST**

More Plumbing and Drain Cleaning Professionals Choose Nu Flow

We Have What Your Customers Want

With Nu Flow® you will:

- Be part of the largest network of lining licensees worldwide
- Receive the fastest, most reliable 24/7 tech support of any other small diameter lining company in North America
- Have the support of corporate to quickly develop custom products to meet your customer's specific needs
- Receive the most effective and extensive training program in the pipe lining industry today
- Have access to patented and proprietary lining systems which have withstood a longer test of time than competitors' products
- Buy products and specialty equipment, ensuring the highest quality workmanship and materials, directly from the manufacturer
- Have access to potable and drain technologies as well as water filtration products - No one else offers as complete a solution
- Be able to offer your clients the most affordable "no dig/no destruction" lining solutions as alternatives to repiping
- Meet your customers' demand for this technology so they don't have to get it from your competition...

Drain/Sewer Lines

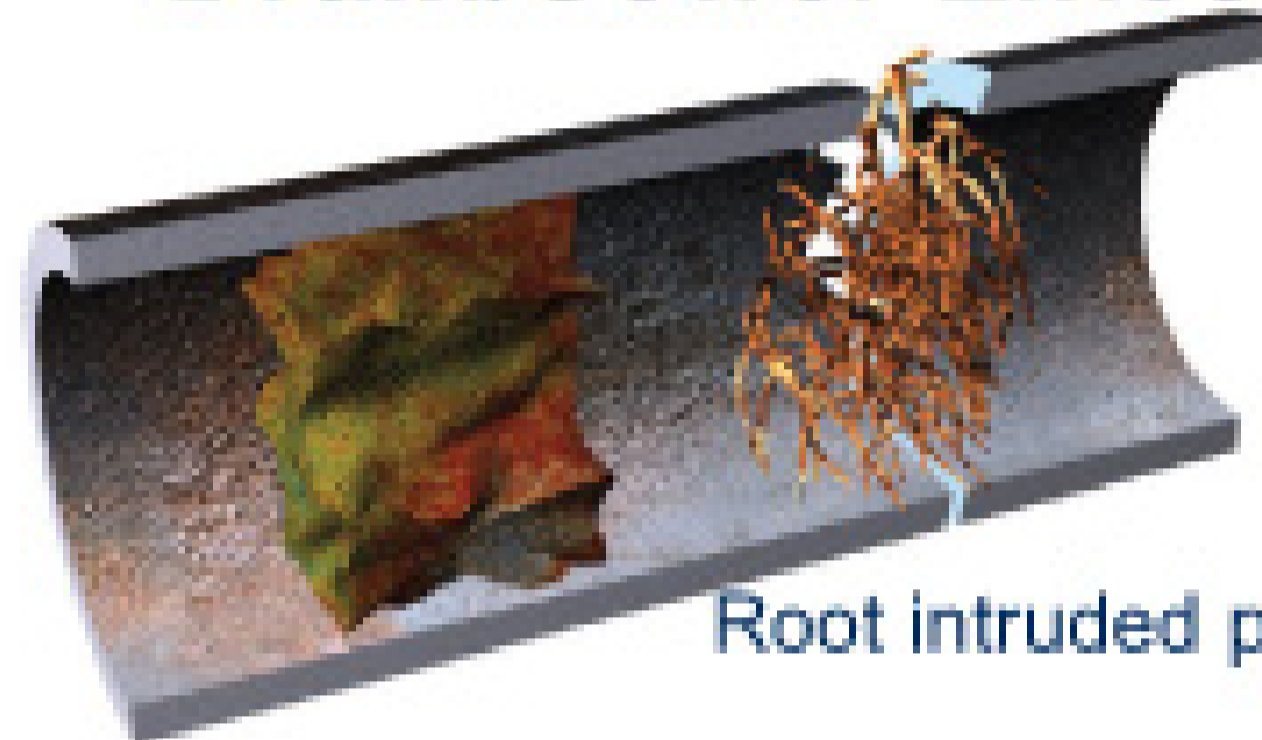

Root intruded pipe



After pipe has been cleaned the liner is pulled-in-place and inflated

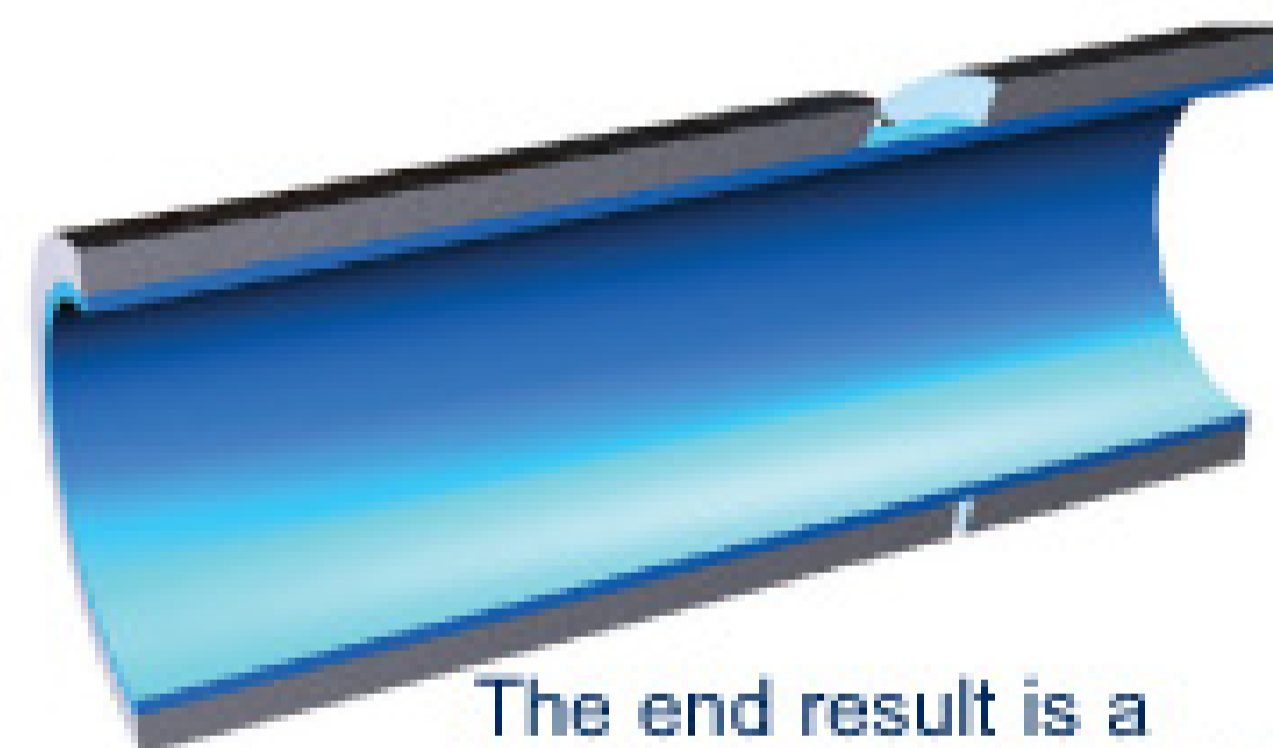

The end result is a permanent structural liner

What can Nu Flow® do for you?

Profits

Lining offers your clients options, convenience and cost savings - an advantage to you in a highly competitive marketplace.

Knowledge

On-site and classroom training teach you to line drains with a two-man crew. Line potable water pipes with a three-man crew.

Versatility

Nu Flow® is the only company that offers patented solutions in both technologies, allowing you to line any pipe, anywhere!

Support

Multiple corporate locations provide 24/7 technical support.

Potable Water Lines

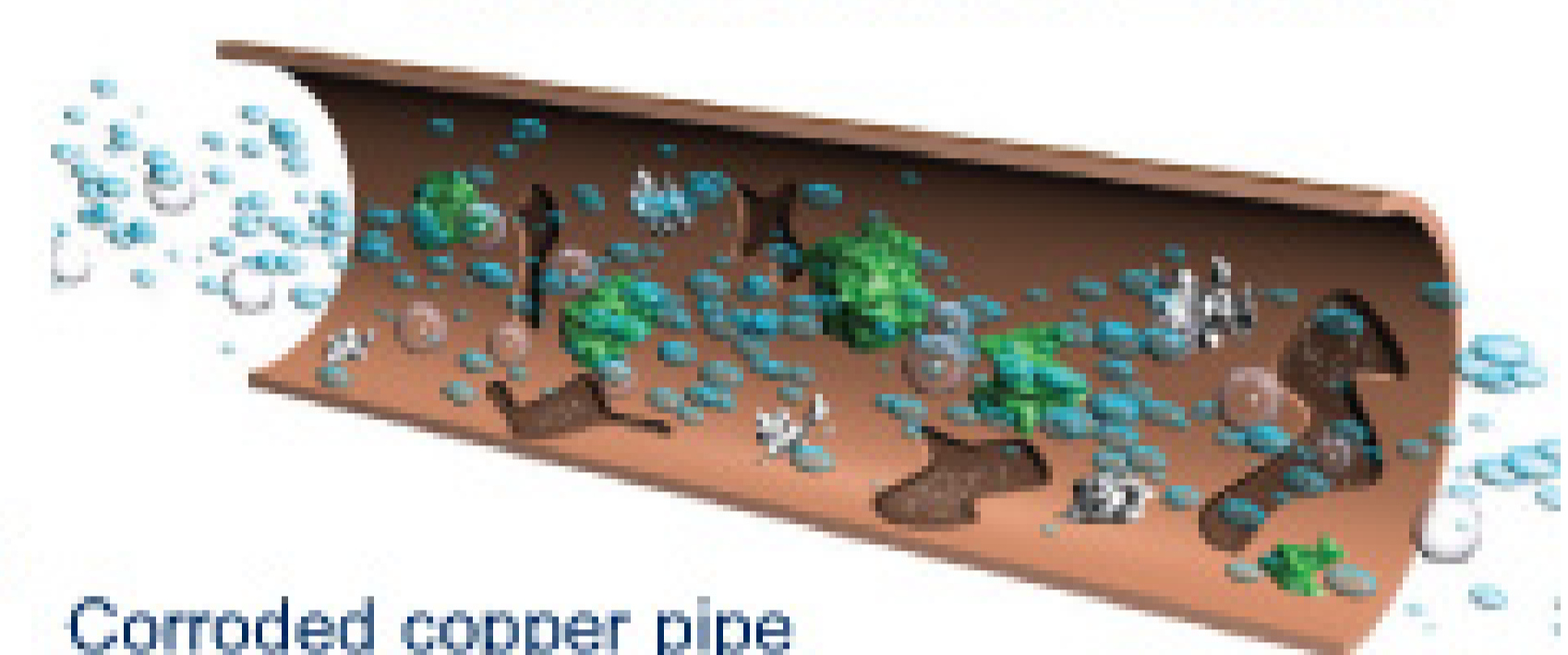

Corroded copper pipe

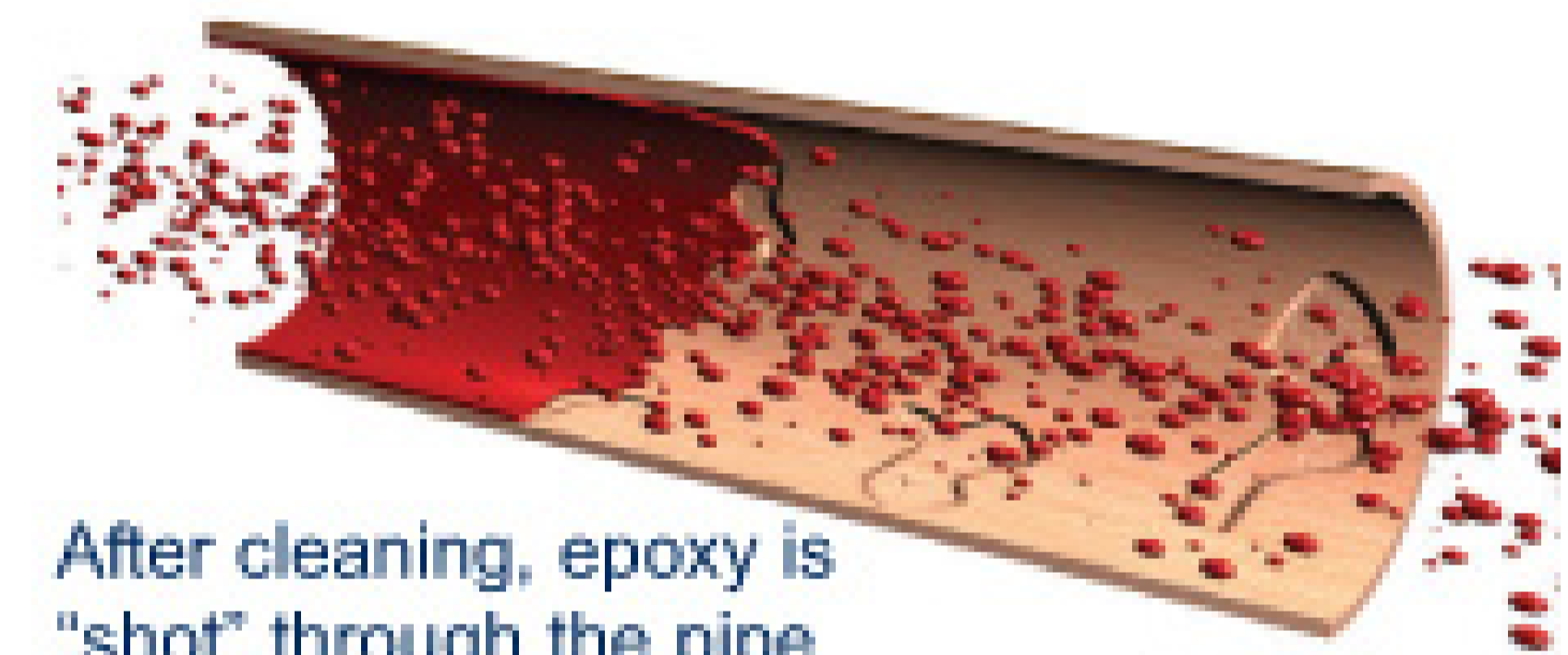

After cleaning, epoxy is "shot" through the pipe



The end result is a permanent barrier between pipe and water

See you at the Pumper/Cleaner Expo!

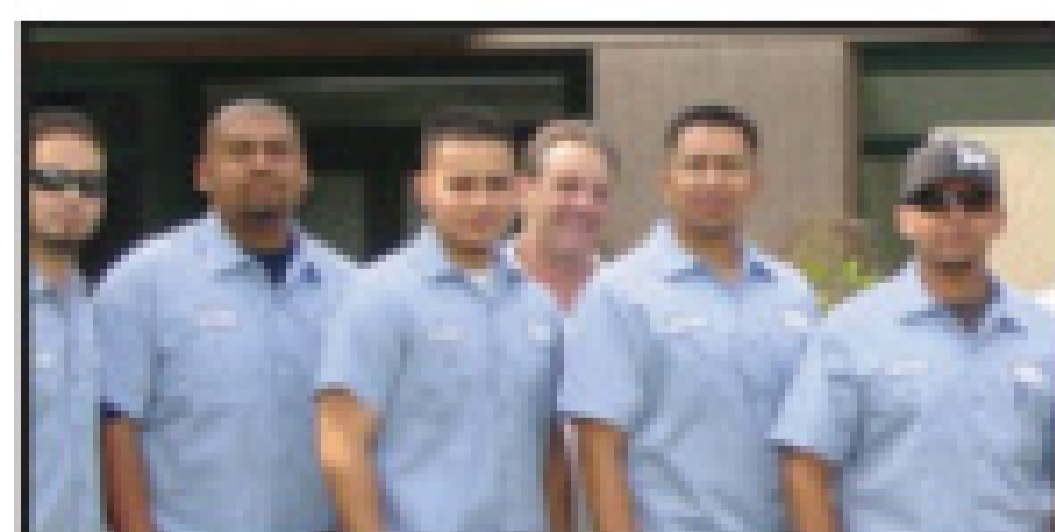

Join our growing network of over 250 licensees - before your competition does!

*U.S. Patents #6,691,741 and #7,216,674 - Additional Patents Pending

at the **Kentucky Exposition Center**

937 Phillips Lane, Louisville, KY 40209-1398

www.kyfairexpo.org

Booth #5081



*Master Licensee, U.S. Navy Patent #5,707,702

www.nuflowtech.com ♦ 1-800-834-9597 ♦ sales@nuflowtech.com

Upright! Done Right!

Built In Toolbox

For easy access to the tools you need.

Quick Change Reel

Save time by easily switching reels and cable to the right size. No belt needed.

Heavy-Duty Motor

1/2 Horsepower direct drive gives you more torque than similar machines.

Right Size

At under 23" wide, it easily fits through a 30" doorway.

The DM175 Gladiator From Duracable – An Upright Drain Cleaning Machine You Can Count On

We built it right. With features that make it easier to use, move, maintain, and switch reels, the Upright machine saves you time and money. The DM175 uses a direct drive system with a 10:1 gear ratio for more torque. With built-in stair climbers and a quick change reel, the DM175 is the upright machine you've been waiting for.

Call today! 877-244-0556

www.duracable.com • sales@duracable.com

Duracable
Manufacturing Company

10% OFF* Call Today & Receive 10% off Any Upright DM175 Machine Package

* Must mention promo#224. Call for details. Expires March 31, 2009

FRUITLAND offers quality

SEALED WORM GEAR DRIVEN BEARINGS

Complete with **HYDRAULIC MOTORS!**



Sealed Boom Swivel Bearing driven by WORM GEAR and hydraulic Motor.

In addition to many sizes and types of Boom Swivel Bearings from 4" to 17" with and without Gears, we will custom design to your specifications!

**We have Replacement
Hose Reel Bearings
for most makes**



FRUITLAND TOOL & MANUFACTURING

324 Leaside Ave., Stoney Creek, Ontario L8E 2N7 Canada - Tel: (905) 662-6552 - Fax: (905) 662-5412
Toll-Free from the U.S.A. and Canada: 800-663-9003

Speedway™
DRAIN CLEANING PRODUCTS

The ***Fastest Growing Name***
In Drain Cleaning Machines

COME SEE US AT THE PUMPER & CLEANER SHOW IN LOUISVILLE, KY. BOOTH # 8161



ST-8500

NEW!

**All the same great features
as the 6500 series PLUS!**

New free spinning inner drum

New reinforced inner core cable

Perfect for roots

COME SEE US AT THE PUMPER & CLEANER SHOW IN LOUISVILLE, KY. BOOTH # 8161

**Speedway™ Offers a Complete Product Line of Contractor
Tough, Plumber Approved Designs. You Can Count on
Speedway™ to Deliver Unmatched Performance & Value.**

**For More Information and a Catalog,
Call 800-835-2200 or Visit Our Web Site**

www.speedway-tools.com



RAUSCH ELECTRONICS USA, LLC

Visit us at the
Pumper & Cleaner Show
February 25-28, 2009

BOOTH #2031

- TV Mainline & Lateral Pipe Inspection
- Pressure Testing of Joints & Sections
- Point Repair System - QuickLock
- Lateral Flushing
 - Laser Pipe Profiling
 - Software

Visit us online at www.rauschtv-usa.com

370 New York Avenue, Chambersburg, PA 17201
(877) 728-7241 • reusa@rauschtv.com



rausch



FIRST... BEST... ALWAYS!



FIRST...

with a full flow low profile riser and open drum slot allowing for smooth even hose wraps that don't pinch, kink or stress the hose.

BEST...

and largest selection of high quality, professional grade hose, cord and cable reels for the air, water, oil and electric industry.

ALWAYS...

100% pure Coxreels quality in every reel we design & build.

Safety Makes Sense

USA MADE - USA QUALITY - USA SUPPORT

800-COX-REEL

Toll Free: 800-269-7335 • Fax: 800-229-7335
Email: info@coxreels.com

www.coxreels.com

Int. Tel: 480-620-6396 • Fax: 480-620-5132

COXREELS®

Your Reel Source

2009 American WJTA Conference and Expo

August 18-20, 2009

Marriott Houston Westchase • Houston, Texas

- **Live, Onsite Demonstrations** of a variety of sewer and pipe cleaning and other industrial cleaning applications, paint/coating removal, concrete preparation, testing the durability of safety equipment, industrial vacuum/air moving operations, and cutting.
- **Waterjet Expo:** a variety of companies will display waterjetting equipment, systems and supplies, and industrial vacuum/air moving vehicles.
- **Waterjet Boot Camp**—Industry experts offer information and suggestions on ways to help contractors buy smart, improve efficiency and generate profitable new business.
- **Pre-Conference Workshops**—① **Safe Operation of Industrial Vacuum Equipment.** Learn how to get the most out of your industrial vacuum truck/air mover by enhancing production and maximizing safety. ② **Waterjet Technology: Basics and Beyond.** Start with the basics and follow up with an in depth look at waterjet applications: Hydro-Excavation, Surface Preparation, Cleaning Applications, and Cutting Applications.
- **Emerging Technology, New Applications**—Hear some of the world's foremost engineers and researchers share new developments in applications, mechanics, equipment, and procedures.

\$30 Expo Pass

One-day pass includes exhibit hall, live demos, and waterjet boot camp on 8/19 or 8/20.

Call 314-241-1445 to register.

WJTA
WaterJet Technology Association

Visit WJTA's web site, www.wjta.org, for regularly updated Conference information or contact: WJTA, 906 Olive Street, Suite 1200, St. Louis, MO 63101-1448, phone: 314-241-1445, fax: 314-241-1449, email: wjta@wjta.org



CLEANING SEWERS CAN BE TRICKY. USING YOUR EQUIPMENT SHOULDN'T BE.

Discover how our Camel makes the job easier.

- Industry's simplest operation sequence - single control panel set-up that even the newest employees can quickly learn
- Faster, cleaner unloading and washdowns with exclusive Ejector Plate debris removal system
- Dryer loads, fewer trips to the dump and reduced disposal costs with innovative "Super Pak" dewatering option
- Simplified diagnostics with CAN Bus wiring

Contact Super Products for a FREE DVD that shows why our Camel is simply the best combination unit on the market today!
800.837.9711 • www.superproductscorp.com



Easy to Operate; Easy to Clean; and Easy to Maintain.

Tech Perspective looks at technology-related issues and provides information and advice that cleaning professionals can apply to equipment selection and to their daily work in the field. Industry members are welcome to offer ideas for this column. Please direct them to editor Ted J. Rulseh, editor@cleaner.com.

Tech Perspective

An Ounce of Prevention

Like any machine, your computer needs regular maintenance. Here is some basic advice for keeping your system running fast and protecting it from threats.

By Doug Day

You tell your customers to do maintenance on their drain and sewer systems. Do you take your own advice when it comes to your computer?

Like any machine, your computer needs care. If you neglect it, it will slow down significantly and cause you all manner of other problems. Here is some basic advice on keeping your computer equipment – without which your business can't function – in the best possible operating condition.

Basic housekeeping

You may not know it, but your computer is full of junk files. Every time you open a file, your computer stores a record of it. The same is true of every Web site you visit, every change you make to a document, every e-mail you send or receive, every program you install. It doesn't take long for all of these little bits and bytes to add up, and slow your computer down.

Want to see how much junk you have lying around? If you use Windows, click on Start, All Programs, Accessories, System Tools, Disk Cleanup. There, you'll see the junk, from old and useless setup files, to temporary files from the Internet and programs you use, to your recycle bin.

There are many free or cheap programs that will help you keep your computer clean and efficient: registry cleaners, spyware and virus programs, start-up managers, and others. But be careful! Stick with well-known programs or companies,

or you may just make the problem worse. It helps to do a quick Internet search to see what other people are saying about such programs before installing them yourself.

Or better yet, hire someone to do all of this for you. Any computer repair shop or IT firm will know what to do (as will many 13-year-olds).

Why it slows down

You might think of your hard drive as a filing cabinet. In a way, it is a file cabinet, but one that belongs to a very disorganized person. Every time a file is changed, its data gets saved in different places; it is not all kept together. It's like putting pieces of paper in a filing cabinet in the order you receive them instead of in separate folders.

The computer is smart enough to go around and piece it all together. Over time, though, you get all sorts of wasted data sitting around on your hard drive. So it takes the computer longer to find everything. The fix is called a defragmenting (defrag) of your hard drive. It takes all those little file segments and puts them together.

In Windows, you access a simple defrag tool at Start, Programs, Accessories, System Tools, Disk Defragmenter. There are other programs available for a small fee, or even free, over the Internet.

Shut it down

As a general rule, you should get into the habit of turning your computer off now and then if you don't turn it off every night. Turning

your machine off lets all the programs reboot, cleaning out some of the junk that may be slowing your machine down or causing it to crash. It also clears out the computer's memory and will shut down any unneeded or defective applications that are running in the background.

To see all the processes that are running, open Task Manager (in Windows) by holding down the Control, Alt, and Delete keys at the same time (or Control, Shift, Escape). Now click on the Processes tab and you'll probably find dozens of little programs that are running. Many programs even keep running in the background after you shut them down.

Stay updated

Are your computer programs and operating system up to date? Most offer a free update service when you install them. Use it. Updating fixes little bugs in the program and fixes any security vulnerabilities the crooks have found. Sometimes, the company sends out an update that simply improves the program's performance or features.

Use the firewall

Your operating system probably includes a firewall. Use it. Simple explanation: A firewall helps keep bad guys and bad stuff out of your computer. It does not protect from viruses or spyware, though virus programs sometimes include a firewall. In Windows, you turn the firewall on by clicking on Start, Control Panel, then double-clicking on Windows Firewall.

Keep the registry clean

First, a disclaimer: If you don't know what a registry is, you don't want to mess with it. If you know what it is, you still don't want to mess with it. If you really know what you're doing, mess with it at your own risk. You can do permanent damage.

A computer's registry keeps track of everything on your computer – all the settings, programs, user preferences and configuration information, and a whole lot more. If you're curious, you can see the registry (in Windows) by clicking on Start and Run, type in regedit and click on Okay. You'll see about five funny-looking folder names like HKEY_CLASSES_ROOT. Just click on one of the plus signs to expand that folder and you'll see hundreds or thousands of settings – and that's just the beginning. Now, close the editor and don't ever go back there again.

The registry can be corrupted by viruses, and installing and uninstalling software will leave unneeded settings that will eventually reduce the performance of your computer. Registry cleaners know what to clean out and what to leave alone.

Danger lurks

If you are connected to the Internet, you are vulnerable to attacks from hackers, crooks and just plain old ruffians who happen to know a lot about computers. If you don't protect yourself, you will eventually have a problem with malware – the generic term for malicious software. It could be a nuisance, or it could

destroy your computer. While most malware is designed to attack machines running Windows, some target Macintosh machines. Spyware is a risk to both.

A computer virus destroys data or programs, can copy itself, and spreads through the Internet and portable storage devices like flash drives. You need an anti-virus program. But do some research – some anti-virus programs slow down your computer so much that they are worse than many viruses! There are any number of free programs available

Spam is normally advertising a scam, such as the lady in Zimbabwe who wants you to help her get money out of the country and will give you \$3 million for your trouble. (Yes, people do fall for that – on a regular basis.)

Spam also advertises rip-off schemes, such as donations for otherwise worthy causes, products that don't work or that will never be delivered, counterfeit medicines, and college degrees without taking classes.

Phishing is similar to spam, except it is an outright, boldfaced

crime. It tries to trick you into entering passwords and personal data like bank account numbers by pretending to be from a legitimate business. It can be hard to detect, but it's easy to avoid. Your bank or other business won't ask you for such personal information in an e-mail.

Don't be surprised the first time you run this program – it will find literally thousands of fixes, and then fix them in just a minute or two.

CCleaner from Piriform. This free program quickly cleans out junk files and cookies (little packs of data sent from Web sites to your browser), cleans your registry, and speeds up your computer. It's quick and effective, but not as broad as Advanced SystemCare. Neither catches everything, and both catch some things the other misses.

system the more work it will take.

Is it worth it? Well, imagine losing all the data about your company: billing records, tax records, customer information, work schedule, payroll – everything! Backing up comes at a cost, but it is much less expensive than the cost to recover data from a failed hard drive.

If you're working on a single computer or a few that are not networked together, you'll need some kind of a storage device, such as an external hard drive, and software to conduct the backup function for you.

There are many free or cheap programs that will help you keep your computer clean and efficient: registry cleaners, spyware and virus programs, start-up managers, and others. But be careful! Stick with well-known programs or companies, or you may just make the problem worse.

and, for the most part, they work as well as the ones you buy. Either way, make sure the program includes an update feature. New viruses hit the Internet every day.

If you've spent more than 18 seconds on the Internet, you have some kind of spyware on your computer. Sure, that's an exaggeration, but you get the point (it probably doesn't take 18 seconds to get infected). Spyware can get into your computer in any number of ways, usually through some kind of a download (though you may not even know you're downloading it).

Spyware is much like a virus. It can collect information about you and your computer and send it to someone you probably wouldn't like very much. It can also install other software and spyware, change your settings, and make your computer do things you don't want it to do. It is also a common reason for your computer operating slowly. If you suddenly start getting a lot of advertising pop-ups, your Internet home page changes, or your computer slows down or just starts acting funny, you are infected.

Spam and phishing

Spam e-mail is more of a nuisance than a threat, though spam messages can also carry viruses that turn your computer into a secret spamming computer. Experts say spam makes up from 80 to 95 percent of all e-mail traffic.

Do not reply to spam or click on an unsubscribe link – or any other link – in a spam message. Replying only tells the spammers they have found a working e-mail address. So they'll add it to all their lists and then sell it to other spammers. What do you do? Just use your delete key.

Do not reply to spam or click on an unsubscribe link – or any other link – in a spam message. Replying only tells the spammers they have found a working e-mail address. So they'll add it to all their lists and then sell it to other spammers. What do you do? Just use your delete key.

Protection

Invest a little bit of time to build up your computer's defense system. Without making any endorsements, here are a few popular programs – there are many others. Check each program's user agreement to see if you qualify for the free version. If you don't, the subscription is usually only a couple of dollars. Normally, it takes just a couple of minutes to download and install these services.

Advanced SystemCare from IObit. With one click, the free version quickly finds and erases spyware, malware and many viruses (and prevents them), safely cleans up your registry, and cleans out junk files. It also optimizes your Windows settings, looks for settings that have been hijacked by malicious software, defrags your disks, and even cleans

Ad-Aware from Lavasoft. The free version is very effective at searching out and destroying spyware, malware, viruses and adware. (Like the others, adware downloads ads to your computer based on such things as which Web sites you visit).

Spybot Search and Destroy. A free program that asks for voluntary contributions to help with the cost of keeping the program current. It is one of the most popular spyware programs that removes threats and also prevents known spyware programs. It even protects critical portions of your registry.

SPAMfighter Standard. A free service from SPAMfighter for Outlook, Outlook Express and Windows Mail, it can also be upgraded with a paid subscription.

avast! Home Edition. This is another free anti-virus program that can be upgraded with a subscription. While not perhaps as fancy as paid services, it seems to do a good job without bogging down your computer.

There are many commercial programs that protect you from malicious software. Among the popular companies are BitDefender, Kaspersky, Webroot AVG, Trend Micro, McAfee and Norton.

Back it up

Last and probably most important is to make regular backups of your computer. Depending on your setup, this could entail a fair amount of work. Oddly, the smaller your computer

You can also do it to CDs or DVDs or flash drives, though that can be limited by the amount of data you are backing up.

If you're on a network, you can add software to do it for you. You can also use one of the many online services that will store your backup as encrypted files. One of those, Carbonite, says that 43 percent of computer users lose important files every year.

A local backup can prevent problems from sudden computer or disk failures, viruses, worms and the other killers. Better yet is a remote backup, where files are stored somewhere away from your place of business. That will protect you from small problems and major disasters such as fire, flood or tornado.

Business simply doesn't function without computers these days. So take the time to protect one of your most valuable assets. For those who decide to heed this advice: Good job! For those who choose to ignore it, you might as well hear it now: Told you so. ■

Doug Day is a writer and frequent contributor to COLE Publishing magazines. He's not an information technology professional, but his two adult sons are. They reviewed this article and were surprised by how much dad had learned from them.



J.M. MCKINNEY CO.

*Call us for
All Your Ridgid
Tool Needs!*

Factory authorized service center for Ridgid/Kollmann and SeeSnake.

RIDGID / KOLLMANN SEESNAKE DIAGNOSTIC TOOLS

Free Shipping on All Cameras!

Call Toll Free: 800.821.7275

Fax: 888-330-6989

www.jmmckinney.com
Leasing Plans Available



MAIN OFFICE Hawthorne, CA 310-978-9650	SAN DIEGO OFFICE San Diego, CA 619-461-4211	ANAHEIM OFFICE Anaheim, CA 714-632-1315	VALLEY OFFICE Panorama City, CA 818-786-2527
---	--	--	---



If this was your home and you needed your sewer lateral replaced...
Would you dig?

Maximize your profit with Maxliner® Lateral Lining System

- Personal Onsite Training
- Financing Available
- Experienced Personnel For Service Solutions
- 24/7 Customer Support



PRIMELINE PRODUCTS, INC.

"Your Prime Source for Solutions, Products & Training"

MAXLINER®
Manhole/Wetwell Rehabilitation Products

MaxLiner® Lateral Lining

Maxliner® uses an engineered composite made of a felt tube and an epoxy ambient cure resin to invert a liner into the lateral from the property line or cleanout to the connection with the sewer line, forming a "pipe within a pipe" to effectively repair broken pipe, leaking joints and other infiltrating defects in the lateral pipe.

de neef

CONSTRUCTION CHEMICALS, INC.



- > Fast Setting Plug Materials
- > Spray Mortars
- > Epoxy Coatings
- > Concrete Restoration Products
- > Waterstop Materials
- > Urethane Grouts
- > Acrylate Grouts
- > Grout Pumps
- > Expansion Joint Materials



CHERNE UNDERGROUND PRODUCTS

Plugs, Smoke Testing, Joint Testing Equipment!!

We are Committed to Earn Your Business!! Call Us Today!!

Toll Free: (877) 409-7888 • International: (407) 772-8131 • Visit Our Website: www.primelineproducts.com

Lateral Lining ~ Manhole Rehabilitation ~ Chemical Grouts ~ Internal Seals ~ Concrete Restoration Products ~ Epoxy Materials ~ Testing Equipment

ALL THE TOOLS OF THE TRADE. FROM ONE SOURCE.



AQUATECH

COMBINATION MACHINES ENGINEERED & BUILT AROUND THE OPERATOR.



O'BRIEN®

JETTERS THAT PAY FOR THEMSELVES. AGAIN, AND AGAIN, AND AGAIN.



ultraVac®

THE NEW POWER IN HIGH VACUUM LOADERS.



X-vac®

VACUUM EXCAVATORS. THINK OF THEM AS SURGICAL INSTRUMENTS.



When you invest in any of the Hi-Vac Corporation Brands, you are getting "The most value for your money". They are designed to be the easiest to operate. Cost less to maintain. And, are built tough to withstand the test of time.

Hi-Vac®

HI-VAC® CORPORATION

740-374-2306
USA 800-752-2400
FAX: 740-374-5447
hi-vac.com

2009 Pumper/Cleaner Exposition

Booth #40



Air Machines
Liquid Vacs
Liquid Rings
Roll-Offs
130 Bbls
Cyclones
Combos

**YOU MIGHT AS WELL
RENT THE BEST.**

NEED IT? RENT IT!

1-888-955-2087

Mississippi • Louisiana • Texas • South Carolina

www.vactruckrental.com

**VACUUM
TRUCK
RENTALS
INC.**

AMerik FIBER Spot Repair

Engineering, Inc. Point Repair for Sewer and Storm drains

Benefits:

- Keep rehab work you find in your company
- Calculations and support for municipal acceptance
- Complies with ASTM 2019 liner specifications
- Competitive price, low first cost, no license fee
- Field training and support • Territories available

Before



After



Proprietary Features:

- Proven product with 10 year history
- Liners 6 to 45 inch diameter and 2 to 150 feet long
- No plugs required, works in various pipe cross sections
- Flexible liner folds and bends easily for manhole entry
- Positive 45 minutes steam cure in hot or cold weather

Contact Erik Nielsen (770) 335-3201 for available territories, product information and pricing or submit request thru web site

www.AMerikSupplies.com

AMerik Engineering, Inc.
2600 Ainsley Ct., Marietta, GA 30066

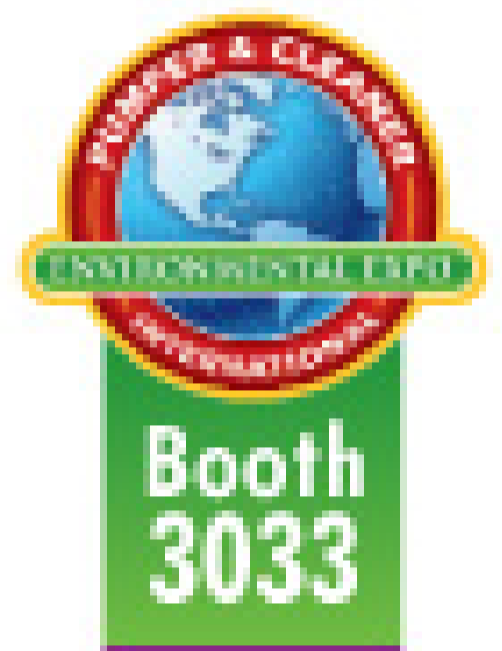

Ramps

I should have used a Link® Ramp!



- Reduce Injury \$\$\$
- Reduces Dangerous Lifting
- Protect Your Equipment

Do it RIGHT!

LINK®

Cargo Management Products

1-800-248-3057
www.linkcmp.com

Wolf Creek Co.

Original Bauer

Portable Piping

Bauer Fittings

Polybarb™ Pipe & Tails

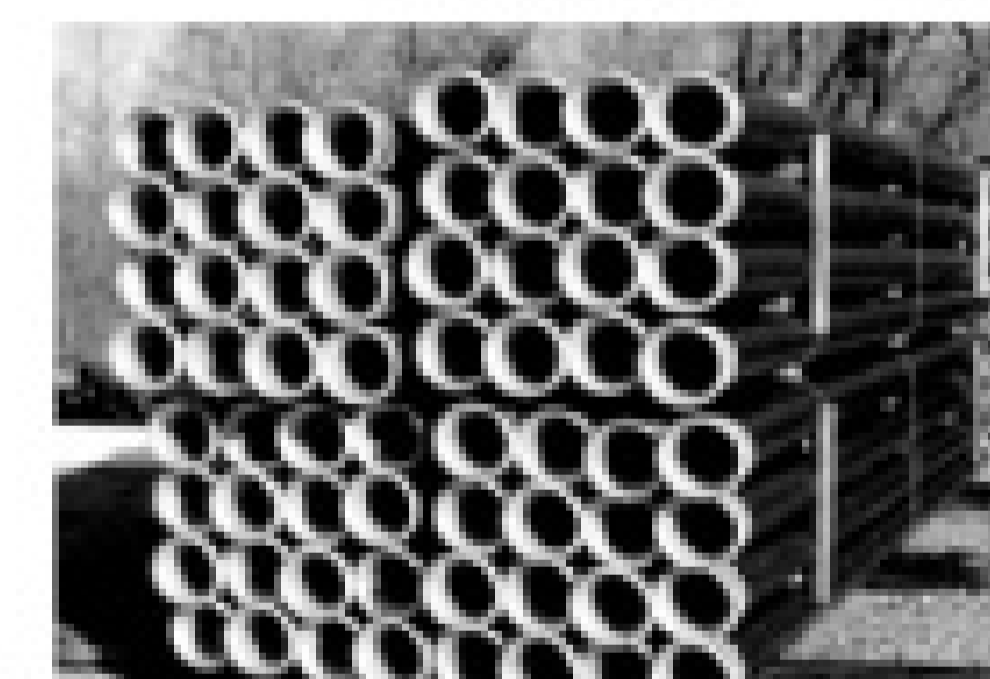

Polybarb™ HDPE pipes and fusible tails available in 4" to 12" diameters up to 40' in length.



Available in weldable, hose insert, and flanged connections. Fittings available from 2" to 12".

Industrial Vac Tubes

Bauer Pipe

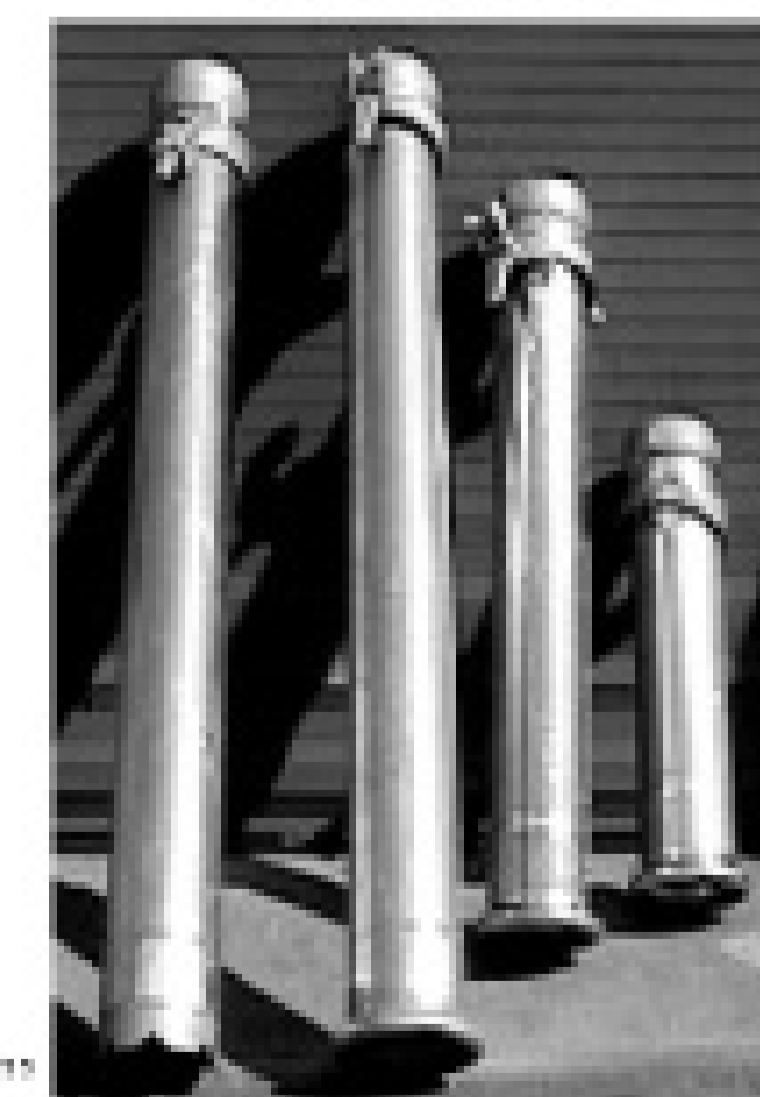

We can fabricate aluminum vacuum evacuation or suction tubes per your specifications. Using the Bauer Coupler or Anfor Coupler.



Galvanized piping available in 2" to 12"

800.488.7305 • www.wolfcreekcompany.com



Water Cannon Is A Convenient "One Stop Shop" For Pressure Washers, Engines and a Full Line of Parts & Accessories

27HP KOHLER Command - 3000PSI



- *15,000 Hour Rated Belt
- *Epoxy Powder Coated
- *Remote 6 Gallon Tank
- *Dual Shock Feet
- *Low RPM Pump
- *Twin Cylinder
- *Rental Duty
- *Plumbing Options Available
- *Lifetime Frame Warranty
- *15 Point Inspected

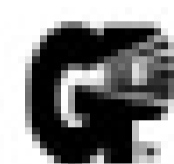

Part # 13H19
TSF Series
10.8GPM
\$4,129



Part # 13H16
660 Series
10 GPM
\$5,799

20HP GX 620 HONDA - 3000PSI

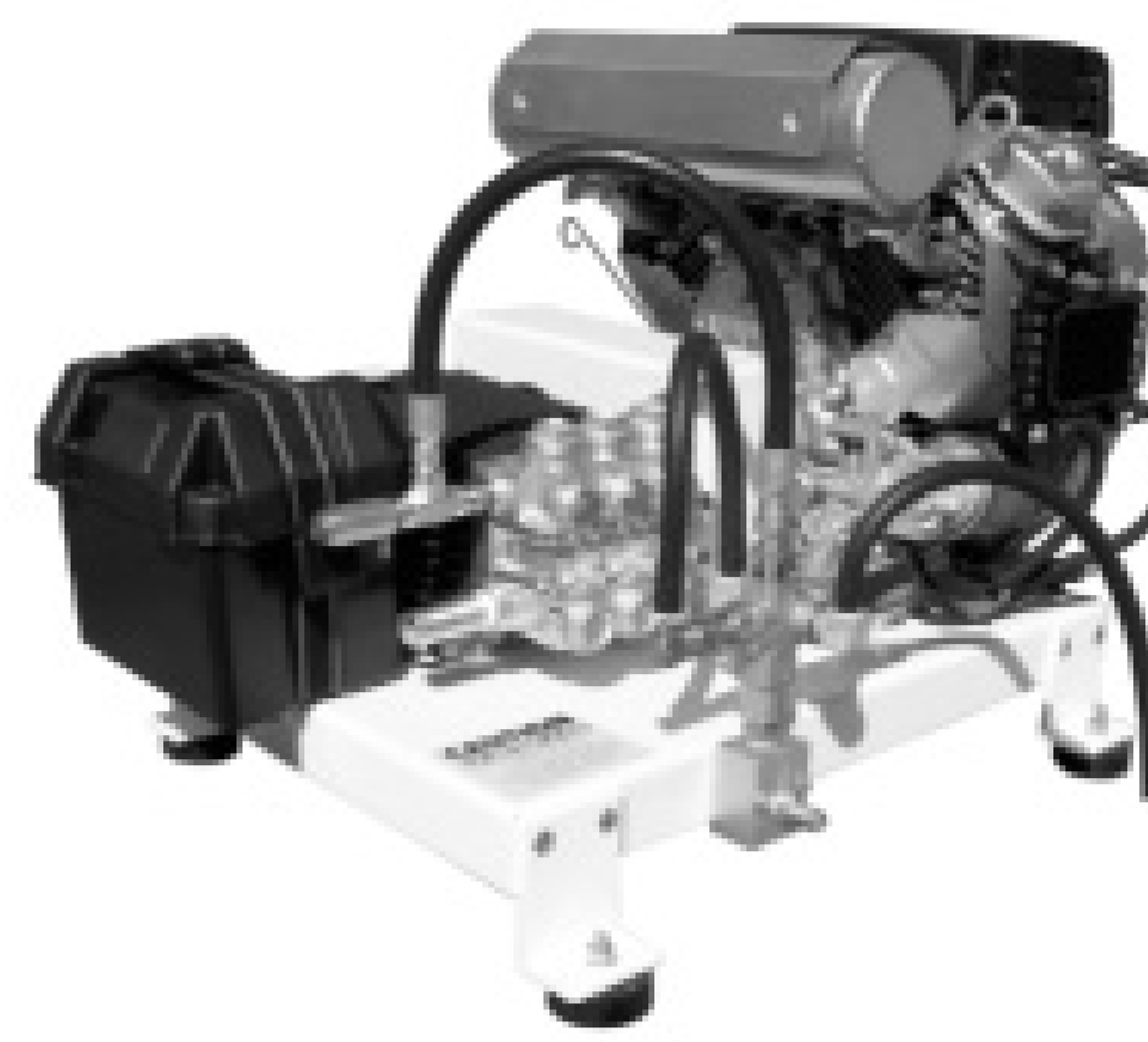

- *Industrial Features
- *Low RPM Pump
- *Electric / Key Start
- *Adjustable Throttle
- *Lifetime Frame Warranty
- *Tank Feed Inlet
- *We Customize
- *Overheat Protection
- *Jetter Versions Available
- *Specify Skid Mounted



Part # 13H13
TSF Series
8 GPM
\$2,999



Part # 13H10
XW Series
8 GPM
\$3,049



Mosmatic 21" & 30" Stainless Steel Surface Cleaners
Include A Spot Spray Wand & are Rated To:
250F. Deg @ 4500PSI Max.
See Online demo: www.watercannon.com

1-800-786-9274

Shop Online
www.watercannon.com
or Call for Fast, Friendly Service

27HP & 30HP KOHLER Command V-Twin - High GPM



- *15,000 Hour Rated Belt
- *Epoxy Powder Coated
- *Remote 6 Gallon Tank
- *15 Point Inspected
- *Industrial Features
- *Low RPM Pump
- *Electric / Key Start

- *Specify Skid or Wheels
- *Tank Feed Inlet
- *We Customize
- *Jetter Versions Available
- *Well Balanced - Low Vibration
- *Plumbing Options Available
- *Lifetime Frame Warranty



Part #13K08
TSF Series
12GPM @ 2800PSI
\$4,559



Part #13K05
1530 Series
15GPM @ 2000PSI
\$6,199

24HP GX 670 HONDA Twin Cylinder - High GPM - 3500PSI



- *Low RPM Pump
- *Twin Cylinder
- *Rental Duty
- *Plumbing Options Available
- *Lifetime Frame Warranty
- *Adjustable Throttle
- *Overheat Protection
- *Well Balanced - Low Vibration

- *Epoxy Powder Coated
- *Industrial Features
- *Electric / Key Start
- *Specify Skid or Wheels
- *Tank Feed Inlet
- *We Customize
- *Jetter Versions Available
- *Remote 6 Gallon Tank



Part #13H39
TSF Series
8GPM @ 3500PSI
\$3,249



Part #13H37
XW Series
8GPM @ 3500PSI
\$3,299

50' Super Kit



Includes: Chemical/Soap Injector
& 5 Color Nozzles

Part # 11564 **\$64**
Up To 4000PSI

Part # 11584 **\$84**
Up To 5000PSI

100' Deluxe Kit

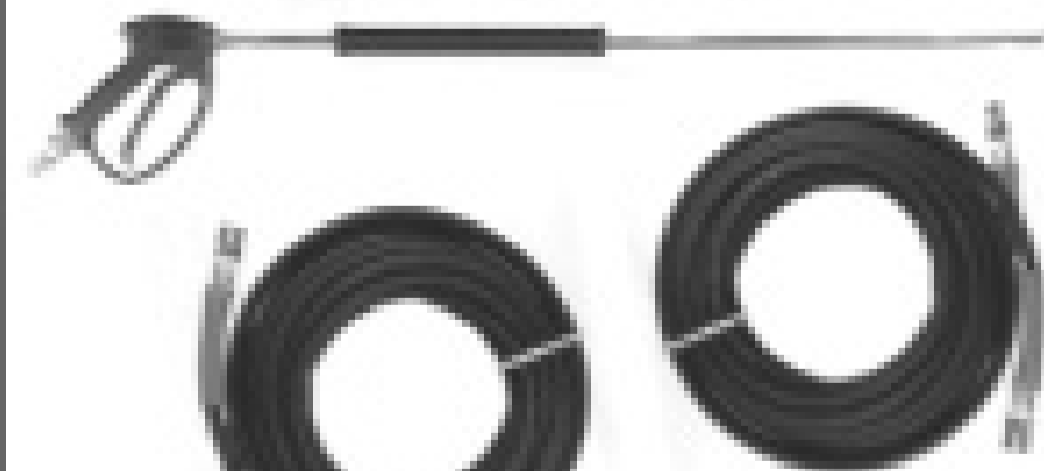

Includes: Chemical/Soap Injector
& 5 Color Nozzles

Part # 11109 **\$109**
Up To 4000PSI

Part # 11114 **\$149**
Up To 5000PSI

Imagine The Possibilities



1-800-454-9274

Whisper Wash



24" Part # 16715 **\$699**
28" Part # 15698 **\$729**
36" Part # 16865 **\$889**

New XD Series Up to 7000PSI



Talking Tech

Contractors describe how they have adopted technology and innovation to make their businesses more efficient, profitable and satisfying

By Mary Shafer

Bigger, better, faster, more – this has always been the promise of technology, whether in business or personal life. We've all noticed those long, white wires hanging down from people's ears to their iPods. And who could miss the phenomenon of rapid thumb movements on tiny keyboards as people text away to friends and colleagues?

But the real interest in business is how technology is moving the industry forward, helping contractors to do their jobs



Justin Mizell
Vice President
Sleuth Plumbing Technologies,
Sarasota, Fla.
 Employees: 20
 Years in Business: 16

more effectively. Here are some perspectives on innovations that people in the business have adapted to their everyday operations.

"We are a technology company," says Justin Mizell of Sleuth Plumbing Technologies in Sarasota, Fla. The firm does line location and televising, pipe bursting and relining on Florida's central west coast.

Every service it performs involves the latest technology. "We consider ourselves troubleshooters and problem solvers," says Mizell. "Camera work is the primary tool we use, and that leads to employment of trenchless technologies." Sleuth also uses GPS technology to track its trucks and create dispatch efficiencies in its fleet.

"We are a technology company. We consider ourselves troubleshooters and problem solvers. Camera work is the primary tool we use, and that leads to employment of trenchless technologies."

Justin Mizell
Sleuth Plumbing Technologies
Sarasota, Fla.

"We do a lot of line locating using our cameras and locators," says Chris Zabawa, owner of American Hydra-Jetting Service in Alvin, Texas.

"Just having those tools has made a big difference in our business. Before, you just kind of dug where you thought something was, and now we can locate something to within 2 inches.

We don't do plumbing, but we work for a lot of plumbers, and it has made a big difference for them."

It's also been a big benefit for customers, who are happy not to have a bunch of useless holes dug in their lawns. Zabawa also

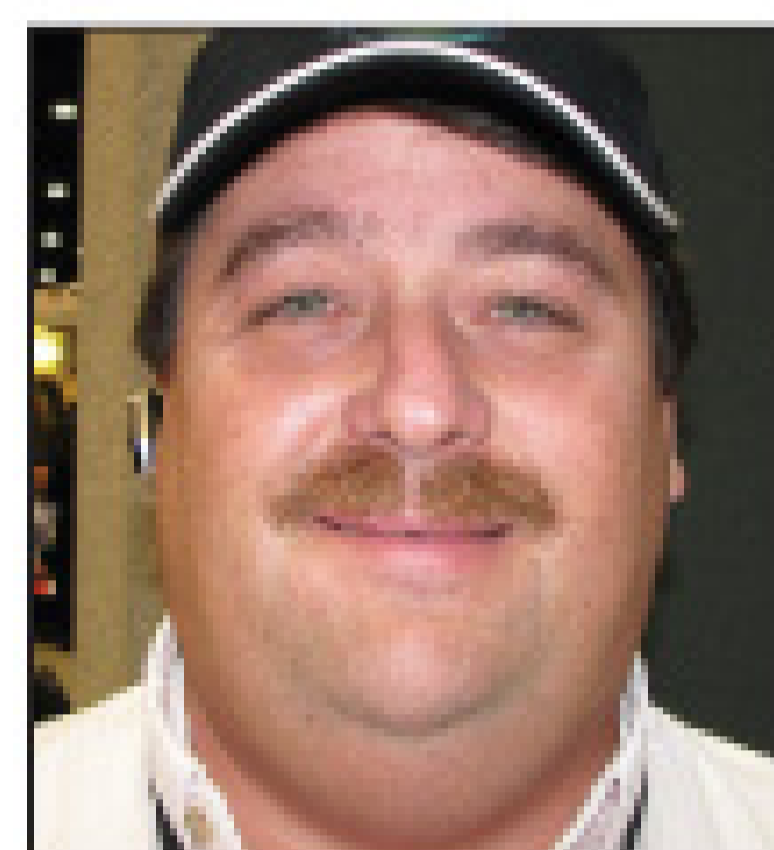

Chris Zabawa
Owner
American Hydra-Jetting
Service, Alvin, Texas
 Employees: 4
 Years in Business: 11

leans heavily on his Bluetooth cell phone earpiece. "It's for a wireless phone with Internet access," he says. "So now when I get an e-mail at the office, I can get it wherever I am. I don't have to be at the office.

"It's a shortened version of it, but at least I know I got it. Instead of just checking e-mail in the morning and the evening, I get it right now. Then I know if I need to contact the sender or not. Before, I'd have to tell people, 'Don't email me, I won't be there to check it.' Now I know." Though Zabawa's phone also has GPS capabilities, that's still one of the bells and whistles he hasn't used.

It's not so much new technology, but new ways of using existing tools that has made major inroads for the Gantt Sewer District's root intrusion program, according to director Mike Stansell.

"When I first came into the district, all they had was a standard mechanical root cutter," he says. "We were running nearly 50 stoppages per year on a 107-mile system." There were so many root problems that crews



Mike Stansell
Director
Gantt Fire, Sewer & Police
District, Greenville, S.C.
 Employees: 5
 Years in Business: 6

felt if they could get the camera through, the line was clean enough, and they'd just keep going.

Stansell looked at more modern ways to treat root intrusion and chose chemical foaming agents at first. However, the city wastewater treatment plant began to exhibit bacteria kills, and operators blamed the root treatment.

So it was back to the chain flails, but Stansell also researched and purchased improved versions

of that older technology. He also instituted a firm procedure of first televising each line for every job, no matter how small.

"When you use flails, you have to know what's in that line ahead of time," so the televising rule is critical, he says. Gas mains could be punctured and cause explosions, and high-voltage electric lines, if cut into, could kill the flail operators.

Aside from the safety considerations, this move ended up actually saving money. "The incremental investment of extra time to TV up front so increased our ability to continue standard maintenance that there have been three-month time spans with no calls after hours," Stansell says. "Our overtime rating is now running from 1.2 to 1.7 percent. It had been 5 percent."

Karl Pile, owner of Karl Pile Septic Service in Hagerstown, Md., is a veteran of more than a half-century in the business. He's been open to innovation from the start.

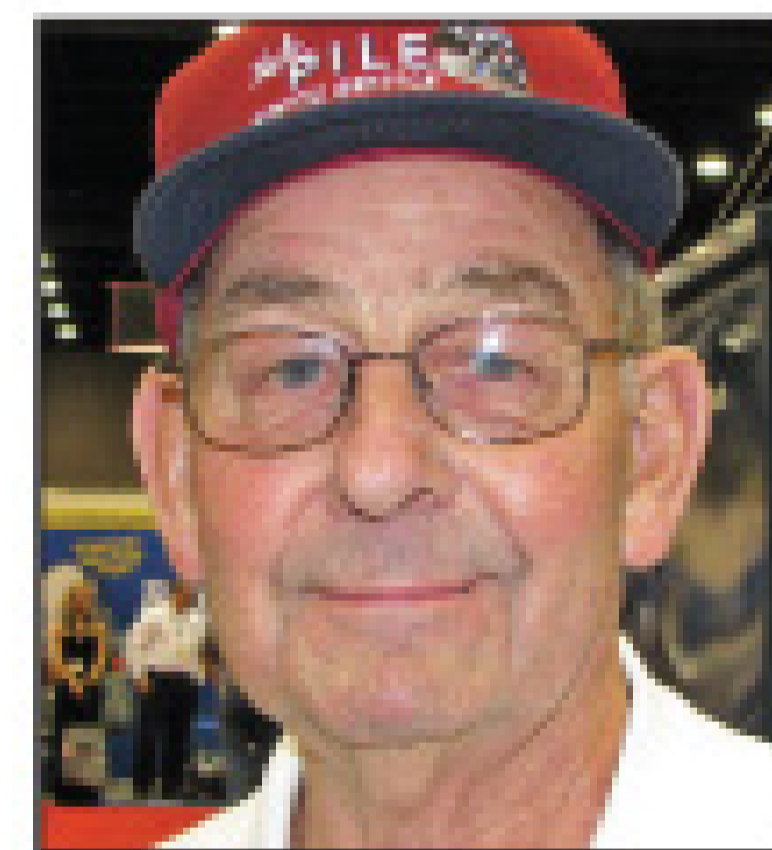

Karl Pile
Founder
Karl Pile Septic Service,
Hagerstown, Md.
 Employees: 3
 Years in Business: 54

"Even from the get-go, we started out with a built-up unit that used a surge milking pump for the vacuum," he recalls. "Then we came to find out that DeLaval pumps, with their 5-horsepower Briggs & Stratton engines, could create more vacuum, so we switched to that. The last truck we bought was a 2006 Sterling with a 2,500-gallon tank and 367 Jurop pump, the maximum. We've come a long way!"

The Pile fleet has benefited from most of the technological upgrades, including a few with GPS units. The business operations have remained fairly low-tech. "We still use manual billing and dispatching," Pile says.

Pile sees an encouraging trend in the industry that he believes is aided strongly by new technology. "Certainly, they're always talking about the environment, and you can see that people in the industry are environmentally inclined," he says. "That's why they're willing to pay the kind of money they are for the equipment they use to perform the service. It makes a mark, I think, on the general public to see that the industry can be very professional." ■

Comments may be directed to Mary Shafer in care of Cleaner. You may also e-mail pipelines@cleaner.com.



New Ridgid
Calendar **FREE**
With **\$500**
Purchase

It's easy to be cheaper. It's harder to be better!

OLDEST NAME IN THE BUSINESS
— Over 100 YEARS OLD —



NEW
SeekTech®
SR-60

NOW
AVAILABLE

RIDGID's new line of locating equipment meets the most demanding needs of the locating professional. Built to make even difficult locates easy, SeekTech is the only line locator that uses omni-directional antennas, guidance arrows and an easy to read mapping display to lead you quickly and accurately to the target line.

Parts & Service

Having Trouble

Finding

RIDGID Parts?

We Have

RIDGID Parts!



RIDGID®

THE BEST SERVICE AT PRICES TOO LOW TO LIST!

RIDGID®



SeeSnake

ALL SeeSnakes
NOW INCLUDE 512 HZ
TRANSMITTERS

DVD NOW
AVAILABLE
ON SEESNAKE
IN-STOCK

Factory Repair
for SeeSnake



SPECIAL PRICES ON THE NEW RIDGID SCOUT® IN STOCK!

Allan J. Coleman Co., Since 1905 - CALL US TODAY! 773-728-2400

"THESE PRODUCTS ARE SO GOOD, WE GIVE YOU OUR ADDRESS!"

5725 North Ravenswood Avenue • Chicago, IL 60660 • www.allanjcoleman.com

PHCC MEMBER

Flexible and Affordable Financing Options



Financing for New and Used Equipment:

Trucks	Tanks
Trailers	Toilets
Cameras	Jetters

also Computer Hardware & Software



7 Church Road Hatfield, PA 19440
Phone: 800.422.1844 Fax: 888.883.9380
Visit our website: www.libertyfg.com

COMMERCIAL EQUIPMENT FINANCING
CALL 800-422-1844

**Have It
Your Way**



Rent - Lease
Lease/Purchase

27" Late Model
Vac Trucks



Spectrum Industrial Services - (205) 664-2000 or Toll Free (888) 739-0838

It's A Bag Full



cleaner.com 

- > Classifieds
- > Truck Stop Ads
- > E-zines
- > Product Categories

**Come In
We're**

OPEN 24/7

www.cleaner.com 



**24 HOUR TURNAROUND - MIDWEST'S LARGEST FACTORY AUTHORIZED
REPAIR CENTER FOR GATORCAM, GEN-EYE & SEESNAKE**



SUPER SALE

Why wait
for the
Show?

Show
specials starting
NOW!

General J-2512 Typhoon™ Trailer Jet

Big cleaning power in a tough new package.



Blow away blockages in big lines and long runs. The Typhoon delivers 12 gpm at 2500 psi to blast lines clean of grease, sediment and debris.

- A 200-gallon holding tank carries enough water to handle remote applications where access to water is limited.
- 400 ft. capacity jet hose reel and 150 ft. capacity supply hose reel.
- Electric brakes, safety strobe light, rear fold-down stabilizer jacks, retractable hose guide arm, and antifreeze system

CALL FOR PRICING!

FREE DELIVERY

Compatible
with Electric
Eel® Connectors

- 1 1/4" x 8' - \$51.00
- 1 1/4" x 10' - \$56.00

**BUY
3 GET 1
FREE!**

Compatible with
Ridgid® Cables

- 5/8" x 7.5' - \$21.00
- 7/8" x 15' - \$43.75
- 1 1/4" x 15' - \$68.25

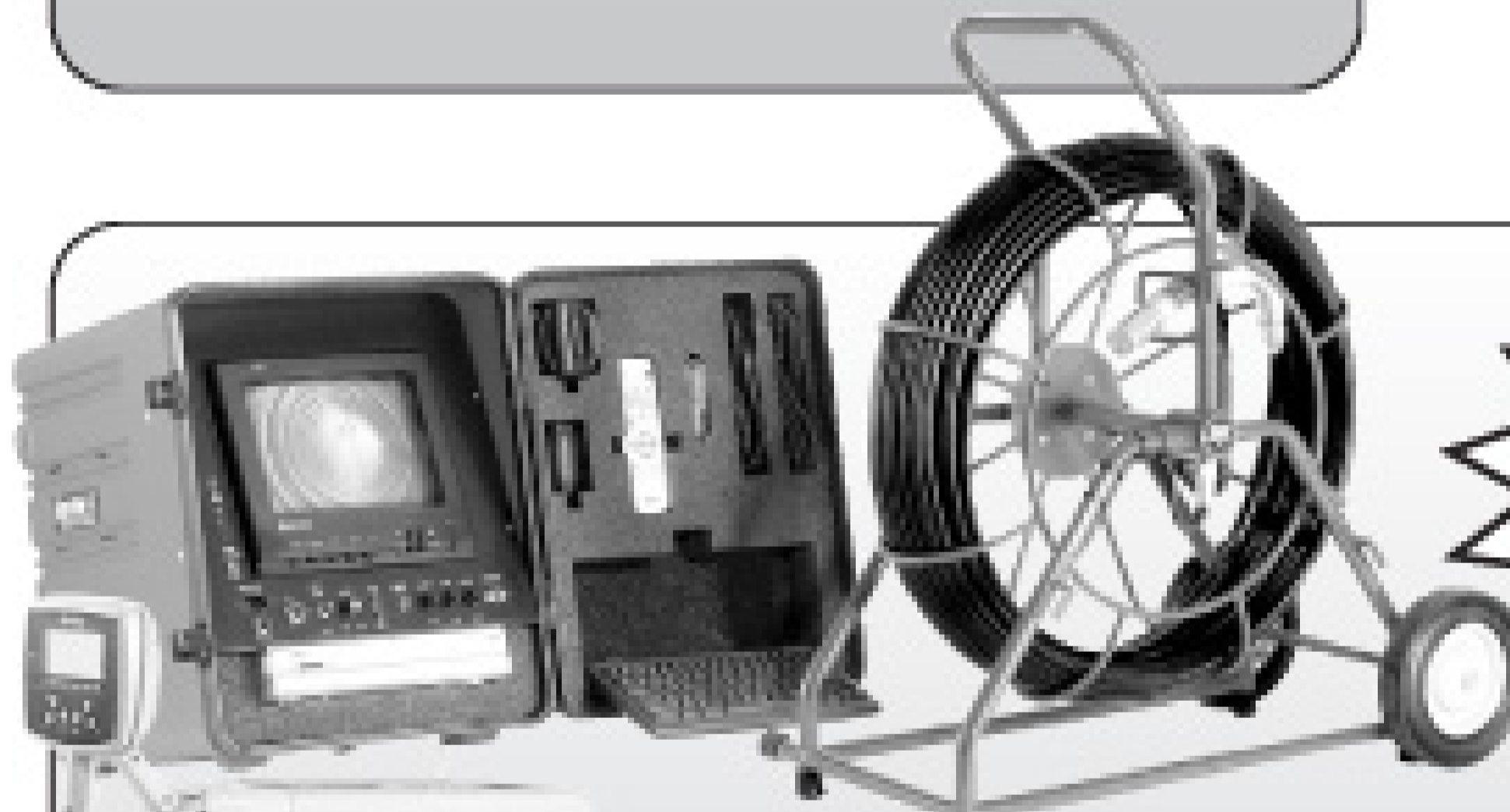

CALL FOR PRICING!

Gen-Eye GL™

Basic Unit Machine Only

- Self-Leveling color camera keeps the water at the bottom of the screen.
- DVD Recorder provides a crisp picture with jitter-free freeze frame.
- Gel-Rod® protects against moisture damage if rod is cut or abraded.
- Built-in full keyboard titler with eight pages of text easily shows your company name and job location.

FREE DELIVERY



Mini-Rooter XP™
Basic Unit Machine Only

\$485
FREE DELIVERY

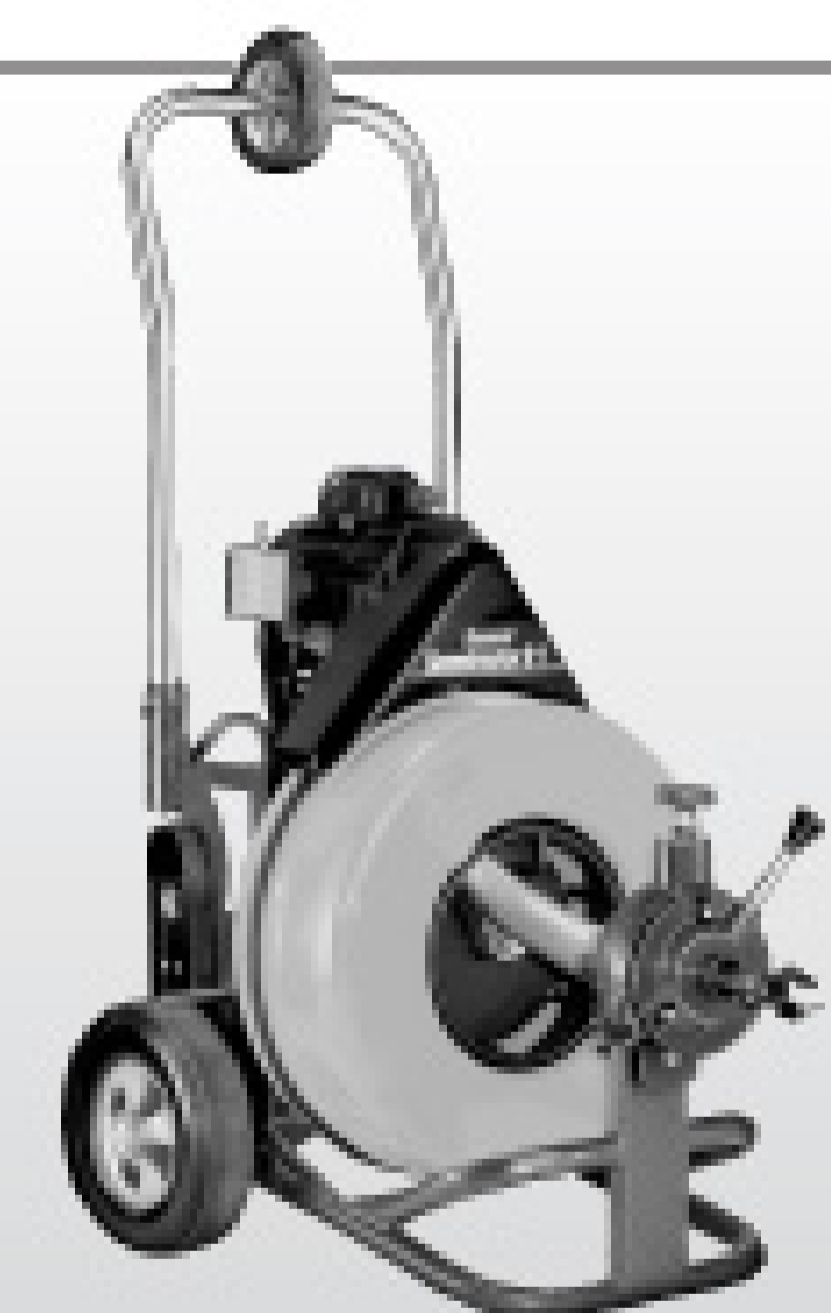

General Speedroter 91™
Basic Unit Machine Only

\$1010
FREE DELIVERY



Ever wonder why you keep “blowing” toilets and making all those little old ladies mad? We can show you how to avoid these “messy” situations, and clean more footage at the same time. Call KEG for help with your sewer cleaning tools before the news gets “splattered” all over town...not to mention all over your customers!

**Our Nozzles Don't Blow It
When Cleaning Your Sewer Lines!**

KEG Technologies, Inc.



Tel: 866.595.0515 Toll Free

The Difference Is Performance!

P.O. Box 3067
Madison, MS 39130

www.kegtechnologies.net

Head to Head - The World's Best HYDROVAC!



What do our customers say?

"No other Hydrovac even comes close to these trucks!"

- Northstar Hydrovac Inc.

"The Tornado F3 has outperformed any and all trucks that we've had in our fleet."

- Atlas Daylighting LLC

"Without question... the most cost-effective, productive and ultimate 'money-making' Hydrovac in the industry."

- Rockies Construction LLC



317-501-7577 • www.tornadotrucks.com



AVANTI
AvantiGrout stops leaks. Permanently.



Booth 7136

The most cost-effective way to seal laterals, mainlines, and manholes.

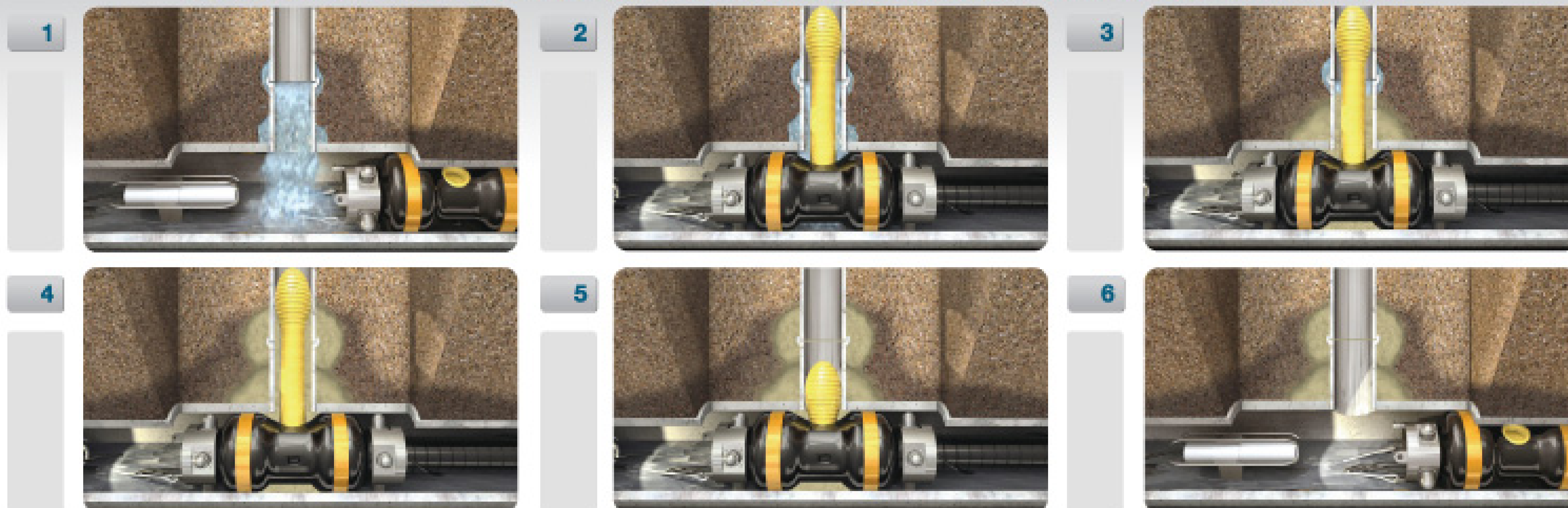

www.avantigrout.com // 800.877.2570 // 281.486.5600

One Complete Package

promonthly.com

cleaner.com

pumper.com

mswmag.com

onsiteinstaller.com

pumpershow.com

pumpertrader.com

eq-mag.com

tpomag.com

septicyellowpages.com

sewerpages.com

COLE Publishing

1.800.257.7222 | 715.546.3346

SOFTWARE FOR THE INDUSTRY



**Business Efficiency
...NOW more than ever!**

Summit™ XP Service Profit Builder™

Work Orders
Job History
Reminders
Diagrams
Dispatching
Instant Mapping
Inventory Control
Receivables
Automatic Credit Card Processing
Commissions
Repeat Business
QuickBooks® Link
...and much more!

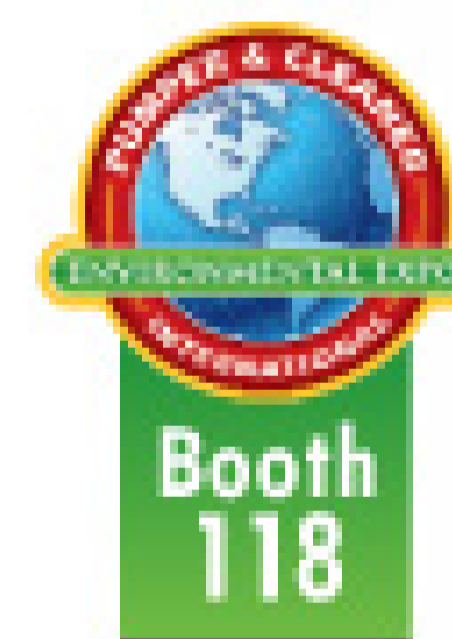

**Easiest to use!
...Over 25 years
experience**

*Let us transfer the data
from your old program!*

Stay on Top...with Summit™!

Ask about our other software programs for:
-Portable restrooms & other rental businesses
-Sales contacts for sales personnel
-Employee incentive tracking
-Fleet maintenance and service tracking

DEMOS ON LINE!...or call for a Demo DVD or personal guided tour



Ritam Technologies, LP

Sales: USA 800-662-8471 • Int'l: 208-629-4462
Email: info@ritam.com • Web: www.ritam.com

Fruit Cocktail

A multilayered poly resin liner enables a Pennsylvania food manufacturer to stop leaks and maintain production

By **Scottie Dayton**

A field stone and concrete settling tank at the Knouse Foods applesauce factory in Orrtanna, Pa., was severely deteriorated and cracked. Groundwater infiltrated and some commercial wastewater – an acidic slurry of diced apples, seeds, cores and water – exfiltrated.

The corroding tank was an ongoing problem, and maintenance supervisor Pat Balog didn't know what to do. Replacement wasn't an option, as the cost was prohibitive and the plant couldn't afford to lose two or more weeks of production.

At a trade show, Balog's plant engineer met Gary Mock of Advanced Rehabilitation Technology (ART) of Bryan, Ohio, who evaluated the tank and found it a candidate for relining with SpectraShield. The multi-component stress skin panel liner system from CCI Spectrum in Jacksonville, Fla., stops infiltration and prevents exfiltration. Its installation saved Knouse Foods some \$67,000 and kept the factory's applesauce production on schedule.

Preparation

Built in the 1930s, the 21- by 30- by 7-foot-deep outdoor settling tank is connected to the 5- by 8- by 7.5-foot-deep interior tank by a 24-inch-square opening. A smaller enclosure inside the outdoor tank filters wastewater before it flows into the larger settling tank. All tanks are uncovered.

The plant treats its own wastewater, and 25 percent of the volume was groundwater infiltration. Treated water is used for irrigation.

"The 12-inch-thick walls in the outdoor tank were eroded 4 to 5 inches, and the 6-inch-thick walls of the smaller enclosure were eroded 2 to 3 inches," says Mock. "I was amazed at the corrosiveness of apple juice."

Mock, Matias Garcia Jr., and Josh Kimple arrived on a Wednesday morning to prep the tanks. Balog used the opportunity to shut down two production lines for maintenance, and workers replumbed the wastewater from a third line to a backup tank. They also drained the



TOUGH JOB

PROJECT:

Clean and rehabilitate a settling tank before employees return from three-day weekend

CUSTOMER:

Knouse Foods, Orrtanna, Pa.

CONTRACTOR:

Advanced Rehabilitation Technology, Bryan, Ohio

EQUIPMENT:

SpectraShield liner system, CCI Spectrum, Jacksonville, Fla.

RESULTS:

Tank lined and online on schedule

settling tanks, then the ART crew loosened the solids on the bottom using the plant's fire hose.

CV Wenger Co., Chambersburg, Pa., service provider to Knouse Foods, was unable to pump out the slurry because of a water main break at another Knouse plant. Mock's crew couldn't start hydroblasting until the vacuum truck arrived the following morning. ART uses the trailer-mounted Model 40201D high-pressure Ultra-Clean water blasting system from NLB Corp. in Wixom, Mich.

Cleaning the tank using 6 gpm at 40,000 psi was a slow, laborious process. The men rotated shifts, as pulling the trigger on the hand-held lance asserted 80 pounds of pressure against their bodies. After two hours of fighting the tool, they were exhausted.

One corner of the interior tank was badly broken out and full of whole apples. The vacuum truck couldn't dislodge them until ART jettied the tank. By Thursday night, the men had removed all traces of applesauce.



Men and hoses went back and forth between the outside and inside tanks through this 2-foot-square opening.

28-hour day

Four inches of rain fell Thursday night, activating numerous leaks around the big field stones in the tank. "The surface of the walls must be dry before we can apply the primer," says Mock. "Most leaks were minor, but they were all over. We saw about two dozen."

Mock set up three heavy-duty high-performance livestock fans inside the tank to facilitate drying. To stop severe leaks, Garcia and



The first layer of the SpectraShield system was a primer designed specifically for saturated concrete.

Kimple bored into the walls and injected fast-acting SpectraGrout, but the drill bit kept encountering field stones. A direct hit stopped them cold. "Moving a few inches up or down sometimes got us around the rock," says Mock. "Other times, we probably were on the edge of one and forced our way through it."

Minor leaks were stopped with quick-setting hydraulic cement. The men applied the powder with their

The first layer of the SpectraShield system is a proprietary primer designed for saturated concrete. The thin film provides adhesion to the substrate. As Kimple sprayed it on, leaks returned through different outlets.

"That was our next big challenge," says Mock. "Work stopped while Junior or I plugged the leaks, then we'd look for new ones as Josh began spraying again. We'd know

"The 12-inch-thick walls in the outdoor tank were eroded 4 to 5 inches, and the 6-inch-thick walls of the smaller enclosure were eroded 2 to 3 inches. I was amazed at the corrosiveness of apple juice."

Gary Mock

gloved hands, and could feel the heat from the chemical reaction. Plugging one leak often forced the water down the crack and out another opening.

The 6-inch-wide by 5-foot-tall missing corner section in the interior tank was rebuilt using cement bricks for backing. "We used a lot of grout to plug severe leaks and the hydraulic cement to repair missing areas," says Mock. The repair took two hours, and stopping infiltration in all the tanks took seven hours.

Drying the walls of the interior tank was more difficult, too. As evening wore on, cool air formed condensate on them. The ART crew fought back with propane torches.

"The tank had to be online when employees returned from their three-day weekend," says Mock. "To meet that deadline, we worked from 8 a.m. Friday until the lining process was completed at noon on Saturday."

right away if something was wrong. The primer becomes runnier or has a milky appearance if water mixes with it or the surface is too wet."

The men and hoses went back and forth between the outside and inside tanks by ducking through that 2-foot-square hole. They fought excessive heat in the tank and fatigue, but took breaks to cool off, rehydrate and catch catnaps when possible.

Home stretch

After the primer dried the required four hours, Kimple sprayed on a 50-mil layer of silicone-modified polyurea followed by a 1/2-inch thick layer of tight closed-cell polyurethane foam to fill voids and restore placement. "Building back the eroded thickness wasn't necessary," says Mock. "We wanted a fair surface that looks good and cleans easily."



Two layers of sprayed-on foam sealers finished the tank restoration job. Matias Garcia Jr. applies a layer of polyurethane foam over the pink primer in the outside tank.

The foam dried tack-free in 8 to 12 seconds. Kimple then applied a second thin film of silicone-modified polyurea, which provided the final corrosion barrier and dried just as quickly. The tank was ready to go online. Balog gave the ART team free bottles of apple juice and asked Mock to evaluate another corroded concrete tank requiring cleaning and resurfacing. ■

MORE INFO:

CCI Spectrum
904/268-4951
www.spectrashield.com

NLB Corp.
248/624-5555
www.nlbcorp.com

PAT'S PUMP + BLOWER

ORLANDO OFFICE
800-359-7867
fax: 407-648-2096
GEORGIA OFFICE
800-851-7987
fax: 404-761-1300

#1 Pump And Blower Repair Specialist

< ALL YOUR NOZZLE NEEDS >

Ellipse Penetrator

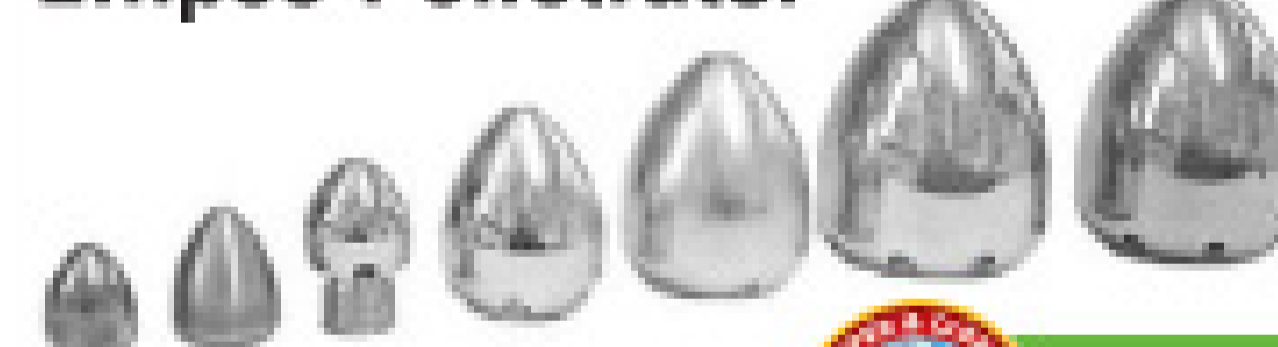

Vortex

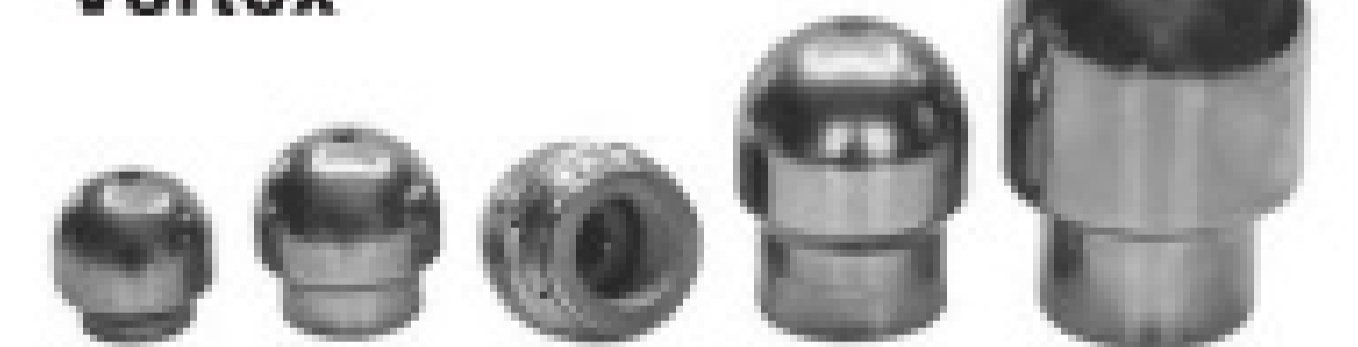

Chisel

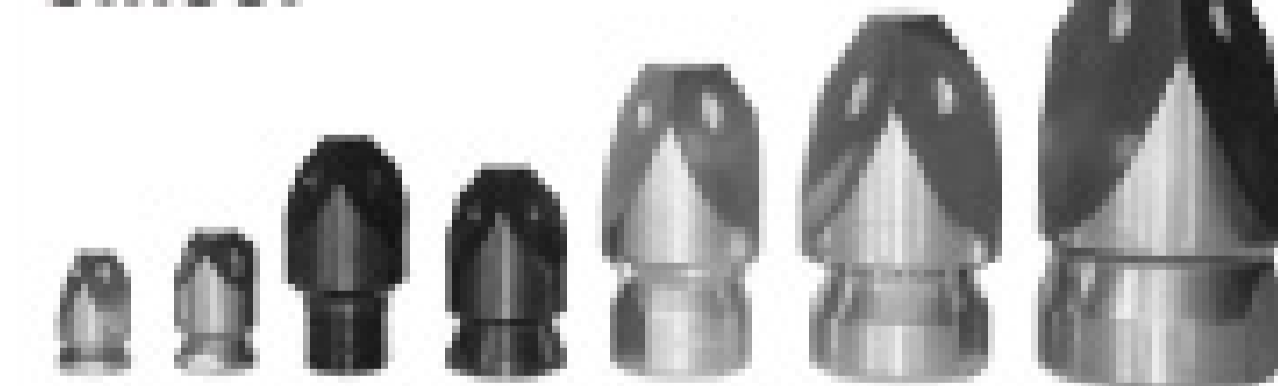

Propeller Cutter



Chain Cutter

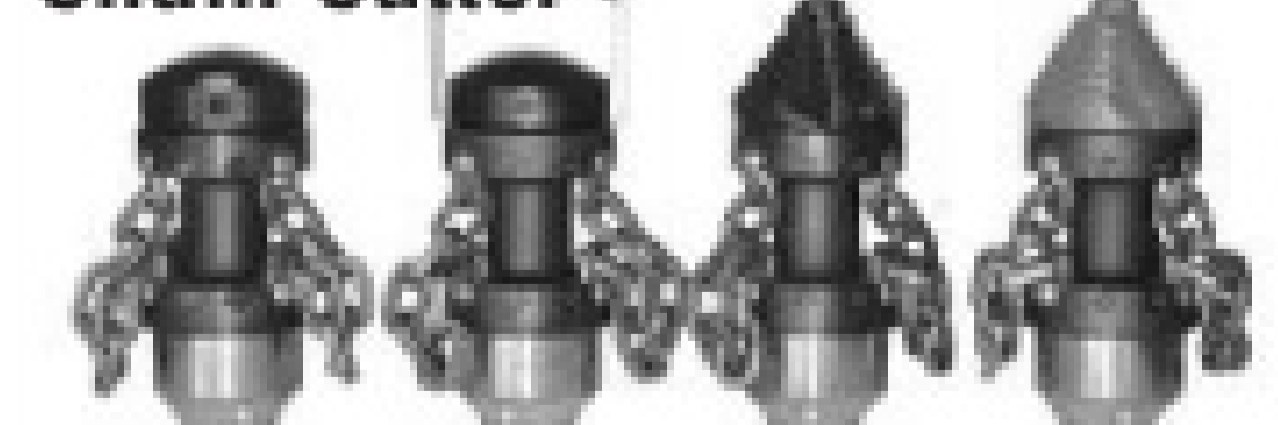

90° Swivel

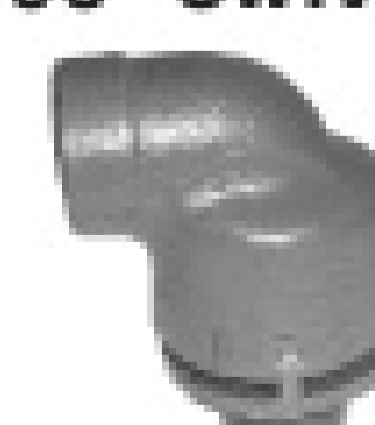

3-Way Ball Valves



RIGHT TOOL, RIGHT JOB, RIGHT NOW!

Call for catalog - Distributors wanted

www.patspump.com

Cleaner TRUCK STOP

see photos in COLOR at www.cleaner.com



1989 Sewer Equipment Jet Truck: Ford F800 chassis, 116K miles, 1,000 gallon tank, enclosed 60 gpm pump, pony motor and hose reel w/600' of 1" hose, new paint and parts.\$27,000

630-366-2480

P2C3



1997 Vac-Con Model V390THA: 71,000 miles, 8-spd. trans., 65 gpm, 2000 psi pump, 3-stage fan, hydrostatic drive, extendible boom, 600' of new jet hose, new white paint.\$57,500

Craig 714-639-8352

CFBM



1991 Camel 200: 6-speed, 65 gpm, 2000 psi, Roots 624 blower, tandem axel, ready for work, 169,000 miles, excellent condition.\$46,000

920-655-7302 or 920-866-9109

CBM



1993 Vactor 2110: 1994 Ford L8000 chassis, accumulator, centrifugal separator, telescopic/rotating hose reel, washout, loaded with options. Financing available. (Stk #1516)

Call Joe at 312-208-6373

C3



Shower and Restroom Trailers: Platinum and Gold Series, new and used available. Each with separate men and women sides.

CCI/Brian Touey 805-896-3777

CBM



3 Brand New TV Inspection Bodies: Heated/AC, flat panel monitor, sound mixer, VHS player w/monitor, air compressor, 12V water system, pressure washer, cable reel, winch, tool boxes, refrigerator, more!\$19,900 OBO

866-779-5438 or 603-491-8692

CM4



1986 Chevy C65 Cat: Diesel 175K, 5-speed manual split shift. New brakes and tires. Pump-Meyers D-65, 2000 lbs @ 65 GPM. One hour on rebuild. Perkins diesel. 1000 gallon tank. Good hoses and nozzles. Ready to work.\$25,000 (a steal)

770-527-0376

CFBM



2006 Safevac - Six (6) To Choose From: Sterling LT9511 chassis, MBE 460 engines, 27" Wispair blowers, OMSI transfer cases.\$165,000 Each

Call 1-888-739-0838

C3



(2) 1995 Ford L-8000, Vac-Con V-350: 8.3 Cummins 275 H.P., John Deere diesel upper, 600' 1" hose, telescopic boom, 3-stage blower, well maintained municipal trucks.\$29,900 Each

814-696-4343 - Hollidaysburg, PA

CMF3



Vactor Line Cleaner: 1986 Ford 8000, Cat diesel, Allison auto trans., fan drive with Ford gas pony motor. Runs and operates well. Located on West Coast. Can deliver.

209-339-1601;

209-810-8049 Mike

C3



2001 Vac-Con: Mounted on a 2001 Sterling LT7501 chassis. CAT 275 hp engine, 9-spd. trans., 109,500 mi., 20,000 lb. front axle, 40,000 lb. rear axle, 60,000 GVWR.\$95,000

Call Joey @ 904-284-2141

C3



2001 Vac-Con: Mounted on a 2002 Sterling LT9501 chassis. CAT C12 380 hp engine, 10-spd. trans., 139,800 mi., 20,000 lb. front axle, 44,000 lb. rear axle, 66,000 GVWR.\$95,000

Call Joey @ 904-284-2141

C3



1997 Ford: 300 hp w/Supersucker, 17" HG 1020 blower, wet/dry.

.....Asking Only \$50,000

For more information,
Contact Sergio at
361-318-4459

CM3



1999 IHC 2674, Vac-Con VPD-3116: ISM Cummins 400 H.P., Allison auto., 46 rears, 824 Roots blower, municipal truck.\$59,900

814-696-4343 - Hollidaysburg, PA

CMF3



Main Line Camera System: Including truck/office: RS Technical Omni III camera system, 1500' steel cable, 360° pan/tilt reverse mode, 2000 Chevrolet cargo box truck 14'\$54,900

Call Tom @ 412-922-6700

C3



2002 Camel Jet Vac: Sterling LT9500 chassis, 64K miles, 1300 gallon tank, 15-yd. debris, 80 gpm Meyers pump, 1,000' reel, Whip Air 27" PD blower. ..\$120,000

630-366-2480

P2C3

PLACE YOUR AD ONLINE AT www.cleaner.com - IT'S ALWAYS THERE TO MEET YOUR BUSY SCHEDULE

Cleaner. TRUCK STOP

see photos in COLOR at www.cleaner.com



2004 GMC Televising Truck: EXCELLENT CONDITION! Top of the line TV inspection vehicle. Includes Granite XP, camera, transporter and controllers. OPERATOR FRIENDLY & JOB-SITE READY!!.....\$80,000 OBO
Brian @ 708-745-1599 C3



Cues CCTV Inspection Van: Diesel, 16' box, Onan diesel generator, 53K miles, 2005 Kodiak Duramax.\$125,000
Bill Kendrick, 866-744-9921 CP3



2009 New Dewatering Filter Boxes: Complete roll-over tarp sys. w/wind guard, epoxy coated, 4" fill port, 3" drain ports, 6" wash-out ports, sealed tailgate, designed for hi-dump vac trucks. 15-yd. \$24,500; 30-yd. \$32,500. 550 gal. polymer sys. unit w/mixer, skid mounted, \$9,000.
Call for more info. 863-956-0315 CMP3



1994 Vactor GMC White Cabover: Cummins 6 cylinder x2, 1,000 gallons, 5 yards, dual fans, excellent condition.\$59,900
Contact Bill at 1-866-744-9921 CP3



2000 Sterling T/A Jet Truck: 4,000 gal. tank., 55,000 miles, 80 gpm, 3000 psi, new pump has 50 hrs., 500' of hose w/hp nozzle. Tank was cleaned and resealed in 2008.\$50,000
Contact Mike @ 765-914-9007 C3



1995 Mack CH613: E7, 350, spl. 10, 4500 gal., full DOT door, 300 water, jetter 12 gpm, 2,000 psi, 700 cfm, Demag, full tire tread.\$59,750
727-576-1111 CP3



2000 Pearpoint Pipeline Video Inspection: Color camera P494 pan/tilt, P599 drum, 1000', P420 tractor, recorder, P377 controller, 110V gen., fully self-contained, refurbished by Pearpoint, ex-city. \$34,500
Phil 562-926-5015 or 562-824-1093 CMP3



1999 Mack CH613: E7, 427, 13 spd., 4500 gal., full DOT door, 300 water, jetter 12 gpm, 2,000 psi, 700 cfm, Demag, full tire tread.\$69,750
727-576-1111 CP3



2006 Spartan Model 798 Trailer Mounted Sewer Jet: Rated at 4000 psi @ 18 gpm, 55.4 hours.Asking \$22,000
Call 1-888-739-0838 C3



Belt Press Semi Trailer Mounted: 2.0 meter press capable of producing cake sludge of 24% or more and up to 300 gpm, reversible load conveyors, twin polymer tanks w/mixers, polymer blend system, A/C control room w/complete cabinets. Unit is in show condition.\$165,000
863-956-0315 CMP3



1999 International: Cat C12, 10 spd. Eaton Fuller, Super Product 16-yd., 1,500 gal. water, 80 gal./min., Myers water pump. Dump body rebuilt, 624 Roots blower. Extras: Blower/2 Myers pumps.\$98,000 OBO
770-942-7446 C3



2001 Vac-Con: Mounted on a 2001 Sterling LT7501 chassis. CAT 275 hp engine, 9-spd. trans., 112,000 mi., 20,000 lb. front axle, 40,000 lb. rear axle, 60,000 GVWR.\$98,000
Call Joey @ 904-284-2141 C3

BE ONLINE AND IN CLEANER, MSW OR PUMPER

FOR ONLY \$125 PER PUBLICATION!

JUST GO TO WWW.CLEANER.COM, WWW.MSWMAG.COM or WWW.PUMPER.COM

AND FILL IN THE ONLINE TRUCK STOP FORM!

PLACE YOUR AD ONLINE AT www.cleaner.com - IT'S ALWAYS THERE TO MEET YOUR BUSY SCHEDULE

- ▶ Bucket Machines
- ▶ Businesses
- ▶ Business Opportunities
- ▶ Cable Machines
- ▶ Computer Software
- ▶ Dewatering
- ▶ Drainfield Restoration
- ▶ Drain / Sewer Cleaning Equipment
- ▶ Dredges
- ▶ Excavating Equipment
- ▶ Hazardous Waste Units
- ▶ Hydroexcavating
- ▶ Jetters-Trailer
- ▶ Jetters-Truck
- ▶ Jet Vacs
- ▶ Lease/Financing
- ▶ Locators
- ▶ Miscellaneous
- ▶ Parts & Components
- ▶ Pipeline Rehabilitation
- ▶ Portable Shower Trailers
- ▶ Portable Restrooms
- ▶ Portable Restroom Tanks
- ▶ Portable Restroom Trailers
- ▶ Portable Restroom Trucks
- ▶ Positions Available
- ▶ Positions Wanted
- ▶ Positive Displacement Blowers
- ▶ Power Washing
- ▶ Pressure Washers
- ▶ Pumps
- ▶ Pumps-Dredge
- ▶ Pumps-High Pressure
- ▶ Pumps-Submersible
- ▶ Pumps-Vacuum
- ▶ Pumps-Water
- ▶ Rodding Machines
- ▶ Roll-Off Containers
- ▶ Root Control
- ▶ Safety Equipment
- ▶ Septic Trucks
- ▶ Service / Repair
- ▶ Sludge Applicators
- ▶ Tanks
- ▶ Tools
- ▶ Trailers- Vacuum / Tanker
- ▶ TV Inspection
- ▶ Vacuum Loaders
- ▶ Vanes
- ▶ Wanted
- ▶ Wastewater Transfer
- ▶ Waterblasting

BUCKET MACHINES

USED BUCKET MACHINES, mechanical or hydraulic, parts and accessories. Call 416-248-4990. (CBM)

BUSINESSES

FOR SALE: 23-year-old restaurant service company specializing in hood system cleaning and ceiling restoration. Serving WV, OH and KY. Large loyal customer base. Grossing average \$500,000. All vans, equipment and experienced service techs in place. \$350,000. Will train. 304-372-2158. (CP7)

Very successful established Midwest based full service Trenchless Sewer Company with municipal and industrial experience and contacts available for acquisition. Serious confidential inquiries only. Please respond to P.O. Box 170053, Irving, TX 75017-0053 or email: cippcompany@yahoo.com. (CM4)

PORTABLE TOILET BUSINESS located in Albany, NY. 600+ units, 3 service trucks, 2 P&D trucks. 20 years family built business. Excellent growth potential. Call Stanley @ 518-441-7222. (CPT2)

BUSINESSES WANTED: Septic pumping, grease trap, drain cleaning and other ancillary businesses wanted. We are buying well run businesses in New England, Mid-Atlantic and Florida. All opportunities will be given proper consideration. Confidentiality ensured. Will move quickly for the right opportunity. Serious inquiries only. Please contact Richard Bedard @ Blue Water, 617-326-3344 or rbedard@bwseptic.com. (CPBM)

For Sale: DESERT SNAKE MANUFACTURING, a small drain cleaning business. We make snakes, manufacturing machines, cable manufacturing. Located in Phoenix, AZ. Call for details. 602-295-9198 Victor. (CBM)

IF YOU ARE USING AN
800 NUMBER

IN YOUR AD, BE SURE IT CAN BE USED IN ALL AREAS NATIONWIDE.

BUSINESS OPPORTUNITIES

If you are in need of a REGISTERED SEPTIC TANK CONTRACTOR to qualify your Florida-based septic company, send me an email @ BLRSepticService@aol.com or call 561-723-5001. (P4C5)

REDUCED! MUST SELL DUE TO OWNER'S HEALTH. Drain cleaning, jetting, plumbing business for sale in Myrtle Beach, SC. 3 trucks, jetter, all equipment. Strong customer base. Will consider holding plumbing license. Willing to train. 843-997-5570. (CBM)

WWW.ROOTERMAN.COM. Franchises available with low flat fee. New concept. Visit web site or call 1-800-700-8062 x26. (CPBM)

GREAT BUSINESS OPPORTUNITY: Quality manufacturer looking for independent representative or distributor to sell profitable consumable product to wastewater/collections market. Call 877-444-3549. (C3)

DRAIN/SEWER CLEANING EQUIP.

Rodder Truck (Sreco Flexible) 1990 Ford F450 w/123,000 miles, 7.3 L Diesel, auto tran, A/C, sectional rodder. Truck, tires and rodder motor in good condition, needs rod-ding segments replaced. Check website www.ziamunicipal.com for more information or call 614-419-4579. (CP5)

Used and rebuilt cable machines, cameras, water jetters and locating equipment. Ridgid K-7500, K-3800, K-1500, K-38, General Model Speed-roter, T-3, Mini Rooter, rebuilt Spartan #1065 - \$1400; #100 - \$650. The Cable Center. 1-800-257-7209. (CBM)

GLOVES

GLOVES brown jersey (100% cotton) 25 dz/cs, latex exam, shoe covers, sewer gloves, cotton, leather, PVC, welding. Any glove is available. Metro Industrial Supply 888-358-1923; www.easygloves.com. Visa/MC. Money back guarantee. (CP3)

JETTERS-TRAILER

1978 Myers trailer jet, Wisconsin gas engine, 300 gallon water tank, 500' 5/8" hose, new white paint. 515-864-1036. (C3)

SPARTAN 2000 798 TRAILER JETTER rated @ 4000 psi @ 18 gpm, new hose, always housed inside in heated building. Call for details. 630-554-3336. (CM4)

Pre-owned PipeHunter model 38T44 jetting unit, trailer mounted unit w/335 poly water tank, 4000 psi @ 25 gpm, 600' hose and attachments. In stock!!! (Stock #4313V) **www.VacuumSalesInc.com, (888) VAC-UNIT (822-8648).** (C3)

1987 Aquatech 600 gallon sewer jet trailer, excellent condition, Ford 4 cylinder gas, 35 gpm @ 1,800 psi, 500' of 3/4" hose. Good overall condition. 515-864-1036. (C3)

1999 O'Brien 3604 trailer jet. 600 gallons of water. 40 gpm @ 2000 psi. Root cutter kit and misc. nozzles. Continental gas engine. Call Jay Barnwell 1-315-437-1471. (C6)

2 SECA trailer jets. Both have Myers 35 gpm, 2000 psi pumps. New paint on both. Located in Dallas. 972-938-1905. **www.empireequip.com.** (CPBM)

New PipeHunter Model 38T44 jetting unit, trailer mounted, w/335 Poly water tank, 4,000 psi @ 25 gpm, 600' of hose and attachments. **In stock!!!** (Stock #13317) **www.VacuumSalesInc.com, (888) VAC-UNIT (822-8648).** (C3)

1981 FMC model 3530 trailer jet tandem axle, Ford 4 cylinder gas engine, 3/4" hose, 35 gpm @ 1,800 psi, good working condition. 515-864-1036. (C3)

2008 O'Brien 7040-SC trailer jet. 65 HP Cummins. 500' 3/4" hose. 700 gallon tanks. 40 gpm @ 2000 psi. Call Jay Barnwell 1-315-437-1471. (C4)

New O'Brien Model 3518-SC jetting unit, trailer mounted unit, w/350 poly water tank, 4000 psi @ 18 gpm, 400' hose and attachments. In stock!!! (Stock #3024V) **www.VacuumSalesInc.com, (888) VAC-UNIT (822-8648).** (C3)

JETTERS-TRAILER

For Sale: Aries Saturn 3 Camera System with cable reel mounted in a Cargo Sport Trailer, with overhead AC system. For additional cost, will include transporter and camera. Unit has shore power or generator. For more information, contact Woody Willis @ 904-219-6491. (CMP3)

JETTERS-TRUCK

2000 SECA water jet. Front mounted, hose reel, Myers 50 gpm 3000 psi, 1500 gallon plastic water tank. Was a city owned unit. In excellent condition. 714-639-8352. **www.empireequip.com.** (CPBM)

1996 Ford F800, Cummins 5.9L diesel, automatic, Underground model "Pipe Hunter" 500 gallon poly water tank, articulating hose reel, diesel auxiliary engine, 500' of 1/2" hose. Nice unit. 515-864-1036. (C3)

1995 Harben, 925 hours, in excellent condition, mounted on 1998 Ford F800, 5.9 diesel hydromatic, 500 gallon water tank. Asking \$21,000. In Florida. Call 561-740-2010. Cell 396-4469. (CP3)

1986 CHEVY C-65 Cat. Diesel 175K, 5-speed manual split shift. New brakes and tires. Pump-Meyers D-65, 2000 lbs @ 65 GPM. One hour on rebuild. Perkins diesel. 1000 gallon tank. Good hoses and nozzles. Ready to work. \$15,000 (a steal). 770-527-0376. (CMPBM)

1991 International 4700 DT diesel, 190 hp, 6-spd. manual trans., SA, hydraulic brakes, 1997 Sewer Equipment Company of America model 747 sewer cleaner, rotating hose reel, 500' of 3/4" hose, Perkins diesel auxiliary engine, 40 gpm @ 3000 psi pump. 515-864-1036. (C3)

2006 GMC TC6500 cab & chassis truck mounted jetting unit w/Jet Eye camera system, 3000 psi @ 50 gpm, 1000 gallons water, 600' hose, 500 cfm blower, debris tank and attachments. In stock!!! RENT ME!! (Stock #13234) **www.VacuumSalesInc.com, (888) VAC-UNIT (822-8648).** (C3)

PLACE YOUR AD ONLINE AT www.cleaner.com - IT'S ALWAYS THERE TO MEET YOUR BUSY SCHEDULE

JETTERS-TRUCK

2002 International 4900, DT-530, Allison MD3560P automatic, S/A, AB, air ride drivers seat, very nice SRECO FLEXIBLE truck mounted sewer jetter body, Myers pump, 65 gpm @ 2,000 psi, about 500' of 1" hose, 1,500 gallon poly water tank, only 20,700 miles and 2,210 hrs. on this unit. This is a very nice truck jet!! 515-864-1036. (C3)

1979 Ford F700, MYERS Truck Jet, SA, 370V4 gas engine, 5-speed manual, 2-speed rear axle, 40,000 miles, MYERS Model MHV-6-10L6 truck jet body, 65 gpm pump, 400' of 1" hose, Ford 6 cylinder gas auxiliary engine, new 900 gallon poly water tank. This is a very nice older jetter!!! 515-864-1036. (C3)

JET VACS

2001 Vac-Con Model V390 SHA, 3-stage fan, 80 gpm 2000 psi pump, 600' of new 1" jet hose, new paint. Was city owned. 972-938-1905. www.empireequip.com. (CPBM)

1991 International with a Vac-Con combination vacuum jetter unit. **www.VacuumSalesInc.com, (888) VAC-UNIT (822-8648).**(C3)

1994 Guzzler, Ford LNT8000, 126,250 miles, 275 hp, auto transmission, 9-cy debris tank, 16" Roots blower, Myers water pump, 2000 psi @ 80 gpm, 1500 gal. capacity, 8' extendable boom. Good condition. Reduced to \$62K OBO. 716-523-6813 after 5:00 pm. (CP3)

1998 Vactor 2110 on a Freightliner FL80, 28,213 miles, 2-stage fan, 80 gpm, 2,000 psi pump off system accumulator. Was a city owned unit. Located in Dallas. 972-938-1905. www.empireequip.com. (CPBM)

2003 Vac-Con VPD4216LHA, mounted on Sterling 9501, 16 yard, 800' hose reel, 1500 gal., 85 gpm/3000 psi, hydrostatic blower, clean good running truck. \$149,800. Call 561-718-2736. (C3)

VACTOR 1994 remanufactured Model 2115, 100 gpm @ 2,500 psi pump, two-stage fan. Many options. \$49,000. Call 440-352-9472 Cell 216-299-1396. (P3C4)

1996 Vactor Model 2110, **PD blower**, 65 gpm, 2000 psi pump, 10-yard debris tank, new paint. 972-938-1905. www.empireequip.com. (CPBM)

JET VACS

1995 Ford L8000, diesel, automatic, S/A, outstanding 5 cu. yd. Vac-Con combo unit, articulating hose reel, 500' of 3/4" hose, 3,000 psi @ 30 gpm FMC pump, 8" diameter front telescopic boom. Low miles and hours. Outstanding unit!!! 515-864-1036. (C3)

1999 Mack Camel, 65 gpm, 2000 psi, automatic, PD blower, extension boom, 32,000 municipal mi., well maintained. \$65,000. 585-248-6490. (CM4)

1998 Clean Earth, Ford Louisville, 136,900 miles, 275 hp, 10-speed Eaton Fuller, 10-cy debris tank, 27" Roots blower, variable speed Myers pump, 2000 psi @ 80 gpm, 1500 gal. capacity, 8' extendable boom. Also serves as a hydro-excavator. Good condition. Reduced to \$77,500 OBO. 716-523-6813 after 5:00 pm. (CP3)

1998 VacCon V312THA on a Ford LT8000, 3-stage fan, 65 gpm, 2000 psi pump, extendible boom, articulating hose reel, 12 yard debris tank, new paint. Was a city owned unit. Located in Dallas. 972-938-1905. www.empireequip.com. (CPBM)

1994 Ford LNT8000, diesel, automatic, tandem, 24,000 miles and 1,250 hrs., Vac-Con model V311THA combination sewer cleaning unit, 3-stage fan, 11-yd. debris body, 1,300 gallon water tanks 10' boom, articulating hose reel, hydrostatic drive, John Deere diesel auxiliary engine, only 1,600 hrs., 56 gpm pump. With fresh white body paint. 515-864-1036. (C3)

1986 Vactor 1200 on a Ford L-8000 w/3208 Cat w/Allison auto, 68000 miles. Pony motor, 6V53 Detroit w/4365 hrs. Body washout, recir. and anti-freeze systems. \$12,500. Jim @ 313-849-2667. (CP3)

1997 Clean Earth, Ford LNT 8000, 98,575 miles, 275 hp, auto transmission, 4-cy debris tank, 16" Roots blower, Myers water pump, 2000 psi @ 80 gpm, 2000 gal. capacity, 4' extendable boom, rear mount hose reel. Good condition. Reduced to \$47,500 OBO. 716-523-6813 after 5:00 pm. (CP3)

Looking for a couple late model Vectors with low hours. Please contact Steve @ River City Environmental, Inc. 503-969-7591. SteveM@rivercityusa.com. (CP5)

JET VACS

(1) 2002 Vactor 2110; (1) 2002 2115; (1) 2003 2110. **All PD units.** All were city owned units in excellent condition. Located in Dallas. 972-938-1905. www.empireequip.com. (CPBM)

1998 Vac-Con Model V350THA, 3-stage fan, 50 gpm, 3000 psi pump, 5-yd. debris tank, new white paint. Was city owned. 714-639-8352. www.empireequip.com. (CPBM)

1991 Camel 200, 6-speed, 65 gpm, 2000 psi, Roots 624 blower, tandem axle, ready for work, 169,000 miles, excellent condition. \$46,000. Call 920-655-7302 or 920-866-9109. (CBM)

CAMELS: 2008 Camel 200 DEMO unit, only 8,500 miles+/- . Like new with Cat Diesel, Sterling tandem chassis, 10 cy dump, front reel mount, winter circulation and vacuum excavating packages, never titled. 1997 Camel 200 on Ford LT8515 tandem chassis. One owner truck with only 67,000 miles, Cummins 275 Diesel, auto shift, 10 cy dump body and behind the cab reel. 1990 Camel 200 on a Ford LNT 8000 chassis w/a Ford Diesel, auto shift, 10 cy body, front reel and only 42,000 miles, municipal owner. Check website www.ziamunicipal.com for more information or call 614-419-4579. (CP5)

Jack Doheny Supplies Inc. offers a full range of late model combo units and DOT industrial vacuum loaders. Call us @1-800-3DOHENY. (CPBM)

LEASE/ FINANCING

North Star Commercial Credit: Commercial Loans for Trucks or Equipment. Flexible purchase programs to fit your budget. 21 yrs. in the industry. Contact **Tom Myers - 877-804-2274.** (CPBM)

MISCELLANEOUS

Top quality aerators at wholesale prices. We have replacement units for most name brands and also carry Linear Regenerative Rotary Vane pumps. Flagg Air, Gast, Thomas, FPZ, Secoh, Medo and more. Call a company that understands aerators and aeration systems. Septic Services Inc. 800-536-5564. (CPBM)

PARTS & COMPONENTS

Piranha Horizontal Hose Repair Machine (Swaging): 1- Vactor snorkel nozzle kit #50507, 1- O'brien root cutter with spiral blades 6", 8", 10" 1- Hydro Excavation tube and misc. Vactor parts. \$1,200 takes it all. Please call 802-948-2082. (C3)

US JETTING provides aftermarket rebuilding services and **replacement parts for Harben® pumps.** Low prices, fast response. Why pay more? Call today. 1-800-538-8464, ext 25 or 18. (CBM)

PIPELINE REHABILITATION

2008 UV Curing System - Reline pipes from 6" to 42" and 450' of cable with front & rear cameras. Chase is a Ford E450 with a 30 kilowatt generator. 250-962-9382. (C3)

Need plugs? Have seven 30"-60" flow through sewer plugs for sale. Brand new! Paid over \$6,500 US each. Make an offer! Kim 734-955-2508 x25. (C4)

Cues TV/Cutter Trailer: 2007 Evolution package, with or without camera, cutter or compressor. Call or go to our web site for photos and specs. www.mccannunderground.com. Financing available. Kelly 608-279-2299. (CBM)

One trade-in model of Pipe Genie heavy duty pipe bursting equipment. Excellent condition, looks new. 30-ton, 100 feet cable, full 2 year warranty. 877-411-7473. (CBM)

PORTABLE RESTROOMS

Portable Toilets: Poly constructed, molded seat, urinal, latching door. Handicap accessible units available. New and used. CCI/Brian Touey 805-896-3777. (CBM)

PORTABLE RESTROOM TRAILERS

Restroom Trailer - Gold Series: 32', new and used. Women's - 5 stalls, 2 sinks; Men's - 2 stalls, 2 urinals, 2 sinks. CCI/Brian Touey 805-896-3777. (CBM)

PORTABLE RESTROOM TRAILERS

Restroom Trailer - Platinum Series: 30', new and used. Women's - 4 stalls, 2 sinks. Men's - 2 stalls, 3 urinals, 2 sinks. CCI/Brian Touey 805-896-3777. (CBM)

PORTABLE RESTROOM TRUCKS

2002 International Pumper Truck: 4700 series, DT466, automatic, air brakes, 1200 gallon waste, 300 gallon fresh water, Masport 75 pump. CCI/Brian Touey 805-896-3777. (CBM)

POSITIONS AVAILABLE

SBP, Inc., a Northwest Florida-based company, is seeking qualified personnel willing to travel. If you are experienced in cured-in-place pipe lining, high pressure cleaning and video and/or manhole or lift station rehabilitation using epoxy lining systems, fax your resume to 850-478-4507 to the attention of Wanda Murphy. (C2)

Contractor seeking experienced employees to operate sewer cleaners, tv/grout/cutter, and Cured-in-Place Pipeline and Manhole equipment. Must have CDL, airbrakes, clean MVR and DOT. Most projects within 100 miles of St. Louis. Fax resume to 618-397-0098 or email: watincoffice@aol.com. (CM3)

PUMPS- SUBMERSIBLE

Wholesaler for Hydromatic, Zoeller, Myers, Liberty and ABS pumps. We also supply Grinder pumps and basins. Will help you size them. Septic Services Inc. 800-536-5564. (CPBM)

PUMPS- VACUUM

Complete line of Moro, Conde and engine-driven, stand-alone pump systems, DC10 washdown pump. Call us for any of your vacuum truck parts from shut-off valves, primary and secondary valves, hoses, vacuum pumps and drive systems. Septic Services Inc. 800-536-5564. (CPBM)

PUMPS-WATER

1 or 2 XT-8 pumps, 8", Model X-T8, 14 3/4" impeller, each with 40 hp 400 motors, less than 50 hrs. each. Also available control panels. \$7,500 each pump and motor. 727-576-1111. (CP3)

RENTAL EQUIPMENT

Liquid vacs, wet/dry industrial vacs, combination jetter/vacs, vacuum street sweeper & catch basin cleaner, truck & trailer mounted jettors. All available for daily, weekly, monthly, and yearly rentals. **VSI Rentals, LLC, (888)VAC-UNIT (822-8648) www.vsi rentalsllc.com.** (C3)

RODDERS

Nice Sreco trailer rodder, 20 hp Onan engine model NHB-MS 3604C, between 300' and 400' of rod. Very low hours. 515-864-1036. (C3)

1997 Chevrolet 3500 4x4 dually, 6.2L diesel, automatic, Sewer Equipment Company of America model 444 truck mounted sectional rodder sewer machine. About 52,000 miles. 515-864-1036. (C3)

SEPTIC TRUCKS

2004 International Model 4300 series, 2000 gallon Progress tank serial #20980, diesel, AC, Stereo/CD, power steering, 36,000 miles, original owner, want to sell ASAP. \$55,000 OBO. 818-912-1220. (CPTI3)

SERVICE/REPAIR

Sewer Cam Reel and Camera Repair: 48-hr. turn-around time. General Wire, Ratech, Electric Eel, Gator Cams. Quality service on all brands. For more info. give Jack a call. Dynamic Cable Repairs, Lodi, NJ 07644. 973-478-0893. (CBM)

www.servicewithasmile.com
Sewer Cam Reel and Camera Repair: Authorized for General Wire, Ratech & Ridgid. Quality service on all brands. Need more info? Give Chuck a call. Electronic Repair Co., Birmingham, AL 35206. 205-836-0454; email: part@servicewithasmile.com. (CBM)

SHOWER TRAILERS

Shower Trailer - Gold Series: 32', new and used. Men and women sides each have 3 private shower stalls with changing area, 1 restroom stall, 1 sink. CCI/Brian Touey 805-896-3777. (CBM)

SWEEPERS

2008 American La France Condor with a Vac/All Model VS10DC 3-in-1 machine (sweeper, catch basin, leaf collector), 350 water comp, 10-yr. debris body; vacuum system: 16,500 cfm belt drive with silencer, driven by Cummins turbo charged 6 cyl. diesel. In stock RENT ME!!! (Stock #1791) **www.Vacuum SalesInc.com, (888) VAC-UNIT (822-8648).** (C3)

TOOLS

T&T Tools: Probes, Hooks. Probes feature steel shafts with threaded and hardened tips. The insulated **Mighty Probe™** tested to 50,000 volts. **Top Poppers™** open manhole covers easily. Free catalog. **www.TandTtools.com.** Phone **800-521-6893.** (CPBM)

TRAILERS: VACUUM/TANKER

Dyna Vac Portable Grease Trap Svc. Unit. Hardly used unit, trailer mounted 200 gal. tank, 49 CFM vacuum pump and 115V elec. motor. Ramp and winch for easy loading/unloading and optional jettors. \$7,800 OBO. 518-885-7324; jimteneyck@aol.com. (CP3)

TV INSPECTION

New Cyclops Sewer Camera System mounted on 2001 Ford E-150 van. Heavy duty transporter, 500' cable, DVD recorder, keyboard data, LCD monitors front and rear, straight-view color camera. \$39,000. Or \$49,000 with pan/tilt camera. 830-249-9756. (C3)

Cobra Camera Truck: 2005 E450 Ford diesel. Contact service@jetplumbing.com for full pictures-details-price. Perfect condition. Sparks, Nevada. (P2CM3)

2008 Cues video/cutter truck, Cues OZII zoom camera with ultra shorty crawler, two Bowman Dominator cutters c/w control & Ridge power winch. 2006 GMC 16' cube van. 250-962-9382. (C3)

TV INSPECTION

For Sale: Cues Nite Owl pan and tilt camera in excellent condition. \$7,000 (CDN). 506-624-3993. (CP4)

Pearpoint TV Inspection Trucks: 1995, mounted in Isuzu NPR, turbo diesel, low miles, two cameras with small & large transporters, diesel generator, many extras. \$30,000. 559-276-0186. (CP4)

Used and rebuilt color and black & white camera kits. Ridgid SeeSnakes, General, Gen-Eye, Pearpoint. The Cable Center. 1-800-257-7209. (CBM)

Oceanquip sells Xtreme Green 12 conductor flexible cable & PUSH cables; connectors, pig-tails, assemblies for all major video tractor/cutter mfgers. Order from website: **oceanquipllc.com.** VISA & MC accepted. See us at P&C Booth 3031. (C3)

REBUILT INSPECTION CAMERAS: Gen Eye I, II, III. For more information call Jack at Dynamic Cable Repairs. 973-478-0893. (CBM)

2003 RST Ford Van 350, 67K, P&T Omni Eye 3 CD/DVD, Posom system, great cond. \$47,000 firm. Will train and deliver. Call David 214-536-2915. (C3)

TV INSPECTION BODIES, 3 available, **BRAND NEW,** dual compartment, heated/AC control rooms, LCD flat panel monitor, sound mixer, Panasonic VHS player with monitor, silent air compressor, Grundfos 12V water system, rear view camera, Karcher high pressure washer, motorized cable reel, GIS winch, multiple tool boxes, rear awning, refrigerator, and much more! Must sell, only 3 left, save thousands - **\$19,900 each or make a reasonable offer.** Bodies are in NH. Call 866-779-5438 or 603-491-8692 ask for Ron. (CM4)

EASYCAM COLOR CAMERA. FINALLY! A COMMON SENSE APPROACH TO CAMERA DESIGN. EasyCam requires no special monitor, all parts and components are owner-replaceable. With EasyCam, there is no more expensive repair costs, no more lengthy downtime. Built tough to last. 2-year guarantee. (US & Foreign Patent Pending) **ONLY \$3,950.00. EASYCAM - "It just makes sense." www.easycamlc.com; 1-423-349-4300.** (CBM)

TV INSPECTION

Cues Mainline inspection truck, 97 GMC 1-ton Savana with 68k miles. Pan & tilt camera, shorty transporter, DVD & VCR format, Cues studio design, with AC/heat, Honda generator and many extras. Sharp clean unit for sale. \$49,000. Call 319-759-7774. (C3)

14 'High Cube RST CCTV. Nice looking truck, 1990 GMC truck. Ready for work. Retrofitted 8 years ago. 40K original miles, Onan 65KW generator, OE3 pan & tilt camera tractor system, front & rear monitors & controls, work bench, tool boxes, Rhino covered floors. Many, many extras. Will accept the 1st offer over \$38,500. Excellent buy! Pictures via email. 541-396-6414, Oregon. (P2C3)

New Cyclops Sewer TV System mounted on raised roof Ford E-150 van. Pan & tilt camera, Crawler, 625 ft. cable, DVD, on-screen keyboard data. \$39,000. Call Bill 830-249-9756. (C3)

2002 Chevy 3500 CCTV Van: RST equipped with Wincan software, crawler with pan and tilt camera, stainless single conductor, Honda generator, 76,000 miles. \$55,000 OBO. 412-221-1113. (C3)

Refurbished Cyclops sewer TV camera van. Pan/tilt camera, crawler, 530' cable, screen footage, VCR. Mounted on Ford Aerostar minivan. \$22,500. 830-249-9756. (C3)

Pads and Chain Assemblies: Silicon carbide filled for maximum traction and long life. Single and double hole pads for all makes of tractors. Money back guarantee. Contact **Pipe Tool Specialties** (503) 1-888-390-6794 or fax 1-888-390-6670. Samples sent upon request. Same day shipping. We are a 6/12 company. (CMBM)

Wanted: Used tractors, crawlers, straight-pan/tilt cameras, lighthoods, power controls, cables, reels, monitors, software, etc. Working or not. 902-435-8200, fax 902-435-8222. (CBM)

VACUUM LOADERS

1986 IME Model trailer mounted sewer vac, 20 hp Onan engine model NHC-MS 3888D in very good condition with only 500 hrs. 515-864-1036. (C3)

2007 6027 Supersuckers: Mounted on 380 HP Sterling Cat chassis, low hours and miles. \$190,000. Call Mike 219-398-4000 or 888-551-1998. (CP3)

WANTED

WANTED: Ridgid K-7500 machine, working or not. Call 651-492-8699. (CP3)

Wanted to Buy: Vactor 2100's and late model Guzzlers. Cash. 800-336-4369. (CPBM)

WATERBLASTING

Gardner Denver 620-671 Detroit 20K @ 11 gpm. **Gardner Denver** IL450- Volvo 20K @ 17 gpm. **Aquadyne** GA 200 variable speed 3116 CAT 20K, 20 gpm. **Aquadyne** 0450DS-Cummins 20K @ 36 gpm. **Jetstream** 4220-Cummins 20K @ 17 gpm. **Jetstream** UNX-6V53 Detroit 10K @ 26 gpm. **NLB-Ultraclean** Cummins 36K, 7 gpm. **NLB** 10-600 Cummins 10K @ 104 gpm. **NLB** 5-250 Cummins 3600 psi, 182 gpm. **US Jetting Sewer Unit** 4K @ 14 gpm. **Boatman Ind. 713-641-6006. View @ www.boatmanind.com.** (CPBM)

2002 NLB-4075D diesel, 40,000 psi, 3 gpm, trailer mounted, 300' new hoses, 620 hrs. Perfect condition. Price \$45,000. Contact 973-476-7194. (CP6)

2001 Vactor Vaxjet, closed loop surface cleaning system, 10,000 psi, 1000 gal. tank. Call for details. \$160,000 OBO. 330-270-9900 ext.109. (P2C3)

NLB 860E, 2 units, 3000 hr. ea. 12.5 gpm @ 8k, also NLB 812 trailer w/453 Detroit. All units excellent. \$12,000 ea. 262-783-8100. (P2C3)

Water jetting equipment. We rent, sell and repair water blasters. Visit us at: www.waterjettingequipment.com or phone 714-259-7700. (CPBM)

2005 NLB 40K 40201, excellent condition. \$75,000. Call for details. 330-270-9900 ext. 109. (P2C3)

06 Jetstream Hydroblaster, 172 hrs., 10k, 15k, 20k. Hydraulic hose reel with 500' of 10K hose (new). Mounted in a custom 28' enclosed gooseneck. Long list of lances, nozzles, etc. \$96,750. 605-886-4225. (M3C4)

Sapphire nozzles for all major 40,000 psi waterblasters at wholesale prices! Same-day shipping. UHP replacement parts, hoses. waterjet@bell.south.net, 772-286-1218. (CBM)

Get Results!

Advertise in **CLASSIFIEDS** for only

\$1.00 per word!
(\$20 min.)

**MUNICIPAL
SEWER
&
WATER**

Cleaner

Pumper

CLASSIFIED AD FORM

PRO

**ONSITE
installer**

Please print ad legibly below with *correct punctuation* and *phone number*. Circle each word to be bolded, if any. (\$1.00 extra per word)

CHOOSE THE CATEGORY:

- | | | | | | |
|--|---|---|--|---|---|
| <input type="checkbox"/> Aerators | <input type="checkbox"/> Dredges | <input type="checkbox"/> Levels & Transits | <input type="checkbox"/> Positions Wanted | <input type="checkbox"/> Root Control | <input type="checkbox"/> Trailers- Vacuum/Tanker |
| <input type="checkbox"/> Blowers | <input type="checkbox"/> Excavating Attachments | <input type="checkbox"/> Locators | <input type="checkbox"/> Pressure Washers | <input type="checkbox"/> Safety Equipment | <input type="checkbox"/> Trucks (dump/septic/misc.) |
| <input type="checkbox"/> Bucket Machines | <input type="checkbox"/> Excavating Equipment | <input type="checkbox"/> Miscellaneous | <input type="checkbox"/> Pumps-Dredge | <input type="checkbox"/> Septic System Components | <input type="checkbox"/> TV Inspection |
| <input type="checkbox"/> Businesses | <input type="checkbox"/> Hand Tools | <input type="checkbox"/> Parts & Components | <input type="checkbox"/> Pumps-High Pressure | <input type="checkbox"/> Septic Tanks | <input type="checkbox"/> Vacuum Loaders |
| <input type="checkbox"/> Business Opportunities | <input type="checkbox"/> Hazardous Waste Units | <input type="checkbox"/> Pipeline Rehabilitation | <input type="checkbox"/> Pumps-Submersible | <input type="checkbox"/> Septic Trucks | <input type="checkbox"/> Vanes |
| <input type="checkbox"/> Cable Machines | <input type="checkbox"/> Hydroexcavation | <input type="checkbox"/> Portable Toilets | <input type="checkbox"/> Pumps-Vacuum | <input type="checkbox"/> Service/Repair | <input type="checkbox"/> Vehicle Tracking |
| <input type="checkbox"/> Computer Software | <input type="checkbox"/> Jetters-Trailer | <input type="checkbox"/> Portable Toilet Tanks | <input type="checkbox"/> Pumps - Washdown | <input type="checkbox"/> Slide-In Units | <input type="checkbox"/> Wanted |
| <input type="checkbox"/> Dewatering | <input type="checkbox"/> Jetters-Truck | <input type="checkbox"/> Portable Toilet Trailers | <input type="checkbox"/> Pumps-Water | <input type="checkbox"/> Sludge Applicators | <input type="checkbox"/> Wastewater Transfer |
| <input type="checkbox"/> Drainfield Restoration | <input type="checkbox"/> Jet Vacs | <input type="checkbox"/> Portable Toilet Trucks | <input type="checkbox"/> Rodding Machines | <input type="checkbox"/> Tanks | <input type="checkbox"/> Waterblasting |
| <input type="checkbox"/> Drain/Sewer Cleaning Equip. | <input type="checkbox"/> Lease Financing | <input type="checkbox"/> Positions Available | <input type="checkbox"/> Roll-Off Containers | <input type="checkbox"/> Tools | |

CHOOSE THE PUBLICATION(S): (Deadlines are for the month preceding issue)

- | | | |
|---|---|--|
| <input type="checkbox"/> CLEANER
Deadline: 1st of the Month | <input type="checkbox"/> PUMPER
Deadline: 10th of the Month | <input type="checkbox"/> PRO
Deadline: 17th of the Month |
| <input type="checkbox"/> MUNICIPAL SEWER & WATER
Deadline: 1st of the Month | <input type="checkbox"/> ONSITE INSTALLER
Deadline: 17th of the Month | |

CLASSIFIED AD RATE:

\$1.00 per word, per month, with a 20-word minimum or \$20.
[\$1.00 extra per bold word (key words only)]

ADVANCE PAYMENT REQUIRED:

No billing for classified ads. Payment must be received in advance before publishing.

CALCULATE THE AMOUNT DUE:

_____ words X \$1.00 = _____ X _____ Publications X _____ Months = \$ _____
(\$20 minimum) # of publications checked above # of months to run the ad Total Amount Due

(Example: 25-wd. ad x \$1.00 per word = \$25.00;
\$25.00 x 2 publications [Pumper & Pro] = \$50.00;
\$50.00 x 2 months to run the ad = \$100.00 Total)

FILL IN COMPANY AND PAYMENT INFO:

COMPANY NAME: _____
 ADDRESS: _____ PHONE: _____
 CITY: _____ STATE: _____ ZIP: _____

MAIL this completed form with payment to:
COLE Publishing Inc., PO Box 220, Three Lakes, WI 54562

FAX this completed form to: **715-546-3786**

ONLINE forms at: www.cleaner.com
www.pumper.com
www.promonthly.com
www.onsiteinstaller.com
www.mswmag.com

QUESTIONS: CALL 1-800-257-7222

PLEASE FILL OUT CREDIT CARD INFORMATION COMPLETELY INCLUDING V-CODE (3-DIGIT NUMBER FOUND BY YOUR SIGNATURE)

CREDIT CARD NO.: _____ V-CODE: _____ EXP. DATE: _____

CARDHOLDER NAME: _____ PHONE: _____

WE ACCEPT:

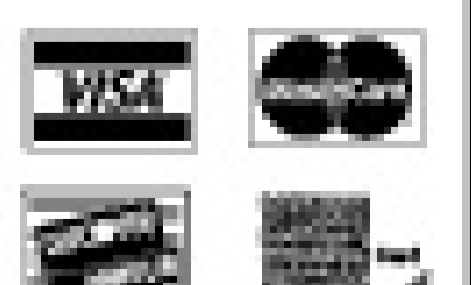

Marketplace Advertising



PIRANHA
HOSE PRODUCTS

Booth 3093

- PIRANHA® JETTER HOSE
- STAINLESS NOZZLE TIPS
- SEWER HOSE GUIDES
- SWIVELS & ADAPTERS

ONE CALL AWAY...

CAPITAL RUBBER CORP
(800) 258-3000

WWW.CAPITALRUBBERCORP.COM

Sewer Cam BROKEN?

> We service push rod reels, cameras and command modules. We repair most brands. We are an authorized service center for General Wire, Ratech, Vision and Ridgid.

> We understand when your equipment is broken, you are losing dollars! We give fast and quality service.

Electronic Repair Co.

8518 First Ave. N., Birmingham, AL 35206 • 205-836-0454
part@servicewithasmile.com • servicewithasmile.com

Sewer Camera



\$1,095
Free Freight

Drain Snake



\$329
Free Freight

Jetter Package



\$1,499
Free Freight

COMPLETE DETAILS AT
www.AmazingMachinery.com
1-800-504-7435

CLEAN MORE FOR LESS

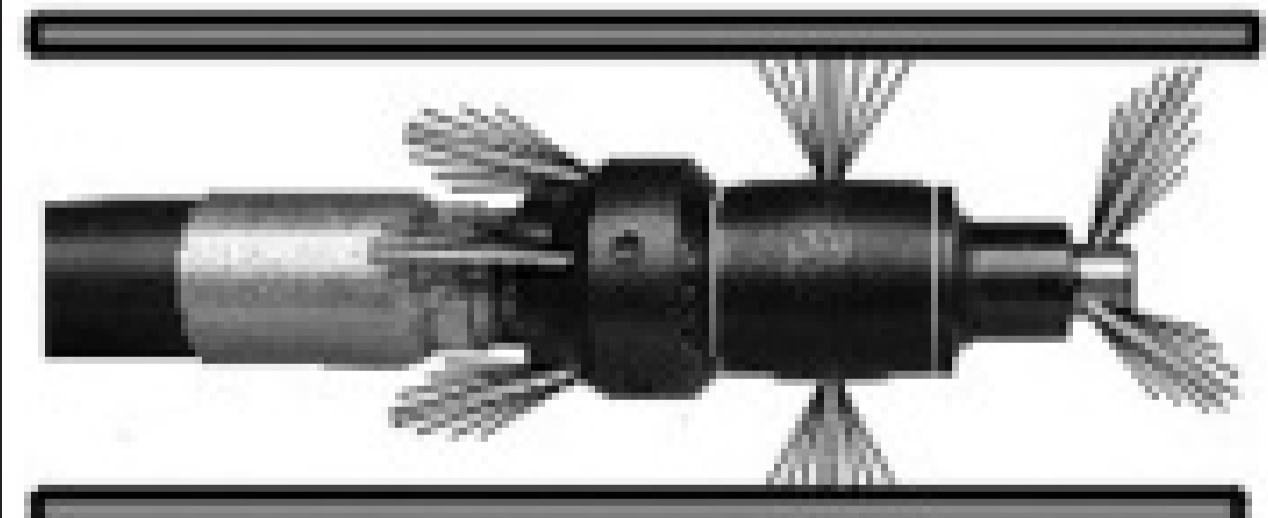

The "Hydro Tornado" Revolving Sewer Nozzle

- 3 Interchangeable forward jets
- 2 Revolving Jets
- 5 Rearward Jets
- 5 Thread Sizes available
1/4" 3/8" 1/2" 3/4" & 1"
- Available from 3 thru 80 GPM

Call for prices or see our complete line of nozzles, skids and root cutters on the web at

www.breakthrumfg.com

Call Toll Free 1-866-415-4655

Break Thru Manufacturing
P.O. Box 87893
Canton, MI 48187

ALMETEK SEPTIC MARKERS



A GREAT WAY TO
**ADVERTISE &
GROW YOUR
SEPTIC BUSINESS**

ALMETEK'S Septic Markers Will:

- Be a "silent salesman" to increase your business
- Project a professional image
- Distinguish you from your competition

CALL TOLL FREE FOR MORE INFORMATION

1-800-248-2080

ALMETEK INDUSTRIES INC.

2 Joy Drive Phone: 908-850-9700
Hackettstown, NJ 07840 Fax: 908-850-9618
www.almetek.com

Booth 176

\$2,999

Confined Space Entry System

- 7' Tripod
- 3-Way Fall Winch
- Work Winch
- Full Body Harness
- MSA Altair 4 Gas Monitor

Call for Catalog & Prices
Cloverleaf TOOL CO. 800.365.6583
www.cloverleaftool.com

Come In
We're

OPEN

www.Cleaner.com

Waterblaster Rentals

Houston, Texas



Booths 6171

Boatman Industries

1K to 50K psi
60 hp to 1000 hp
Waterblasters & Accessories
Used Equipment Sales

713-641-6006

www.boatmanind.com



Every business owner needs advice. I find all I need in just one place.

Let's face it: One person can't know everything. When I need help, I turn to friends I've met at the Expo. My competitors? They just struggle along on their own. It's almost unfair! Extend your hand and meet someone new.

Have you seen the Cleaner E-Zine?

Go to cleaner.com to view the e-zine.

DYE TRACERS

Solutions for:

- Infiltration
- Septic Systems
- Cross Connection
- Leaks and more...



BRIGHT DYES
Division of Kingsdale Chemicals

www.brightdyes.com
FAX: 937-886-9300

Booth 3053

NSF Certified to ANSI/NSF 11

LEAK DETECTIVE

FREE SAMPLE 1-800-394-0678

BIG SHOT

Underground Piercing Tools

Visit
www.footagetools.com
or call
1-888-737-3668

Footage TOOLS INC.

WHY SPEND HOURS ON GREASE CLOGS?

Cut your work time in half with the



PUSH JET

- Works on volume, not pressure
- Guaranteed not to kink
- Just \$79.00!

www.pushjet.com
918-606-1221

VISA MasterCard

SEWER CAMERAS DUCT & CHIMNEY CAMERAS HYDRO-JETTERS

Same Day & Overnight Shipping Available

1 Year Warranty



- Affordable Sewer, Chimney & Duct Cameras
- Lengths From 30' to 400'
- 16 Models to Choose From
- We Make it Simple

120' Color Camera
Complete System w/Color Monitor/VCR
\$2499

Prices Start at \$1349

800-688-0081
www.southcoastequipment.com

CHECK OUT THE LATEST PRODUCT NEWS

AT
CLEANER.COM/PRODUCT_NEWS

View all the past Product News online at cleaner.com/product_news

DYNAMIC CABLE REPAIR

We Repair:

- Gen-Eye I, II, III, Insight Vision, Electric Eel, GatorCams, Ratech, Vision Intruders, Inspection Cameras, Locators, Command Modules and Cables

48-Hr. Turn Around Time

INSPECTION CAMERAS ARE OUR ONLY BUSINESS!

973-478-0893

DYNAMIC REPAIRS
40 Arnot St., Unit 20 • Lodi, NJ 07644
www.dynamicrepairs.net

T&T TOOLS

800-521-6893
800-521-3260 FAX
E-mail sales@tandttools.com • www.tandttools.com

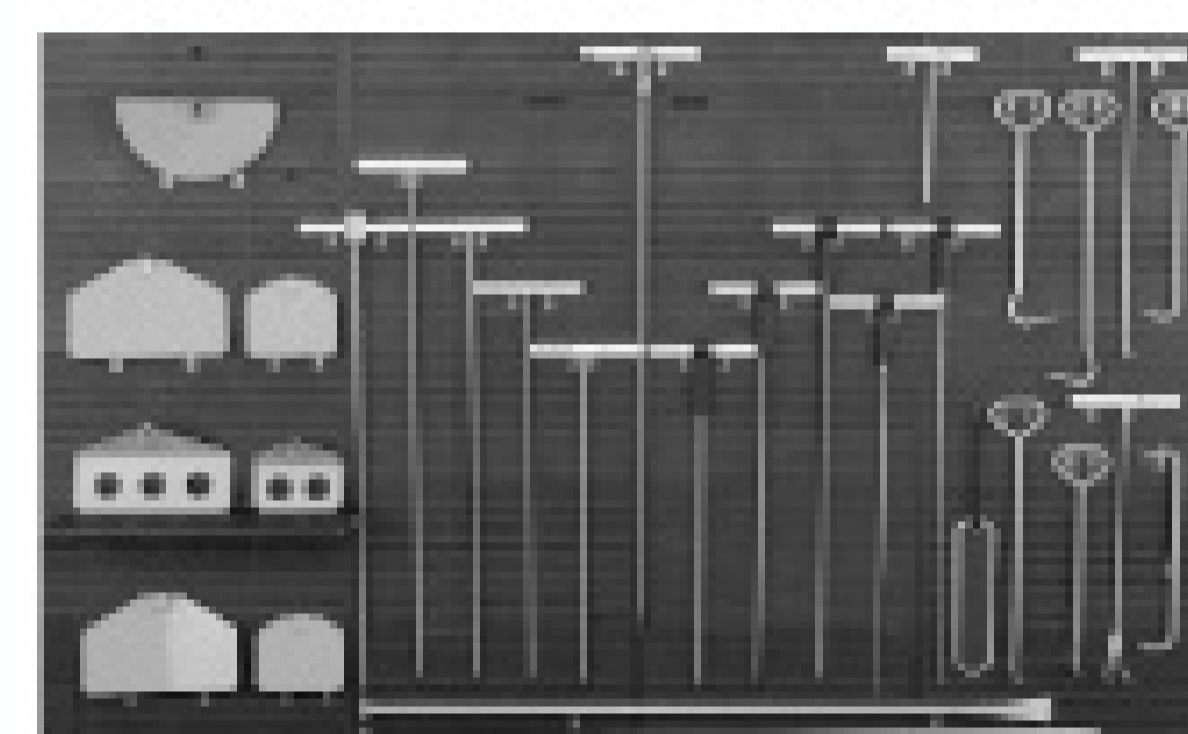

Mighty Probe™
Sludge Hoe™ (insulated)
Sludge Spud™
Manhole Hook
Tommy Hook™
Striking Head™

Handy Hook™
Water Probe
Curved Spud™
Top Popper™
Ground Buster™
Smart Stick™ (standard)

Booth 3099

www.tandttools.com

WWW.ROOTERMAN.COM



Booths 9015, 9115

Franchises available with low, flat fee New concept. Call 1-800-700-8062.

FRANCHISE PACKAGE \$7,950.

White Space Works

Call for details
800.994.7990

What you **learn** on these pages could be worth **\$1,000s.** It's all yours for **\$1 a month.***

Join 25,000 of your peers who welcome Cleaner every month. Each issue shows new tools and technology, ways to save on expenses, money-saving deals and much more.

To Subscribe Contact:
1.800.257.7222 or
www.cleaner.com

*\$15.50 for 1 year, \$25.00 for 2 years and \$35.00 for 3 years for US deliveries

Balanced Lift Eye



NEW!

American Jetter Mobile Cart Jetters

High Flow to 12 GPM
Pressure to 4000 PSI
Power to 30 HP
Easy Lift Eye

Free Shipping to U.S.

AmericanJetter.com
866 9HI-FLOW

CONFINED SPACE ENTRY PACKAGE

ONLY \$2,995

The best package on the market includes:

- 4-Gas Air Monitor (3 Year Sensor Warranty)
- 7' Tripod
- 3-Way Fall Protection
- Work Winch
- Full Body Harness



Booth 138

Add a Blower with 15' of duct for only \$300!
Add a 5 Minute Escape Respirator for only \$500.

Ask About Our

- Harben Jetters
- GapVax Combination Trucks
- Vac Replacement Parts
- Camera Systems
- Nozzles & Hoses
- Blowers & Ventilators
- Magnetic Lid Lifters
- Aluminum Folding Ladders
- Repairs & Service

MTECH 800.362.0240
www.mtechcompany.com

WATER JETS FOR RENT



- Units from 4,000 to 40,000 psi, including convertibles
- 60-600 hp, diesel or electric
- Rent, buy or lease
- Branches in MI, TX, NJ, CA, LA

NLB Corp. 1-877-NLB-7996
www.nlbcorp.com

I & I Solutions

INSTALL IN CLEANOUTS & MANHOLES



- Cleanouts 4" or larger
- For low flow areas
- Monitor new housing developments
- Battery operated
- An ultrasonic level measuring device

I & I SPY
VISIT OUR WEB SITE
www.twiispy.com

toll-free: **1.800.820.1321**
e-mail: **info@twiispy.com**



GET A GRIP WITH "CUA CLAWS"

A Simple Solution for Slippery PVC Pipe - **The Right Wheels**

CALL JERRY AT 714-697-8697
www.cua-claws.com

Jetter Hose

Parker/Dayco-Piranha-Aeroquip

- 1/8" - 3000, 4000, 4800 psi
- 1/4" - 4400, 5000 psi
- 3/8" - 4000, 5000 psi
- 1/2" - 3000, 4000, 5000 psi
- 5/8" - 4000 psi
- 3/4" - 2500, 3000 psi
- 1"-1-1/4" - 2500, 3000 psi

Call for Price & Delivery

Nozzles, Root Cutters, Clamps, Swivel Joints, Ball Valves, Hose Guides, etc.

Call for Catalog & Prices
800.365.6583

www.cloverleaftool.com

NEW IN TRENCHLESS TECHNOLOGY!



ACP Sag Correction System

- Remove low spots from PVC sewer lines using pneumatic powered vibration.
- No excavation required. Machine assembles in manhole.
- For Pipes 8 inch and larger.
- Can remove sags of any length.

— Advanced Construction Products —
Toll free 866.359.4670 | www.rerounders.com

PRESSURE WASHERS - INDUSTRIAL

XT Extreme Duty - Poly Drive

- 15,000 Hour Rated Belt
- Adjustable Throttle
- Low RPM Pump
- Twin Cylinder
- Electric Key Start
- Lifetime Frame Warranty



Up to **7000 PSI**

Part # 17H23	Part # 17H26	Part # 17H29
4.5GPM @ 6000PSI	4GPM @ 7000PSI	6GPM @ 7000PSI
24HP GX 670	24HP GX 670	40HP Kohler CH1000
\$4,799	\$5,249	\$7,599

Since 1981
1-800-786-9274

COMBAT GREASE

Choose Your Weapon (Liquid, Dry, Freeze-Dried)



Drain Line, Greasetrap, Septic System Maintenance

BIO¹

A COMPLETE ARSENAL FOR DRAINLINE REMEDIATION

Formulated Proudly in Partnership with **ONE BIOTECHNOLOGY**

1-800-951-4246
VISIT OUR BRAND NEW WEBSITE
WWW.ONEBIOTECHNOLOGY.COM

10K, 20K & 36K RENTAL FLEET

Flows to 120 GPM
Up to 500 HP



TRY BEFORE YOU BUY!
Waterblasters and engineered accessories.
Rental offices in TX, FL, CA & OH.
Everything to meet your cleaning needs!

GD GARDNER DENVER WATER JETTING SYSTEMS, INC.
CALL TOLL FREE
800-231-3628

The Amazing

ARCTIC BLASTER

Thawing Device

- > THAWS PIPES ABOVE & BELOW GROUND
- > USE ON PLASTIC, COPPER OR ABS
- > PERFECT FOR ROOF DRAINS

ARCTIC BLASTERS INC.
SUNDRE, ALBERTA

PH: **403.638.3934**
FAX: **403.638.3734**

JOIN THE DISCUSSION!



Cleaner Discussion Forum is an online based forum for industry professionals to swap information and ideas on topics related to the industrial, municipal & residential sewer & drain cleaning industry.

Sign up today at
www.cleaner.com



PUMPER & CLEANER ENVIRONMENTAL EXPO

February 24-27, 2010

KENTUCKY EXPOSITION CENTER



MAKE A SPLASH

Add Color to your Ad

Call
800.994.7990



Marketplace

advertising

Cleaner Marketplace gives you
nationwide exposure to thousands
 of industry professionals.

Layout and design is included **FREE**,
 and we can **fax or e-mail**
 you a proof for final approval!

Now Available In 4-Color or Spot Colors

*Choose a size that
 works best for you!*

Call **1.800.994.7990**

Size A: \$319^{00*}

1.875" W x 4.875" H

This size is great for two photos!

Size B: \$219^{00*}

1.875" W x 3.2" H

Perfect size for one photo!

Size C: \$119^{00*}

1.875" W x 1.5" H

A great value!

*Black and white prices, call for 4-color pricing.

**Send ad materials and payment to:
 COLE PUBLISHING INC. • P.O. BOX 220 • THREE LAKES, WI 54562**

Marketplace

Compact Crawler Camera System Provides Versatility

By Ken Wysocky

Obstacles in pipes that normally make it difficult to see defects farther down the line are now easier to examine with the P350 Flexitrac series of crawlers and camera inspection systems from Pearpoint.

The unit has 10x optical zoom capabilities. Three available interchangeable, high-resolution camera heads are available: straight view, pan-and-tilt, and pan-and-tilt with zoom. The cameras are designed with ultra-bright white LEDs for long, maintenance-free life. The P354 crawler operates in 4-inch pipe, and the P356 steerable crawler operates in pipes 6 inches and larger.

The P350 series is made to combine the simplicity and portability of a pushrod system with the performance of more expensive crawler systems, says Tom Schmandt, vice president of inspection products for Radiodetection.

"The straight-viewing camera and P354 crawler are compact enough to fit inside a 4-inch

pipe," Schmandt says. "Plus, the controller also works with our P330 pushrod system, so you can employ either a tractor-based system or a pushrod system, all operable with just one controller. There's no need for a second control unit."

The series also includes digital recording for high image quality. The cameras transmit images to an 8-inch, industrial grade TFT screen. Operators can zoom and rotate photos and edit live and recorded video in real time.

The control module, which along with the drum has a weatherproof rating of IP53, records survey data on a 2-gigabyte flashcard. Using a card reader that plugs into the USB port of a PC or laptop computer, the operator can download videos and data with special Windows-based software, and edit the videos and convert data reports to Microsoft Word documents.

"You can burn the video onto a DVD or e-mail it to a customer's compatible cell phone," Schmandt says. The crawlers are made of brass



and stainless steel, can operate fully immersed and are water-resistant and rated IP68 up to 100 meters. The unit comes with either a manual drum or motorized drum that can handle up to 825 feet of cable.

For information: www.radiodetection.com; 800/688-8094.



Electric Eel Offers Pipe-Thawing Machines

The UES 190D and 200D pipe-thawing machines

from Electric Eel Manufacturing Co. Inc. are designed to thaw frozen copper or steel pipe up to 75 feet in length, depending on pipe O.D. The units use low-voltage, high-amperage power and come with 115-volt power pack, two 25-foot cables with pipe clamps and circuit breaker to protect against overloads. 800/833-1212; www.electriceel.com.

RIDGID Introduces microExplorer Inspection Camera

The handheld microExplorer digital inspection camera from RIDGID enables users to take digital quality JPEG images and record video onto a secure card inserted into the integrated SD slot in the unit. An integrated mini USB port also is available to transfer data onto a computer where it can be saved, e-mailed or posted online. The camera features 3X zoom and/or pan functions and 3.5-inch LCD screen. 800/769-7743; www.ridgid.com.



Cam Spray Introduces VM Series Drain Jeters

The model VM4007H drain jetter from Cam Spray produces 4,000 psi at 7 gpm, while model VM3508H produces 3,500 psi at 8 gpm. Standard features on both include a 24-hp Honda engine, triplex ceramic plunger pump, power pulse, 500 feet of 3/8-inch hose on a DC-powered reel, four-nozzle kit and 125-gallon water tank. 800/648-5011; www.camspray.com.

Reelcraft Offers Side-Mount Cart Handle

The side-mounted handle option on Reelcraft hose reel carts enables the cart to easily attach to mobile equipment for transport to multiple locations. The square, tubular-steel frame resists deformation. Corrosion-resistant, baked-on powder coat finish guards against the elements. Designed to be used with Reelcraft's 6- and 12-inch Series 30,000 reels, the cart also features a zinc-plated 1/2-inch steel axle and 8-inch semi-pneumatic tires. 800/444-3134; www.reelcraft.com.





Guzzler Introduces Predator Vacuum Tanker

The Predator liquid vacuum tanker from Guzzler Manufacturing is designed for

handling bulk liquids, sludge and semi-solid waste. The tanker features 3,000-gallon payload capacity, standard vacuum pump capable of 27 to 29 inches Hg and maximum airflow of more than 400 cfm (300 cfm at 18 inches Hg). Alternate pump sizes are available. The unit's single compartment, carbon steel tank is rated for continuous maximum vacuum operation and 15-psi working pressure. Built in accordance with Section VIII of the American Society of Mechanical Engineers boiler code, the tank also complies with the U.S. Department of Transportation specification DOT412 for hauling hazardous materials on the highway. 800/627-3171; www.guzzler.com.

General Pipe Updates Mini-Rooter XP

The updated Mini-Rooter XP cable machine from General Pipe Cleaners features an upright frame with roll bars to protect the motor while traveling up stairs or loading the unit into a truck. The drain cleaner can feed or retrieve cable at up to 16 feet per minute and adjust to 1/2- or 3/8-inch cable without additional tools. The powder-coated drum can hold up to 75 feet of 1/2-inch cable and has an inner drum cage to prevent cable tangling. 800/245-6200; www.generalpipecleaners.com.



Reline America Introduces Mobile Curing Truck

The mobile curing truck from Reline America is designed

for use with the Blue-Tek cured-in-place-pipe system. Built on a small truck chassis, the system is equipped with a 500-foot cable reel (upgradeable to 1,000 feet) and a portable control unit that features an integrated touch-screen panel and Quality-Tracker system that documents every foot of the curing process on a tamper-proof computer file. 866/998-0808; www.relineamerica.com.

NLB Introduces Roto-Reel Units

Roto-Reel hose reels from NLB Corp. are designed to automatically feed high-pressure waterjet hose for industrial pipe and sewer cleaning. The reels also rotate the hose as it feeds, enabling it to get through tight bends and maximize cleaning coverage. The model Roto-Reel 200 has a hose capacity of 200 feet and is intended for applications requiring water pressure of up to 20,000 psi. The Roto-Reel 500 model has a hose capacity of 500 feet and is made for applications up to 10,000 psi. Both models feed hose at up to 40 feet per minute and rotate the hose reel at 30 rpm. Available with air or hydraulic power, the reels come skid- or trailer-mounted and feature a protective cap. 248/624-5555; www.nlbcorp.com.



Coxreels Designs Hand-Crank Power Cord Reel

The 1125 PCL Series professional grade hand-crank power cord reel from Coxreels features an all-welded "A" frame. Models are designed to handle up to 250 feet of 12/3 gauge and 200 feet of 10/2 gauge SO type power cord. Other features include an integrated cable keeper to prevent the 5-foot pigtail from whipping or twisting and either a hand crank or electric motor rewind. 800/269-7335; www.coxreels.com.

Vivax Introduces vLoc Pro Line Locator

The vLoc Pro digital line locator from Vivax Corp. is a multi-frequency locator with three antennae configuration modes. The unit is designed to locate the target line and display the depth and current measurements instantaneously on its bright color display. The receiver is powered by rechargeable and alkaline batteries. When the rechargeable batteries drop below a certain voltage, the alkaline batteries take over. The unit weighs four pounds and is both Bluetooth- and GPS-compatible. 866/332-1688; www.vivax.biz.



Thompson Offers 4-inch Dry-Prime Pump

The modular 4-inch, dry-prime pump from Thompson Pump and Manufacturing Co. Inc. features a high-efficiency impeller design and delivers flows up to 1,450 gpm, heads up to 150 feet and solids up to 3 inches. The unit utilizes a fuel-saving, three-cylinder diesel engine and offers three priming systems, including compression/venture, vacuum pump and diaphragm primer. 800/767-7310; www.thompsonpump.com.

Hannay 6000 Series Designed for Longer Hose Lengths

Hannay's 6000 series reels are designed for a variety of power rewind options, while their heavy-duty construction allows for efficient handling of longer lengths of hose. Reels operate at pressures to 1,000 psi and can manage temperatures from -80 degrees F to 185 degrees F. Features include either a manual gear-driven crank rewind or chain and sprocket driver powered by an electric, hydraulic or compressed air motor. The standard inlet is a 90-degree ball-bearing swivel joint and 1-inch female NPT threads with 1-inch female NPT standard outlet. Crank rewind reels have a pinion brake, while power reels have a comet brake. 877/467-3357; www.hannay.com.



StoneAge Offers Barracuda Cartridge Upgrade

The 40,000-psi Barracuda cartridge upgrade from StoneAge Inc. is designed to increase the operational life of the high-pressure seals. The upgraded cartridge assembly will retrofit into existing 40,000-psi Barracuda, Gopher and SL tools. 866/795-1586; www.stoneagetools.com. ■



High Quality SEWER CLEANING EQUIPMENT

Your JETTER comes to LIFE with our UNRIVALED EQUIPMENT!

USB-SEWER EQUIPMENT CORPORATION proudly DEVELOPS and DISTRIBUTES innovative, unrivaled sewer cleaning equipment, precision manufactured in Germany and The Principality of Liechtenstein to the highest technical standards. These products are leaders in the industry and include **NOZZLES, TURBO CHAIN CUTTERS, MILLING CUTTERS, SPECIALTY TOOLS** and **ACCESSORIES** for the municipal and industrial markets.



TURBO CHAIN CUTTERS



MILLING CUTTERS



SPECIALTY TOOLS



Visit Us in Louisville!



FOR A DISTRIBUTOR NEAR YOU, PLEASE CONTACT:

USB-Sewer Equipment Corporation



Booth 52

1700 Enterprise Way • Suite 116 • Marietta, GA 30067 • PHONE 770-984-8880 • FAX 770-984-2802
EMAIL info@usbsec.com • WEB www.usbsec.com



HIGHEST QUALITY. LOWEST COST.

- Rugged, ultra-compact and lightweight
- Simple one-button operation
- Stainless steel alligator clip
- Continuous LCD shows simultaneous gas concentrations for H₂S, CO, O₂, and combustibles
- Internal vibrating alarm for high noise areas
- Backlight
- Four alarm levels
- Simple automatic calibration procedure
- Fully compatible with BW's MicroDock II automatic test and calibration system

CALL TOLL-FREE
1.800.325.3730

MRP

Milwaukee Rubber Products, Inc.
P.O. Box 451 • Butler, WI 53007
N52 W13319 Falls Creek Ct.
Menomonee Falls, WI 53051



www.milwaukeeerubber.com

Extend Your Hand February 25-28



15,000
NETWORKING OPPORTUNITIES EXIST
www.pumpershow.com • **800.257.7222**

ENVIROSPEC

**ALLISON IRON HORSE
PRESSURE WASHER/JETTER
38 HP DUAL PUMPER**

**Up to 24 GPM
Up to 4,500 PSI**

see our complete
ON-LINE CATALOG
www.envirospec.com

'Quick Change'
Lubrication

26 Gallon
Fuel Tank

YU-2140
Unloaders

1 Gun
or
2 Gun
Operation

General
Pumps

38 or 40
Horsepower
KOHLER

KOHLER
DIESELS
Available

'Power in the Hands of a Few'

**...the best place in the industry for
PARTS & PRICE - GUARANTEED!**



For Example:
Pressure Hose
3,000 PSI - 50'
\$29.95

For Example:
GENERAL PUMP
TS-2021
\$399.00

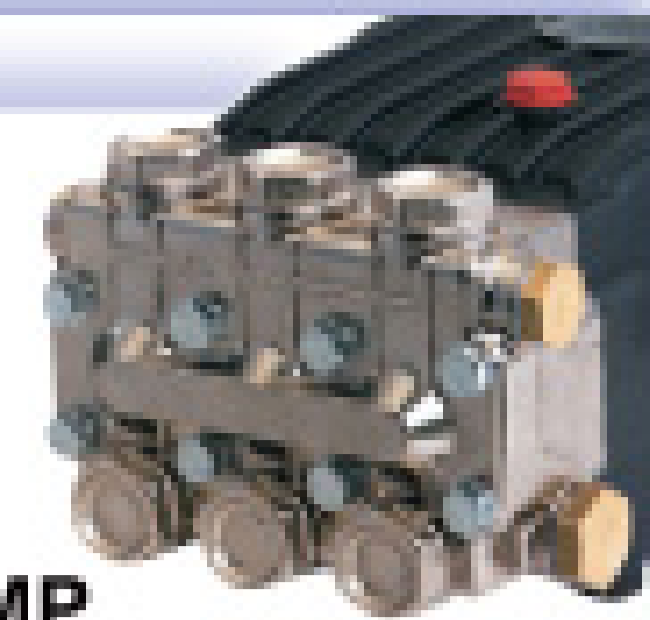

**3,500 PSI
5.6 GPM**

**NITRO
30 HP
12 GPM**

**TWO GUN
SYSTEM**

**KOHLER
ENGINES**

Transmission
Drive System

The Best
Money Can Buy...

← \$6995.00
\$4995.00 →

Call for a Catalog
1-800-346-4876



For the best selection of used City Equipment khtrucks.com



2001 Volvo Tandem Axel Vac-Con: V309SHA; Rear Engine: John Deere; 3 Stage Fan Unit; Bean pump: 80 GPM @ 2000 PSI; 600' 1" New Jetting Hose



2002 Vector 2115; Roots 15" Blower; Vector Jetting Pump 80 GPM @ 2000 PSI; 15 Yard Debris Tank with Body Flush Out, and Pump Off Systems!



2000 International 2554; VAC-CON: V312LHA; S/M 08992206; 3 Stage Fan Unit; 12 Yard Debris Tank; John Deere Rear Engine; Bean 80 GPM Pump



2000-2003 (4) To choose from Pipe Hunter Jetters. Also specializing in all makes of Truck and Trailer mounted Jetters!



1994-2003 Combination Sewer Machines All Makes and Models!!! PD, and Fan Machines, Single and Tandem Axel, 9 to 15 Yard Debris tanks.



LIKE NEW!! 1998 Vector; 2110 Miles: 28,213; Rear Engine: Cummins Diesel; Vector Pump 80 GPM @ 2500 PSI; 1" Hose; 2 Stage fan; 4 New Extension Tubes

KEN'S TRUCK & EQUIPMENT | 5907 N. I-35E | WAXAHACHIE, TX 75167 | (972) 938-1905 | khtrucks.com

nesco
Sales & Rentals

1-800-252-0043



MudDog
Hydroexcavator

2008 Sterling L9000, CAT C13, manual, full opening tailgate, vacuum pump 6000 CFM, Triplex water pump 14 GPM and 3000 PSI, 335° boom rotation.

www.nescosales.com

NESCO LLC • 3112 E STATE RD 124 BLUFFTON



All In!

When you receive *Cleaner* each month there is no need to bluff.

Join 25,000 of your industry peers each month who welcome *Cleaner*, for the unlimited value it brings them. Each issue will show you new tools, tips to save on expenses, money-saving deals and much more.

800.257.7222
www.cleaner.com

Subscribe today
to guarantee
your winning
hand!

Central Winnelson

SeeSnakes™

Call us for Our
Lowest Price!



LCD - DVD
MONITOR
AVAILABLE

SeeSnakes and
Locators Ship Free!

AUTHORIZED
RIDGID SEESNAKE
REPAIR CENTER

Ridgid SeekTech®

Locating Made *Easy*

**Price Too Low
to Advertise!**

6% one year financing available.
Longer lease rates also available.
Call Keith for details.

Buying a SeeSnake?

**CALL US FOR
GREAT PRICING
AND FREE SHIPPING!**

**WE WILL
NOT BE
UNDERSOLD**

- Call Us Evenings and Weekends -
Keith: 405-602-9155 & Jim: 405-205-3974

5037 NW 10th • Oklahoma City, OK 73127
www.centralwinnelson.com

Toll Free: 888.947.8761



Your **Single Source** Water Jetting Solution

NEW!
Remote
Control
Valves

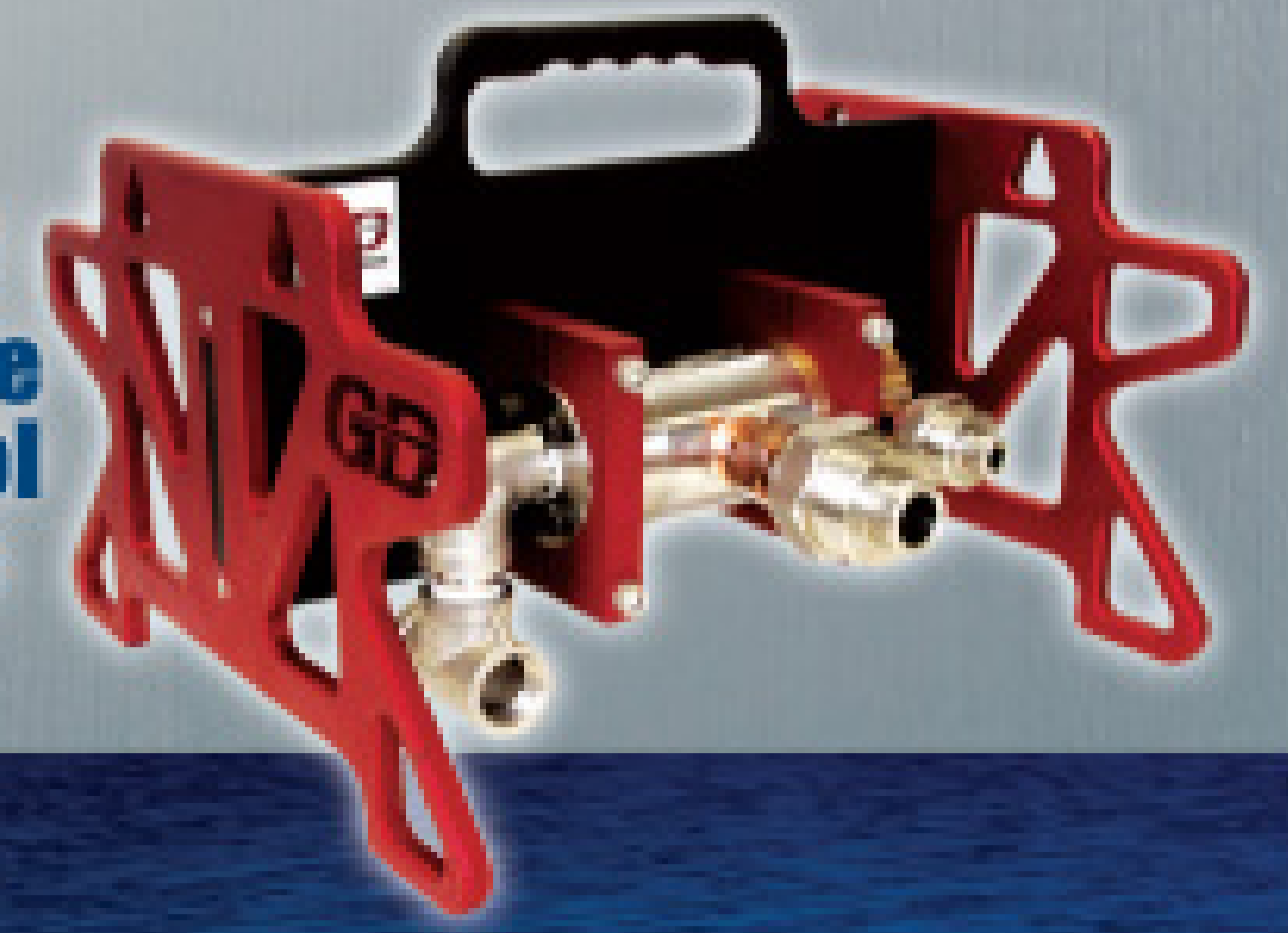

Premiering the NEW MULTI-BLASTER™ 10/20/40/50k Pump Line

**Instant
Convertibility**

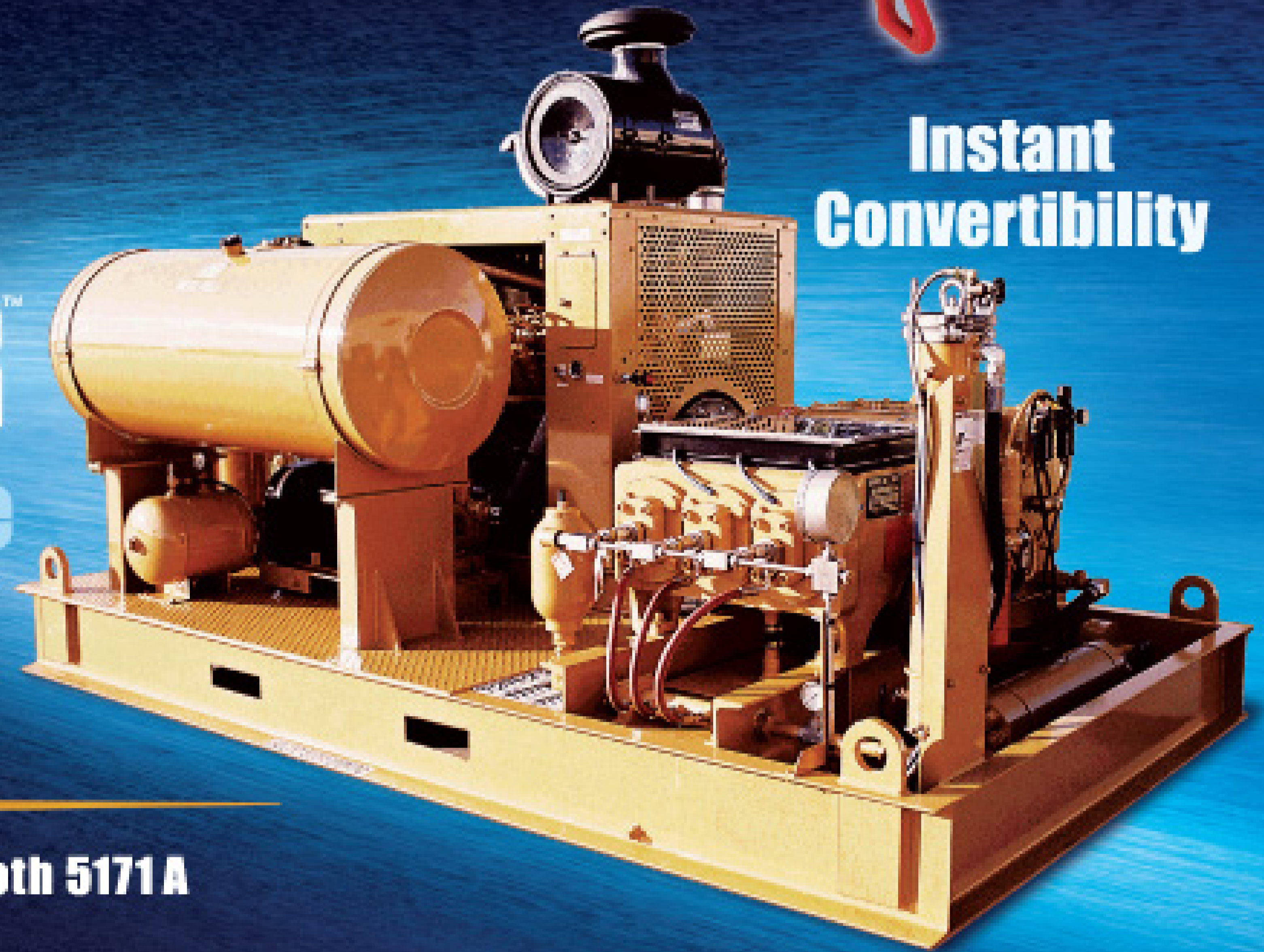

Your Future.....NOW! See us at Booth 5171A

1 (800) 231-3628 | www.waterjetting.com

Petersen® Pipe Plugging Systems



Economical Hot Tap Plugging Systems

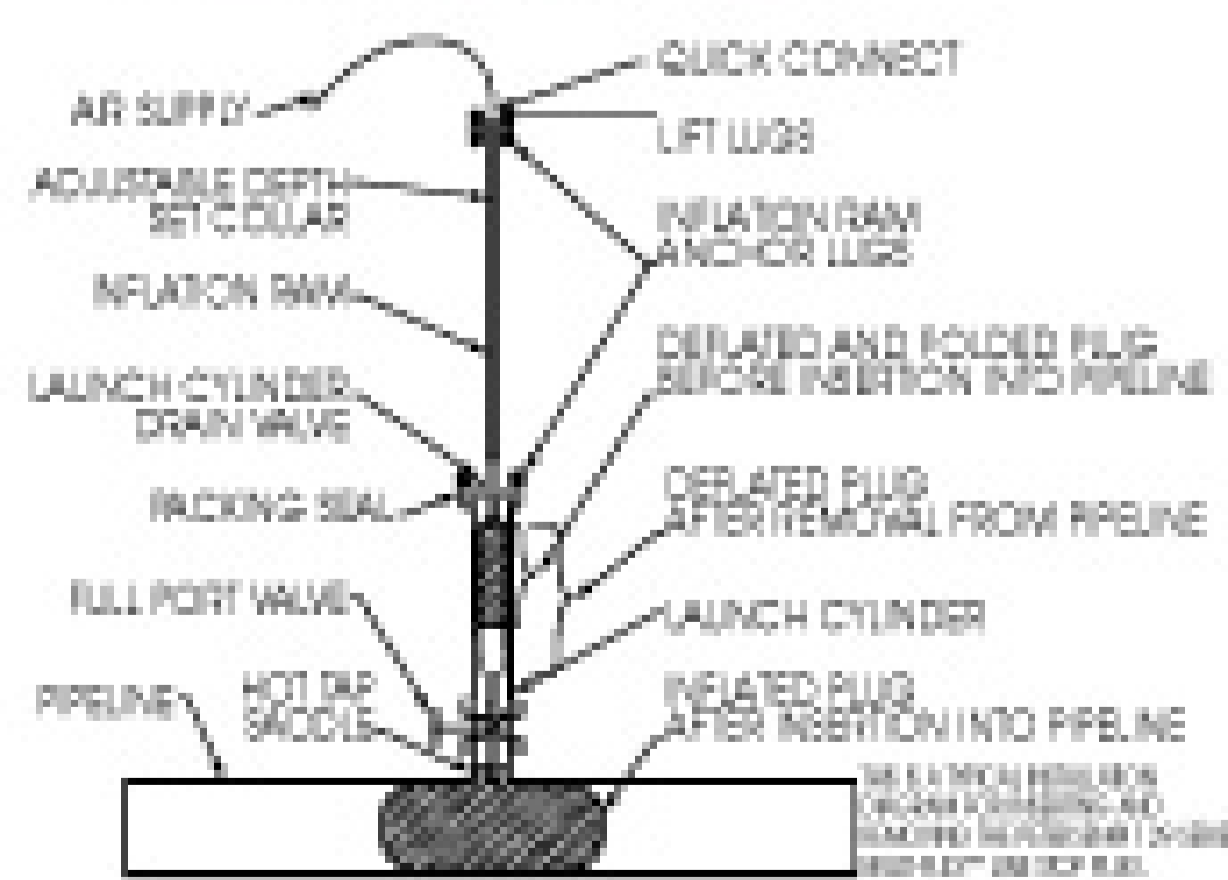

Pipe Plugs and Packers for all your Pressure, Chemical, and Temperature Requirements. Call us to quickly customize a pipe plug or plugging system for your specific application.

www.pipeplug.com

Petersen PRODUCTS COMPANY
Serving Professionals Since 1916

PHONE 800.926.1926 OR 262.692.2416
FAX 800.669.1434 OR 262.692.2418

Master-Lateral Pipeline Renewal System

"Masterliner can transform a problem pipe into a new, strong, leak-proof system in a matter of hours"

Benefits:

- Masterliner's signature PDQ resin cures without external heat source
- On site training available
- Little to No excavation
- Fast and Easy to install
- Bulk material available
- Perform as many as 7 repairs in a day
- Exceeds ASTM specifications
- Quality assurance
- Long term solutions
- Improves flow characteristics
- Virtually eliminates infiltration & exfiltration
- Full range of pipe sizes
- Custom pipe diameters and wall thickness
- FACTORY DIRECT PRICING!!!

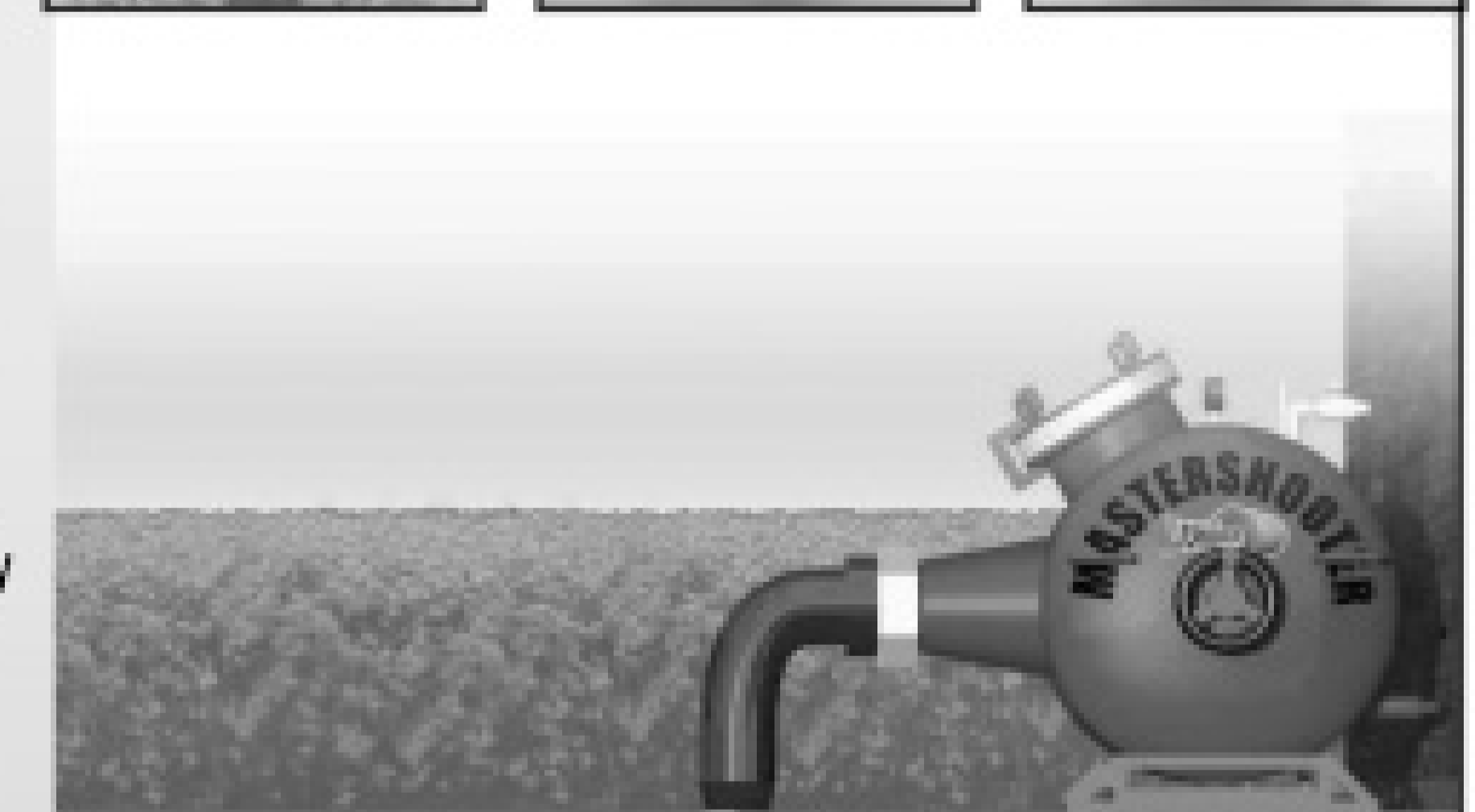
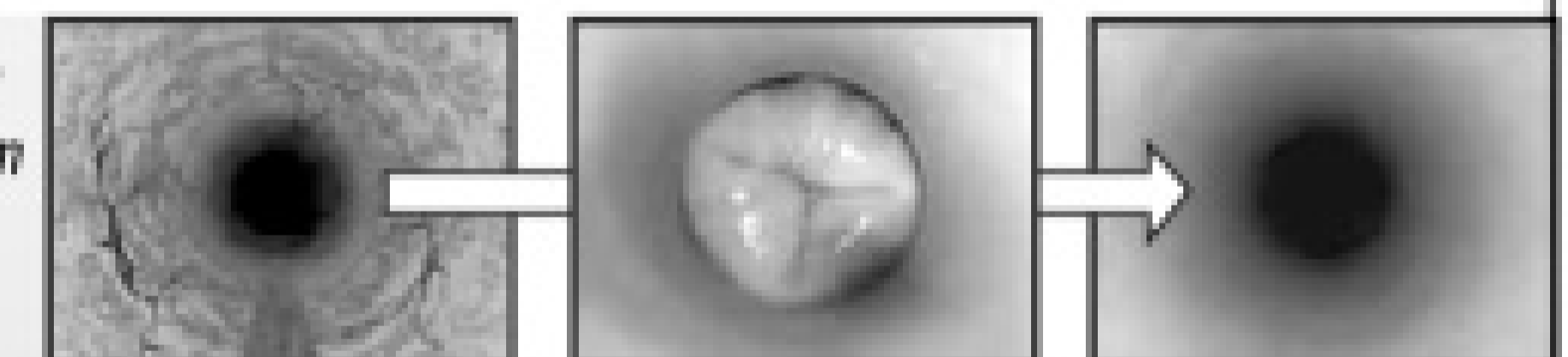

* Masterliner's physicals exceed all applicable ASTM standards including ASTM F-1216



1-888-DIG-FREE (888-344-3733)

Masterliner Incorporated • 42305 South Airport Road • Hammond, LA 70403
www.masterliner.com • liner@masterliner.com PH 985-386-3006 FX 985-386-0250

pon of s Detection

Technicians take pride in being a resource for a wide range of residential and commercial services.

...and more of the...
...and more of the...
...and more of the...

...and more of the...
...and more of the...
...and more of the...

Business

...and more of the...
...and more of the...
...and more of the...

...and more of the...
...and more of the...
...and more of the...

By the Float

Large-diameter pipes, built on portable platforms, arrive for performing top-quality video inspections.

...and more of the...
...and more of the...
...and more of the...



An inspection camera lens is lowered into a large pipe to inspect sewer. Photograph by Bill Anderson.

...and more of the...
...and more of the...
...and more of the...

...and more of the...
...and more of the...
...and more of the...



...and more of the...
...and more of the...
...and more of the...

...and more of the...
...and more of the...
...and more of the...

...and more of the...
...and more of the...
...and more of the...

High

...and more of the...
...and more of the...
...and more of the...

...and more of the...
...and more of the...
...and more of the...

...and more of the...
...and more of the...
...and more of the...



...and more of the...
...and more of the...
...and more of the...

...and more of the...
...and more of the...
...and more of the...



...and more of the...
...and more of the...
...and more of the...

...and more of the...
...and more of the...
...and more of the...

...and more of the...
...and more of the...
...and more of the...

Sleuth

...and more of the...
...and more of the...
...and more of the...

...and more of the...
...and more of the...
...and more of the...

...and more of the...
...and more of the...
...and more of the...



...and more of the...
...and more of the...
...and more of the...

...and more of the...
...and more of the...
...and more of the...



...and more of the...
...and more of the...
...and more of the...

...and more of the...
...and more of the...
...and more of the...

...and more of the...
...and more of the...
...and more of the...

Plumbing

...and more of the...
...and more of the...
...and more of the...

...and more of the...
...and more of the...
...and more of the...

...and more of the...
...and more of the...
...and more of the...



...and more of the...
...and more of the...
...and more of the...

...and more of the...
...and more of the...
...and more of the...



...and more of the...
...and more of the...
...and more of the...

...and more of the...
...and more of the...
...and more of the...

...and more of the...
...and more of the...
...and more of the...

Technology

...and more of the...
...and more of the...
...and more of the...

...and more of the...
...and more of the...
...and more of the...

...and more of the...
...and more of the...
...and more of the...

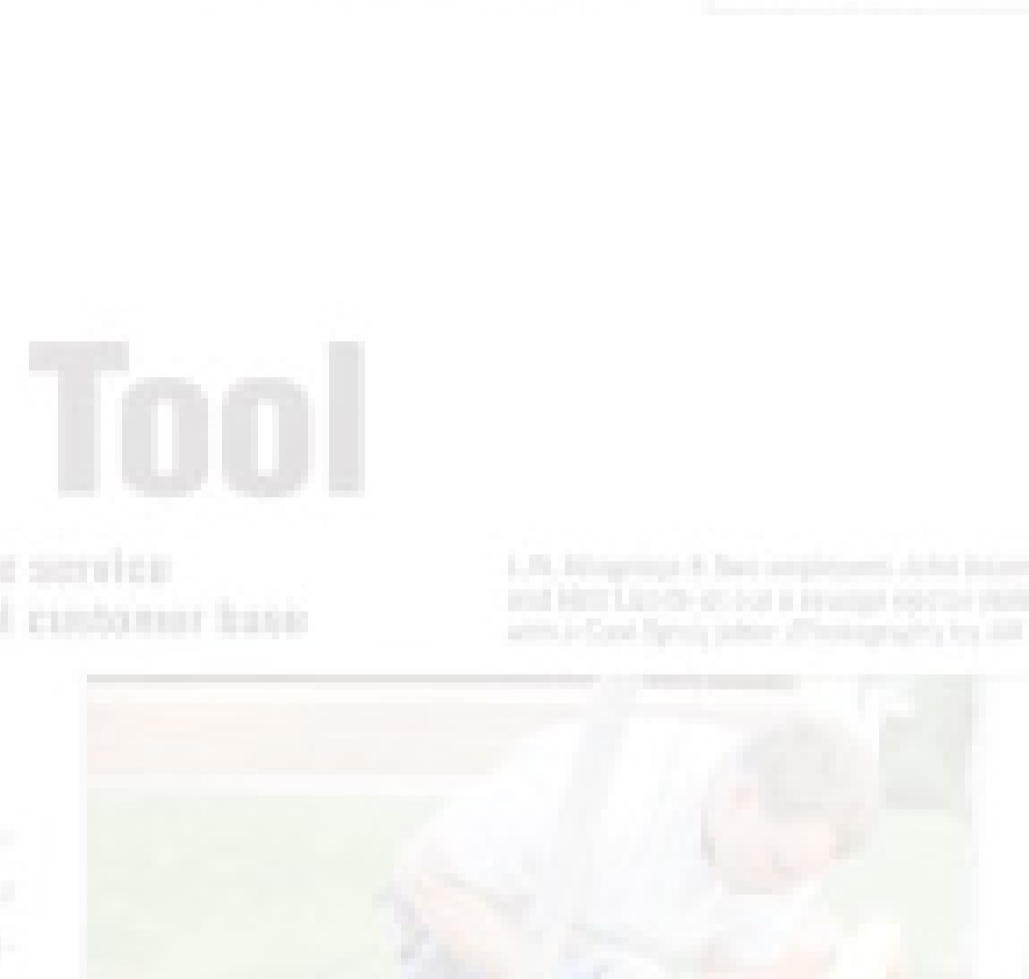

...and more of the...
...and more of the...
...and more of the...

...and more of the...
...and more of the...
...and more of the...



...and more of the...
...and more of the...
...and more of the...

...and more of the...
...and more of the...
...and more of the...

...and more of the...
...and more of the...
...and more of the...



Featured in an article?

Make the most of it!

REPRINTS AVAILABLE

- We offer:
- Full copies of the original magazine
- Hard copy color reprints
- Electronic reprints

Visit cleaner.com/editorial for articles and pricing

E-mail jeffl@colepublishing.com or call 800-257-7222

The Perfect Tool

...and more of the...
...and more of the...
...and more of the...

...and more of the...
...and more of the...
...and more of the...

...and more of the...
...and more of the...
...and more of the...

...and more of the...
...and more of the...
...and more of the...

...and more of the...
...and more of the...
...and more of the...

...and more of the...
...and more of the...
...and more of the...

...and more of the...
...and more of the...
...and more of the...

...and more of the...
...and more of the...
...and more of the...

Line by Line and 4x4

...and more of the...
...and more of the...
...and more of the...

...and more of the...
...and more of the...
...and more of the...

...and more of the...
...and more of the...
...and more of the...

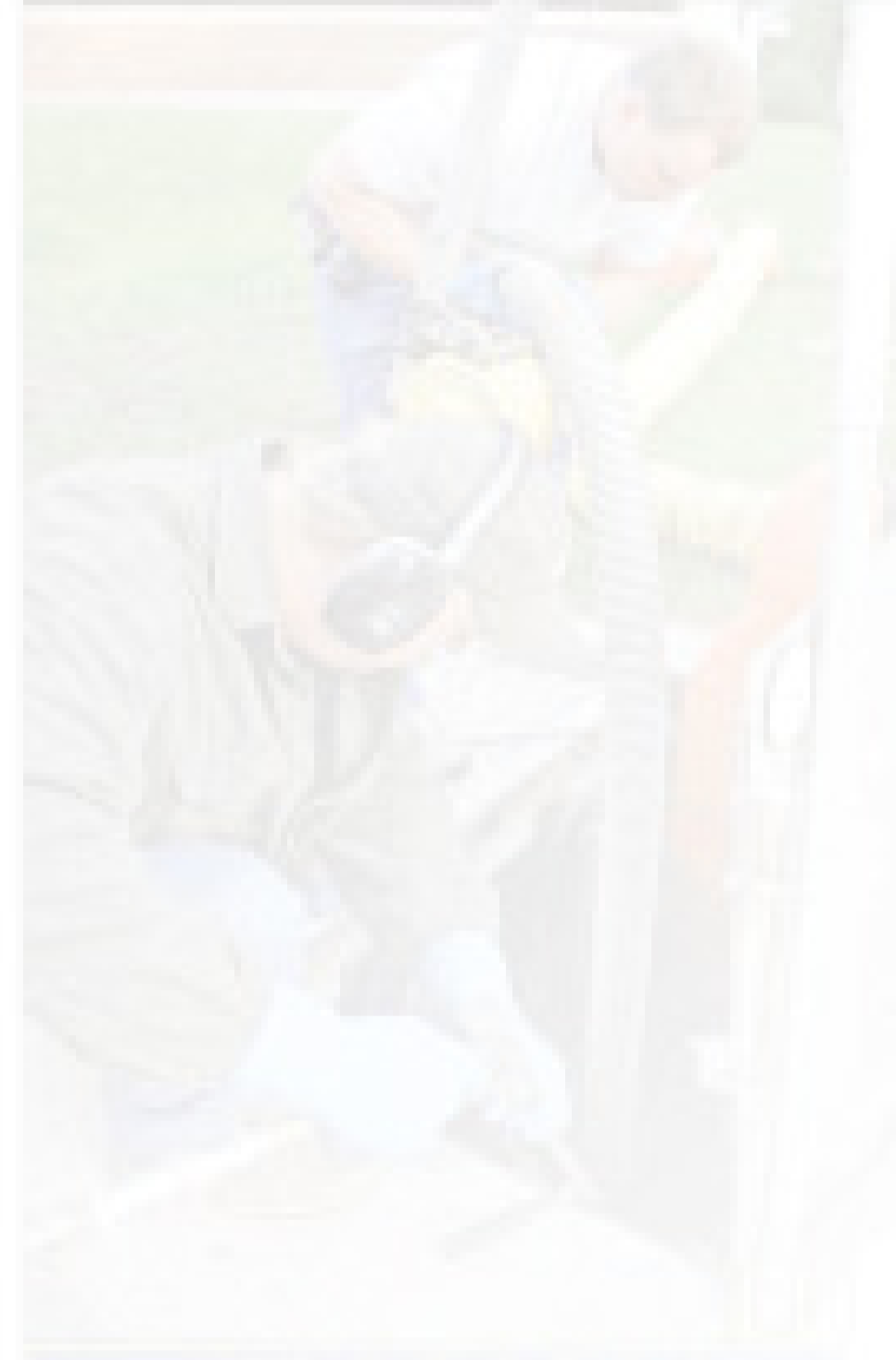

...and more of the...
...and more of the...
...and more of the...

...and more of the...
...and more of the...
...and more of the...

...and more of the...
...and more of the...
...and more of the...

...and more of the...
...and more of the...
...and more of the...

...and more of the...
...and more of the...
...and more of the...

...and more of the...
...and more of the...
...and more of the...

...and more of the...
...and more of the...
...and more of the...

...and more of the...
...and more of the...
...and more of the...

...and more of the...
...and more of the...
...and more of the...

...and more of the...
...and more of the...
...and more of the...



"water as a tool"

WOMA
CORPORATION

WOMA High Pressure Systems

help solve almost any Industrial cleaning, maintenance and decontamination problem.

- HIGH PRESSURE PUMPS TO 40,000 PSI
- 25-600 HP HIGH PRESSURE UNITS
- ACCESSORIES TO MEET ANY APPLICATION

Let us help you more effectively use "water as a tool."

When quality, performance and reliability matter...
PHONE: 800-258-5530 . FAX: 732-417-0015

Everyone talks about creating
a greener environment.

You actually do it.

Find the tools you need to keep your communities green at
www.colepublishing.com.

Publishing environmental trade magazines since 1979.

ASHER
CELEBRATING 41 YEARS

VAC-CON Lease -Finance Plans

Take Advantage of Sec. 179 Depreciation

Delivery Throughout The USA
Los Angeles, CA

800.896.2480



Stock No. 14729
45,000 Original Miles

Sewer Cleaner Combos
& Hydroexcavators
(2) 2000 Sterling Diesel
VAC-CON Combo Units
\$65,000 each

sales@alasher.com

www.alasher.com

GET A GRIP ON LOCATING

WITH PROTOTEK'S NEW LF2200 The workhorse of receivers.



- BRIGHT ADJUSTABLE SCREEN—EASY TO READ, EASY TO POSITION
- STRONGER UNI-BODY HANDLE
- 3 SOURCES OF FEEDBACK: SCREEN, VIBRATING HANDLE AND SPEAKER
- WORKS WITH JUST ABOUT ANY FREQUENCY
- MORE SENSITIVE—WORKS DEEPER
- MODULAR DESIGN FOR EASY UPDATES
- AUTOMATIC DEPTH READOUT—DEEPER THAN EVER BEFORE

EXPO SPECIAL
10% OFF KITS

Visit us at Expo and meet Scott or Kent. You've got questions. We've got answers.

You gotta see this!
Stop by booth 3187
in Louisville for
a demo!



Prototek

800-541-9123

Web: www.prototek.net

Email: prototeksales@prototek.net



MyTana Moments

MyTana Seeks Unusual Moments

MyTana Manufacturing Co. Inc. is seeking interesting, unusual or amazing moments captured with a MyTana or other camera system. The moments will be posted on the company's Web site and YouTube. Viewers will be able to vote for the

most interesting moment. The winner will receive a MyTana accessories package. To enter or vote, go to www.mytana.com.



EelCam Offers Pipeline Inspection Brochure

The EelCam Pipeline Inspection Systems brochure from Electric Eel Manufacturing Co. Inc. features a range of inspection systems, from the black-and-white EelCam Micro to the full-color EC-10LCD with self-leveling camera.

Vanair Moves to 60,000-square-foot Manufacturing Plant

Vanair Manufacturing Inc. has moved to its new 60,000-square-foot vehicle-mounted air compressor and generator manufacturing plant in Michigan City, Ind.



Federal Signal Launches Online Store

The online store from Federal Signal Environmental Solutions Group, www.fssolutionsgroup.com, features fast search capabilities to locate and buy thousands of parts and accessories for the Guzzler brand, as well as the Vactor HXX and other vacuum excavators.



Envirosight Names Adams Operations Manager

Jim Adams has joined Envirosight LLC as operations and service manager. He will assist the company's sales partners in becoming authorized Envirosight service centers. ■

Perma-Liner Names Business Development Managers

Cole Perkins has been named southeast business development manager and Rich Cristi has been named northeast business development manager for Perma-Liner Industries Inc. Perkins has a degree in industrial distribution and logistics from East Carolina University and three years of sales experience.

LMK Launches New Web Site

LMK Enterprises Inc. has launched its new Web site, www.performanceliner.com. The site offers online product brochures, installation specifications, access to ASTM standards, lining material specifications, technologies for renewing lateral pipes and more.

StoneAge Releases 2009 Product Catalog

The 2009 product catalog from StoneAge Inc. features nine new products for all waterblasting applications, including tanks and vessels, pipes, tubes, sewer cleaning and surface preparation.

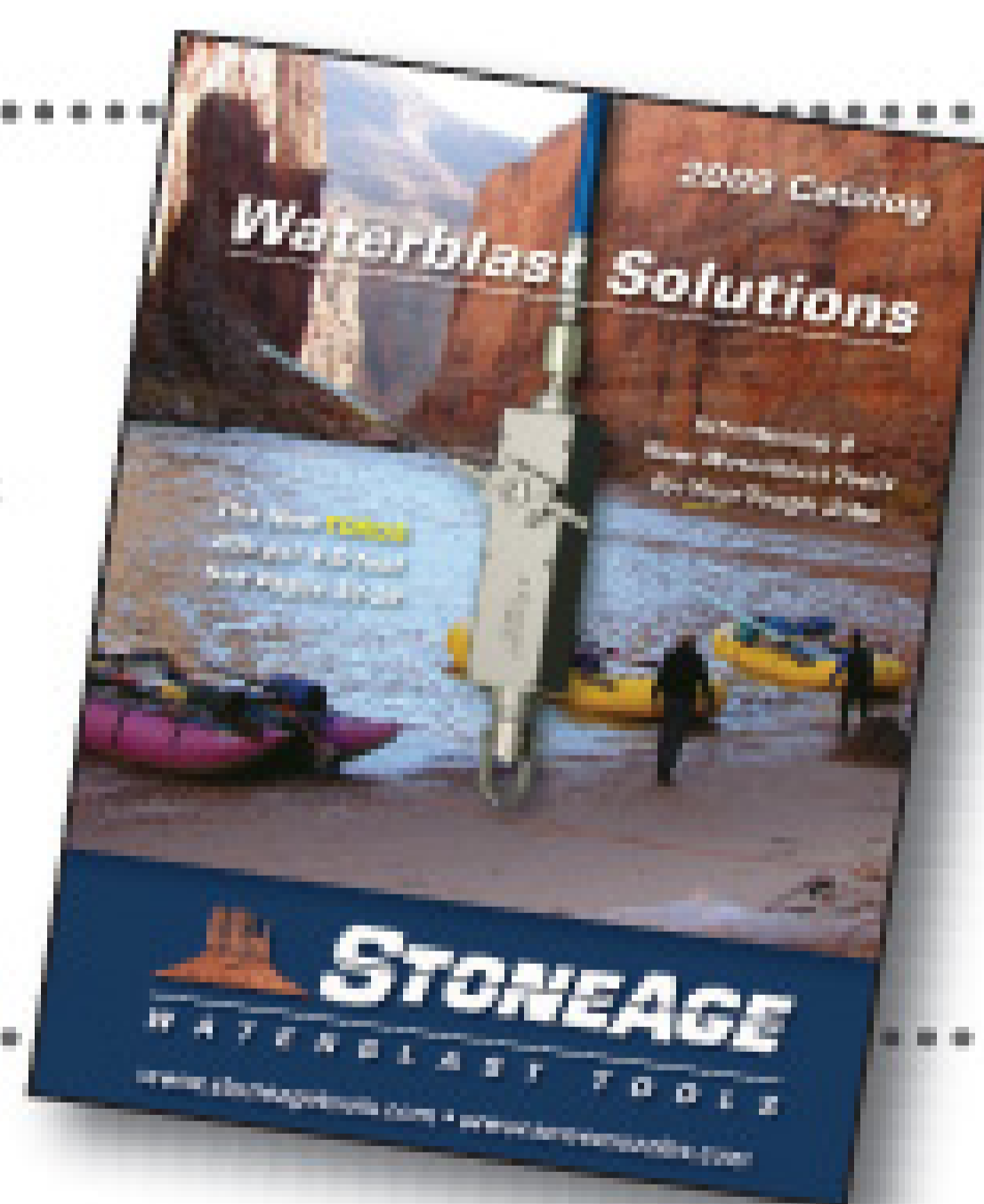

Super Products CEO Retires, Successor Named

Mike Vanden Heuvel has been named president and chief executive officer for Super Products LLC. He had served as vice president of industrial sales. Vanden Heuvel replaces Jim Wurster who retired at the end of the year. Wurster joined Super Products in 1976 as a project engineer and was named president and CEO in 1984.



PITTSBURGH WIRE & CABLE INC.
POWER • VIDEO INSPECTION • FIBER

Proud Supplier of

Multiconductor VIDEO INSPECTION CABLE

Manufactured and Distributed in the U.S.A.

**CABLE STOCKED
CUT TO YOUR REQUIRED LENGTH**

Call for samples and more information on this and other high quality video inspection cables!

1-800-458-1222

210 Bilmar Dr.
Pittsburgh, Pennsylvania 15205
Phone: 800-458-1222 • 412-920-7190 • Fax: 412-920-7197
www.pittsburghwire.com





FREE Information from Advertisers

MARCH 2009

FAX Completed page to **715-546-3786** to receive **FREE** information

FREE Info.	ADVERTISER	PAGE
<input type="checkbox"/>	A Corp/Rooterman	34
<input type="checkbox"/>	Advanced Infrastructure	68
<input type="checkbox"/>	Al Asher & Sons, Inc.	111
<input type="checkbox"/>	Allan J. Coleman Co.	31, 87
<input type="checkbox"/>	AMerik Engineering	84
<input type="checkbox"/>	Aqua Mole Technologies	22
<input type="checkbox"/>	Aries Industries, Inc.	35
<input type="checkbox"/>	Arthur Products	72
<input type="checkbox"/>	Avanti International	91
<input type="checkbox"/>	Bowman Tool Co. & Systems	36
<input type="checkbox"/>	Bright Dyes/Div. of Kingscote	68
<input type="checkbox"/>	Cable Center, The	14, 89
<input type="checkbox"/>	Cam Spray	32
<input type="checkbox"/>	Canplas Industries Ltd.	18
<input type="checkbox"/>	Cape Cod Biochemical Co.	22
<input type="checkbox"/>	Central Oklahoma Winnelson	108
<input type="checkbox"/>	Chempure Products Corp.	66
<input type="checkbox"/>	Cloverleaf Tool Co.	4, 18
<input type="checkbox"/>	Cobra Technologies	30
<input type="checkbox"/>	Coxreels	78
<input type="checkbox"/>	CUES, Inc.	41
<input type="checkbox"/>	Cyclops Electronics, Inc.	56
<input type="checkbox"/>	Doug Meadows Co. LLC	64
<input type="checkbox"/>	Draincables Direct	26
<input type="checkbox"/>	Duracable Manufacturing Co.	76
<input type="checkbox"/>	Dyna-Vac Equipment	68
<input type="checkbox"/>	Electric Eel Mfg.	115
<input type="checkbox"/>	Engines Inc.	50
<input type="checkbox"/>	Envirosight, LLC	5
<input type="checkbox"/>	EnviroSpec	107
<input type="checkbox"/>	ENZ USA, Inc.	34
<input type="checkbox"/>	Fluid Systems, Inc.	64
<input type="checkbox"/>	Flush Quip	42
<input type="checkbox"/>	ForBest Technologies Corp.	74

FREE Info.	ADVERTISER	PAGE
<input type="checkbox"/>	Fruitland Tool	76
<input type="checkbox"/>	FS Solutions	45
<input type="checkbox"/>	GapVax Incorporated	114
<input type="checkbox"/>	Gardner Denver Waterjetting	109
<input type="checkbox"/>	General Pipe Cleaners	2
<input type="checkbox"/>	Gorlitz Sewer & Drain, Inc.	37
<input type="checkbox"/>	Granite Leasing Co.	53
<input type="checkbox"/>	Guzzler Mfg. Inc.	11
<input type="checkbox"/>	Haaker Equipment Co.	30
<input type="checkbox"/>	Hackney Specialized Vehicles	18, 40
<input type="checkbox"/>	Hammelmanni Corp.	74
<input type="checkbox"/>	Hannay Reels	42
<input type="checkbox"/>	Hi-Vac Corporation	83
<input type="checkbox"/>	High Pressure Equipment Co.	28
<input type="checkbox"/>	Hotsy Cleaning Systems	19
<input type="checkbox"/>	Ingersoll-Rand Hibon	50
<input type="checkbox"/>	Insight Vision	67
<input type="checkbox"/>	Jack Doherty Supplies, Inc.	61
<input type="checkbox"/>	Jetstream of Houston	17
<input type="checkbox"/>	J.M. McKinney Co.	82
<input type="checkbox"/>	KEG Technologies Inc.	90
<input type="checkbox"/>	Ken's Truck & Equipment	107
<input type="checkbox"/>	Ken-Way Corp.	52
<input type="checkbox"/>	KMH Equipment, Inc.	72
<input type="checkbox"/>	KMT Aqua-Dyne, Inc.	34
<input type="checkbox"/>	Lansas Products Mfg.	52
<input type="checkbox"/>	LaPlace Equipment Company	60
<input type="checkbox"/>	Lenzyme Inc./Trap-Clear	4
<input type="checkbox"/>	Liberty Financial Group Inc.	88
<input type="checkbox"/>	Lindhorst Workhorse Nozzles	44
<input type="checkbox"/>	Link Manufacturing	84
<input type="checkbox"/>	Logiball Inc.	36
<input type="checkbox"/>	Masterliner Inc.	109
<input type="checkbox"/>	MAX-LIFE Mfg.	56

FREE Info.	ADVERTISER	PAGE
<input type="checkbox"/>	MaxLiner	71
<input type="checkbox"/>	Milwaukee Rubber Products	106
<input type="checkbox"/>	More USA East, Inc.	56
<input type="checkbox"/>	Mr. Rooter Corp.	57
<input type="checkbox"/>	MyTana Mfg. Company, Inc.	7
<input type="checkbox"/>	NESCO, LLC	108
<input type="checkbox"/>	NLB Corp.	51
<input type="checkbox"/>	Northcutt Co./Scooter Video	29
<input type="checkbox"/>	NozzTeq, Inc.	64
<input type="checkbox"/>	Nu Flow Technologies, Inc.	75
<input type="checkbox"/>	Pat's Pump & Blower	93
<input type="checkbox"/>	Pearpoint/Radiodetection	58
<input type="checkbox"/>	Perma-Liner Industries, Inc.	13
<input type="checkbox"/>	Petersen Products Co.	109
<input type="checkbox"/>	Pipe Genie Manufacturing	69
<input type="checkbox"/>	PipeLogix, Inc.	65
<input type="checkbox"/>	Piranha Hose Products	60
<input type="checkbox"/>	Pittsburgh Wire & Cable	112
<input type="checkbox"/>	Poly-Flow Mfg. LLC	36
<input type="checkbox"/>	PrimeLine Products, Inc.	82
<input type="checkbox"/>	Prototek Corp.	111
<input type="checkbox"/>	Pulsar 2000	27
<input type="checkbox"/>	Ratech Electronics Ltd.	55
<input type="checkbox"/>	Rausch Electronics USA, LLC	78
<input type="checkbox"/>	Real-Tite Plugs, Inc.	72
<input type="checkbox"/>	Relining Technologies, LLC	9
<input type="checkbox"/>	RIDGID	33, 43
<input type="checkbox"/>	Ritam Technologies, LP	91
<input type="checkbox"/>	RootX Root Control Corp.	7
<input type="checkbox"/>	RS Technical Services	44
<input type="checkbox"/>	Rush Sales	66
<input type="checkbox"/>	Safety Corporation of America	42
<input type="checkbox"/>	Sewer Equipment & Supplies	74
<input type="checkbox"/>	Sewerin USA LLC	22

FREE Info.	ADVERTISER	PAGE
<input type="checkbox"/>	Shamrock Pipe Tools, Inc.	28
<input type="checkbox"/>	Soil Surgeon	44
<input type="checkbox"/>	Spartan Tool, LLC	116
<input type="checkbox"/>	Spectrum Environmental	88
<input type="checkbox"/>	Speedway Drain Cleaning Prod.	77
<input type="checkbox"/>	SPIR STAR, Ltd.	25
<input type="checkbox"/>	SRECO-FLEXIBLE, Inc.	49
<input type="checkbox"/>	Stephen's Technologies	59
<input type="checkbox"/>	StoneAge, Inc.	26, 27
<input type="checkbox"/>	Super Products LLC	79
<input type="checkbox"/>	Superior Signal	10
<input type="checkbox"/>	T&T Tools, Inc.	4
<input type="checkbox"/>	Tornado Technologies	90
<input type="checkbox"/>	Triple R Specialty	50
<input type="checkbox"/>	TRY TEK Machine Works, Inc.	16
<input type="checkbox"/>	US Jetting, LLC	15
<input type="checkbox"/>	USB Sewer Equipment Corp.	106
<input type="checkbox"/>	Vac-Con, Inc.	3
<input type="checkbox"/>	Vactor Mfg.	23
<input type="checkbox"/>	Vacuum Truck Rentals	84
<input type="checkbox"/>	Vaporoooter	66
<input type="checkbox"/>	Vivax Corp.	60
<input type="checkbox"/>	Water Cannon Inc.	85
<input type="checkbox"/>	WaterJet Technology	78
<input type="checkbox"/>	Western Mule Cranes	52
<input type="checkbox"/>	Westmoor Ltd.	58
<input type="checkbox"/>	WinCan America, Inc.	12
<input type="checkbox"/>	WMI Inc.	14
<input type="checkbox"/>	Wolf Creek Co., Inc.	84
<input type="checkbox"/>	World-Tech Industries	63
<input type="checkbox"/>	Woma Corp	111

Cleaner

- 1 Year (12 issues) ... **\$15.50**
 - 2 Years (24 issues) ... **\$25.00**
 - 3 Years (36 issues) ... **\$35.00**
- (U.S. rates only. Call for intl. rates)

C3.09

Start/Renew my subscription to *Cleaner* magazine.

Send **FREE** information (No purchase necessary to receive FREE info.)
Please check advertiser boxes above and complete form below and at right.

Signature (required) _____ Date _____

Attention _____

Company Name _____

Mailing Address _____

City _____ State _____ Zip _____

Phone _____ Fax _____

E-Mail _____

METHOD OF PAYMENT (please check one):

- Check enclosed (payable to COLE Publishing Inc.)
- Charge to VISA _____ MasterCard _____ Discover _____
- Card # _____ V-Code _____
- Cardholder Name _____ Exp. Date _____

What is your company's primary function?

What else does your company do? (circle letters below):

- | | |
|--|--|
| A TV/Video Inspection | M Manufacturer of |
| B Pipeline Rehabilitation/Sewer Repair | N Septic System Design |
| C Drain/Sewer Cleaning (Rooting, Jetting) | P Plumbing/Heating/Cooling |
| D Dealer/Distributor of | Q Excavation/Grading |
| E Grease Pumping/Disposal/Treatment | R Refuse (Solid Waste) Hauler |
| F Septage or Sludge Disposal/Treatment | S Septic Tank Service-Pumping/Maintenance |
| G Government/Municipality/POTW | T Portable Toilet Rentals |
| H Hazardous/Industrial Liquid Waste Hauler | V Industrial Plant Service Vacuum/Cleaning |
| I Septic System Installation/Repair | W High Pressure Waterblasting |
| J Non-Hazardous Liquid Waste Hauler | Y Hydroexcavation |
| K Directional Drilling/Boring | Z Equipment Rental Center |
| L Consulting | Other _____ |

Fax this page (with payment option selected) to **715-546-3786**

Mail this page (with payment option selected) to
COLE Publishing, P.O. Box 220, Three Lakes, WI 54562

Phone **800-257-7222** Online at www.cleaner.com

www.gapvax.com



INDUSTRIAL VACUUM TRUCKS
WETVACS SKIDS
COMBINATION JETVAC TRUCKS
HYDRO-EXCAVATION TRUCKS
CYCLONE TRAILERS
STAND-ALONE BAGHOUSES
SOUND ENCLOSURES
PARTS &
ACCESSORIES



GapVax®

888-442-7829



PARTSEXPRESS

*The Perfect Fit
for all your parts and accessory needs*

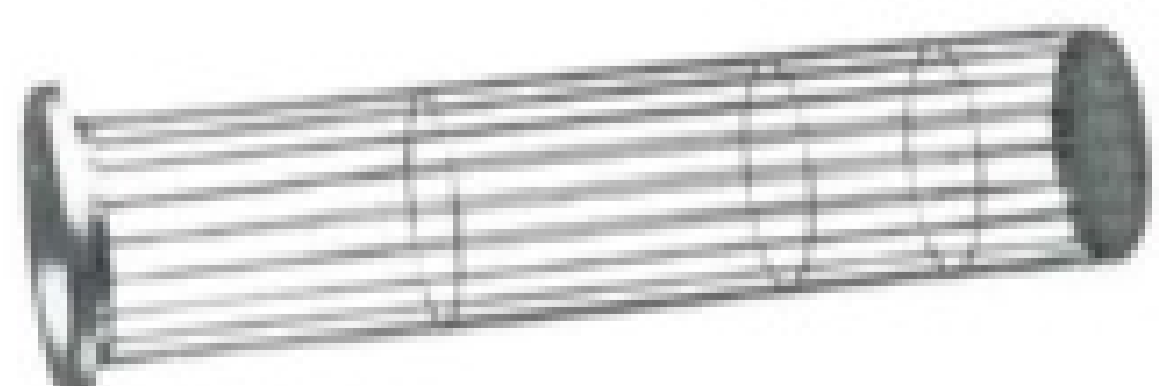
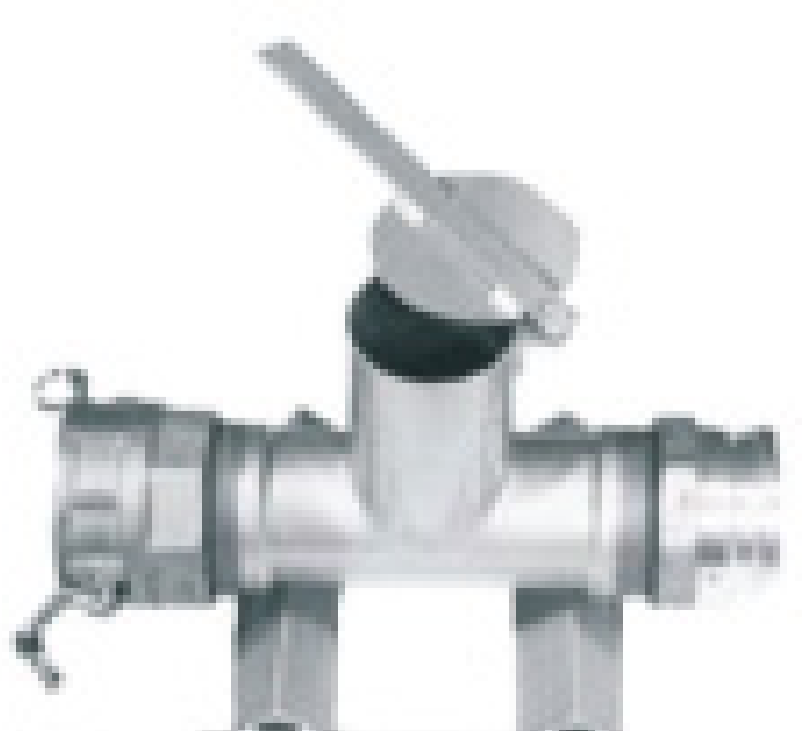
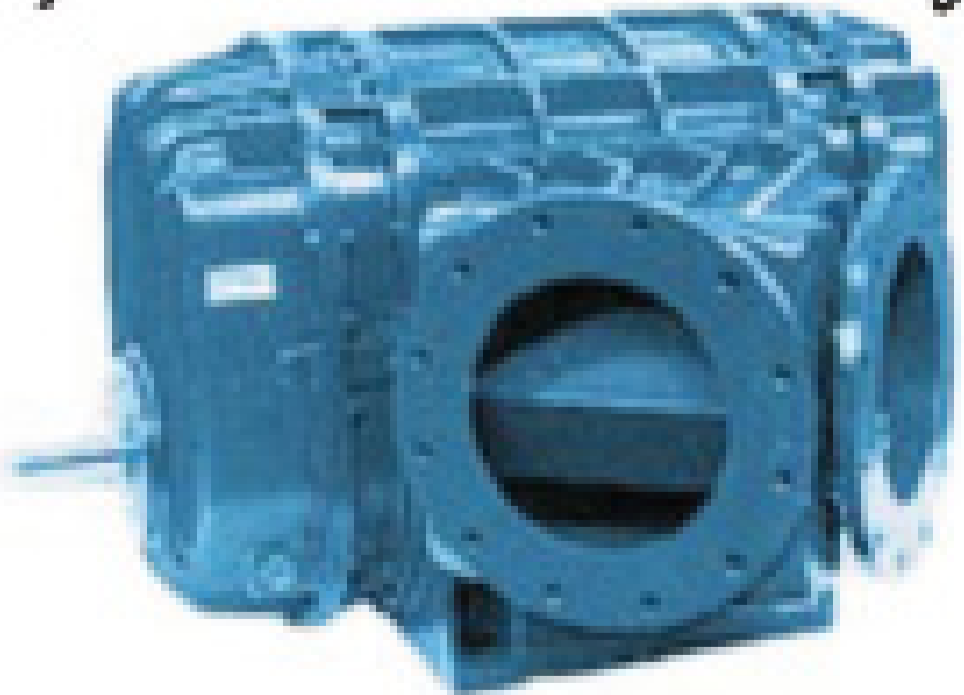
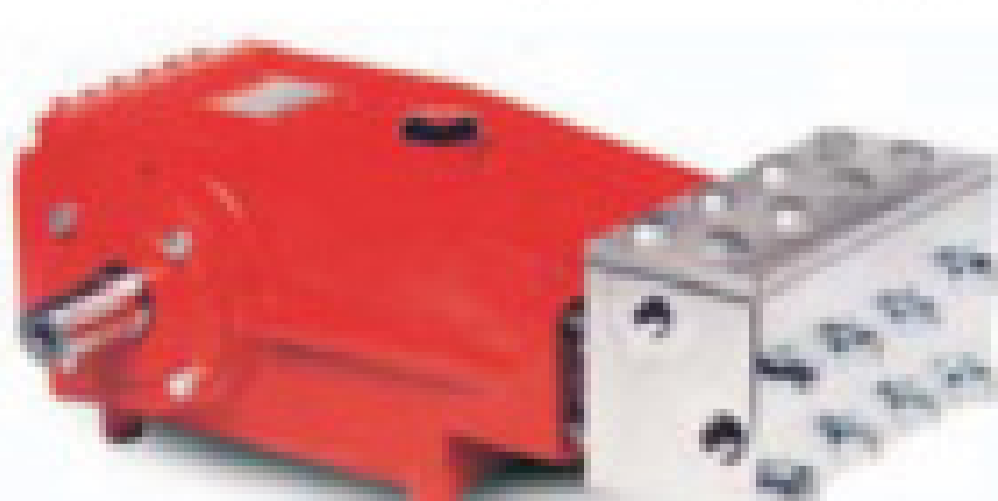

WANTED

3 SALES REPRESENTATIVES

GapVax® is looking for three highly motivated individuals to fill three different sales positions (one in the Southeast, West, and Midwest). We are a fast paced company, growing faster than any other company in our industry. If you are willing to work hard, travel, have good PR skills, and sales experience, you might be what we are looking for! Send your resume to betty@gapvax.com today!

NEW Model CT Drain Cleaner

MAXIMUM

Cable Control

UNIQUE Variable Speed Motor Feature gives the operator maximum cable control and exceptional cleaning power from 75 to 350 RPM with constant torque.

- The New Model CT Drain Cleaner is professionally engineered to clean 3/4" to 2-1/2" diameter drain lines up to 50 Ft.
- **Standard unit features a hand tighten Jacobs Chuck.** The CT is also available with a 2-way auto cable feed that keeps hands off rotating cable as it advances and retrieves cable with the push of a lever, and helps keep work area clean.
- Heavy-duty housing protects motor and internal wiring.
- Rugged stainless steel cable drum will not rust and resists denting.
- Well balanced, heavy-duty steel tubular frame allows for versatile two position operation.
- Built-in GFCI on 20 Ft. line cord protects operator from electrical shock.
- Air operated foot switch and cord assembly for ease of operation.
- Runs 1/4", 5/16" and 3/8" cable.



Patent Pending



The Counter-Top Drain Cleaner You Can Count On For Top Performance!

1-800-833-1212

Electric Eel[®]

Drain Cleaning Tools for Professionals www.electriceel.com

SPARTAN TALKS TOUGH.

Tom Griffin, New York
SPARTAN REP SINCE 1986



**“JUST SHOWS YOU, NOBODY DOES
SERVICE LIKE WE DO SERVICE.”**



SPARTAN
FOR TOUGH CUSTOMERS.
SINCE 1943

The president of the local state college called me not long ago. Now, as a college, they usually have work done for free by the state. But one day their Commons was completely backed up, it was four in the afternoon, and the guy they normally call was going home for the day. So I went out, sold them the jetter they needed and trained them how to use it so they could handle their own jobs in the future. Just shows you — for customers that work for a corporation or institution, nobody does service like we do service.